

FEATURES

- -55° to +125°C operation
- 16 to 50 VDC input
- Fully Isolated
- Optocoupler feedback
- Fixed switching frequency
600 kHz typical,
- Topology –
Dual Single Ended Flybacks
- 80 V / 120 ms transient protection
(12 Vout single and dual to 75 V,
15 Vout single and dual to 60V)
- Inhibit and sync functions
- Trim on single output models
- Up to 84% efficiency
- Low output noise

DC/DC CONVERTERS

28 VOLT INPUT

MHV SERIES

15 WATT

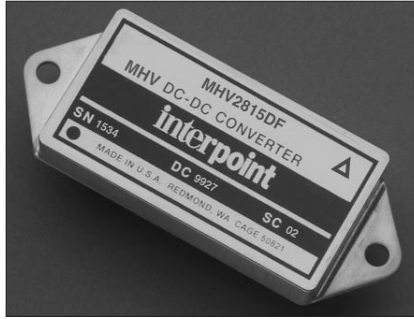

MODELS		
VDC OUTPUT		
SINGLE	DUAL	TRIPLE
3.3	±5	+5 & ±12
5	±12	+5 & ±15
12	±15	
15		

Size (max.): Non flanged Single and dual output models, case H2, 2.125 x 1.125 x 0.400 inches (53.98 x 28.58 x 10.16 mm)
Triple output models, case F1, 1.950 x 1.350 x 0.405 inches (49.53 x 34.29 x 10.29 mm)
Flanged Single and dual output models, case K3, 2.910 x 1.125 x 0.400 inches (73.91 x 28.58 x 10.16 mm)
Triple output models, case J1, 2.720 x 1.350 x 0.405 inches (69.09 x 34.29 x 10.29 mm)
See Section B8, cases H2, F1, K3, and J1 for dimensions.

Weight: 60 grams maximum.

Screening: Standard, ES, or 883 (Class H). See Section C2 for screening options, see Section A5 for ordering information.

DESCRIPTION

Interpoint's MHV Series™ of DC/DC converters offer a wide input voltage range of 16 to 50 VDC and a choice of nine different output voltage configurations comprised of single, dual or triple outputs. The converters will withstand transients of up to 80 V for up to 120 milliseconds while maintaining output voltages (with the exception of the 12 volt single and dual outputs which will withstand transients up to 75 volts and the 15 volt single and dual outputs which will withstand up to 60 volts). The MHV Series operates at a full 15 watts of output power (10 watts for the 3.3 volt single output) over the military temperature range of -55°C to +125°C while maintaining low input and output noise.

CONVERTER DESIGN

MHV Series DC/DC converters are switching regulators that use continuous flyback conversion topology with a clock frequency of approximately 600 kHz. MHV Series converters incorporate two internal converters with one converter phase shifted 180° from the other to create a dual phase/phase-shifted operation. Each of the internal converters operates at approximately one-half of the clock frequency. This proprietary technology eliminates cross regulation, minimizes input ripple, greatly reduces output ripple and improves efficiency. On the triple output models, this design provides completely independent regulation with no cross regulation effect between the main and auxiliary outputs and no minimum loading required on the main output.

INHIBIT FUNCTION

Open collector TTL levels control the inhibit circuit. The converter is enabled when the inhibit terminal is left unconnected or when the inhibit terminal is connected to a voltage between 11.5 and 50 V.

When a low (0.8 V) is applied to the inhibit terminal the converter shuts down, typically drawing 8.4 mA of input current. Inhibit terminal resistance is 3.3 k ohms and draws 8.4 mA, typical.

SYNCHRONIZATION FUNCTION

Applying an external signal of 40% to 60% duty cycle and 500 to 700 kHz will synchronize the converter to your system requirements. Free run clock frequency is approximately 600 kHz. If not used, the sync terminal must be left unconnected.

TRIM

Single output converters feature a trim range of as low as 80% to as high as 110% of Vout nominal, depending on the model. To trim up, connect a resistor from output common (pin 4) to the trim terminal (pin 3). To trim down, connect a resistor from the positive output (pin 5) to the trim terminal (pin 3). See Figure 4 and trim tables for more information.

UNDERVOLTAGE LOCKOUT

An undervoltage lockout of approximately 7 VDC keeps system current levels low during startup.

SHORT CIRCUIT PROTECTION

Under short circuit conditions of 130% or more of full load current, the converter will protect itself by shutting down. Short circuit duration should be brief because power dissipation may cause internal temperatures to rise rapidly. Restart is automatic upon removal of the short circuit.

MHV SERIES

15 WATT

DC/DC CONVERTERS

ABSOLUTE MAXIMUM RATINGS

- Input Voltage**
- 16 to 50 VDC
- Output Power**
- 15 watts (10 watts MHV283R3S)
- Lead Soldering Temperature (10 sec per lead)**
- 300°C
- Storage Temperature Range (Case)**
- -65°C to +150°C

RECOMMENDED OPERATING CONDITIONS

- Input Voltage Range**
- 16 to 50 VDC continuous
 - Transient: see Electrical Characteristics tables
- Case Operating Temperature (Tc)**
- -55°C to +125°C full power
 - -55°C to +130°C absolute
- Derating Output Power/Current**
- Linearly from 100% at 125°C to 0% at 130°C

SYNC AND INHIBIT

- Sync In (500 to 700 kHz)**
- Duty cycle 40% min, 60% max
 - Logic low 0.8 V max
 - Logic high 4.5 V min, 10 V max
 - Referenced to input common
 - If not used, leave unconnected
- Inhibit TTL Open Collector**
- Logic low (output disabled)
Logic low voltage ≤ 0.8 V
Inhibit pin current
8.4 mA typical, 10 mA maximum
 - Referenced to input common
 - Logic high (output enabled)
Open collector
Unconnected or 11.5 to 50 V

TYPICAL CHARACTERISTICS

- Output Voltage Temperature Coefficient**
- 100 ppm/°C typical
- Undervoltage Lockout**
- 7 V input typical
- Current Limit**
- 130% of full load typical at 25°C
- Isolation**
- 100 megohm minimum at 500 V
- Audio Rejection**
- 30 dB typical
- Conversion (Switching) Frequency**
- Free run mode 300 kHz typical
245 kHz. min, 355 kHz. max
- Clock Frequency**
- External sync range 500 to 700 kHz.
- Inhibit Pin Voltage (unit enabled)**
- 11 V typical

Electrical Characteristics: 25°C Tc, 28 VDC Vin, 100% load, free run, unless otherwise specified.

SINGLE OUTPUT MODELS		MHV283R3S			MHV2805S			MHV2812S			MHV2815S			UNITS
PARAMETER	CONDITIONS	MIN	TYP	MAX	MIN	TYP	MAX	MIN	TYP	MAX	MIN	TYP	MAX	
OUTPUT VOLTAGE		3.27	3.30	3.33	4.95	5.00	5.05	11.88	12.00	12.12	14.85	15.00	15.15	VDC
OUTPUT CURRENT	V _{IN} = 16 to 50 VDC	0	—	3.03	0	—	3.0	0	—	1.25	0	—	1.0	A
OUTPUT POWER	V _{IN} = 16 to 50 VDC	0	—	10	0	—	15	0	—	15	0	—	15	W
OUTPUT RIPPLE	10 kHz - 2 MHz													
VOLTAGE	Tc = -55°C to +125°C	—	5	60	—	10	60	—	7	60	—	5	60	mV p-p
LINE REGULATION	V _{IN} = 16 to 50 VDC	—	0	20	—	0	20	—	0	20	—	0	20	mV
LOAD REGULATION	NO LOAD TO FULL	—	15	45	—	15	40	—	5	35	—	5	40	mV
INPUT VOLTAGE	CONTINUOUS	16	28	50	16	28	50	16	28	50	16	28	50	VDC
NO LOAD TO FULL	TRANSIENT 120 ms	—	—	80	—	—	80	—	—	75	—	—	60	V
INPUT CURRENT	NO LOAD	—	23	45	—	29	52	—	26	51	—	28	57	mA
	FULL LOAD	—	489	518	—	687	724	—	638	678	—	638	687	mA
	INHIBITED	—	8.4	10	—	8.4	10	—	8.4	10	—	8.4	10	mA
INPUT RIPPLE CURRENT ¹	10 kHz - 20 MHz Tc = -55°C to +125°C	—	10	50	—	10	50	—	10	50	—	10	50	mA pp
EFFICIENCY		69	73	—	74	78	—	79	84	—	78	84	—	%
LOAD FAULT ²	POWER DISSIPATION SHORT CIRCUIT ²	—	—	9.5	—	—	11	—	—	11	—	—	10.5	W
	RECOVERY	—	—	20	—	—	20	—	—	20	—	—	20	ms
	OUTPUT CURRENT TRIP POINT	3.97	—	—	3.93	—	—	1.64	—	—	1.31	—	—	A
STEP LOAD RESPONSE ³	50% - 100% - 50%													
	TRANSIENT	—	—	250	—	—	300	—	—	300	—	—	350	mV pk
	RECOVERY	—	—	700	—	—	1500	—	—	900	—	—	700	μs
START-UP	DELAY	—	5	20	—	5	20	—	5	20	—	5	20	ms
0 TO 28 V _{IN}	OVERSHOOT	—	50	100	—	0	50	—	0	120	—	0	150	mV pk

Notes

1. Lin = 5.5 μH.
2. Load fault is a short circuit (<50 mΩ). Recovery is into a resistive load.
3. Load step transition ≥ 10 μs. Recovery = time to settle to within 1% of Vout final value.
4. Input step transition ≥ 10 μs. Recovery = time to settle to within 1% of Vout final value.

DC/DC CONVERTERS

MHV SERIES 15 WATT

Electrical Characteristics: 25°C Tc, 28 VDC Vin, 100% load, free run, unless otherwise specified.

DUAL OUTPUT MODELS		MHV2805D			MHV2812D			MHV2815D			UNITS
PARAMETER	CONDITIONS	MIN	TYP	MAX	MIN	TYP	MAX	MIN	TYP	MAX	
OUTPUT VOLTAGE	+V _{OUT}	4.95	5.00	5.05	11.88	12.00	12.12	14.85	15.00	15.15	VDC
	-V _{OUT}	4.95	5.00	5.05	11.88	12.00	12.12	14.85	15.00	15.15	
OUTPUT CURRENT	V _{IN} = 16 TO 50 VDC	—	—	±1.50	—	—	±0.625	—	—	±0.500	A
OUTPUT POWER ¹	V _{IN} = 16 TO 50 VDC	—	±7.5	15	—	±7.5	15	—	±7.5	15	W
OUTPUT RIPPLE VOLTAGE	10 kHz- 2 MHz Tc = -55°C to +125°C +V _{OUT} / -V _{OUT}	—	15	120	—	10	60	—	20	80	mVp-p
LINE REGULATION	V _{IN} = 16 TO 50 VDC ±V _{OUT}	—	0	20	—	0	20	—	0	20	mV
LOAD REGULATION	NO LOAD TO FULL ±V _{OUT}	—	5	40	—	5	40	—	5	40	mV
INPUT VOLTAGE	CONTINUOUS	16	28	50	16	28	50	16	28	50	VDC
NO LOAD TO FULL	TRANSIENT 120 msec	—	—	80	—	—	75	—	—	60	V
INPUT CURRENT	NO LOAD	—	18	25	—	30	40	—	35	45	mA
	FULL LOAD	—	670	705	—	634	670	—	635	670	
	INHIBITED	—	8.4	10	—	8.4	10	—	8.4	10	
INPUT RIPPLE CURRENT ²	10 kHz - 20 MHz Tc = -55°C to +125°C	—	10	200	—	10	200	—	10	200	mA p-p
EFFICIENCY		76	80	—	80	85	—	80	84	—	%
LOAD FAULT ³	POWER DISSIPATION										
	SHORT CIRCUIT	—	—	9	—	—	10	—	—	10	W
	RECOVERY	—	—	15	—	—	25	—	—	25	ms
	OUTPUT CURRENT TRIP POINT	1.97	—	—	0.819	—	—	0.655	—	—	A
STEP LOAD RESPONSE ⁴ ± V _{OUT}	50% – 100% — 50% TRANSIENT	—	—	200	—	—	300	—	—	400	mV pk
	RECOVERY	—	—	500	—	—	700	—	—	900	μs
	DELAY	—	5	12	—	10	18	—	12	20	ms
START-UP 0 TO 28 V _{IN}	OVERSHOOT	—	0	50	—	0	120	—	0	150	mV pk

Notes

- Up to 7.5 watts is available from either output.
- Lin = 2 μH.
- Load fault is a short circuit (<50 mΩ). Recovery is into a resistive load.
- Load step transition ≥ 10 μs. Recovery = time to settle to within 1% of Vout final value.
- Input step transition ≥ 10 μs. Recovery = time to settle to within 1% of Vout final value.

MHV SERIES

15 WATT

DC/DC CONVERTERS

Electrical Characteristics: 25°C Tc, 28 VDC Vin, 100% load, free run, unless otherwise specified.

TRIPLE OUTPUT MODELS		MHV28512T			MHV28515T			UNITS
PARAMETER	CONDITION	MIN	TYP	MAX	MIN	TYP	MAX	
OUTPUT VOLTAGE	MAIN	4.95	5.0	5.05	4.95	5.0	5.05	VDC
	+ AUXILIARY	11.88	12.0	12.12	14.85	15.0	15.15	
	- AUXILIARY	11.82	12.0	12.18	14.77	15.0	15.23	
OUTPUT CURRENT ¹ VIN = 16 TO 50	MAIN	0	—	2.0	0	—	2.0	A
	+ AUXILIARY	—	—	0.333	—	—	0.267	
	- AUXILIARY	—	—	0.333	—	—	0.267	
	TOTAL	—	—	2.416	—	—	2.333	
OUTPUT POWER ² VIN = 16 TO 50	MAIN	—	—	10	—	—	10	W
	+ AUXILIARY	—	—	4	—	—	4	
	- AUXILIARY	—	—	4	—	—	4	
	TOTAL	—	—	15	—	—	15	
OUTPUT RIPPLE VOLTAGE	10 kHz to 2 MHz MAIN	—	5	30	—	10	35	mV p-p
	10 kHz to 2 MHz ± AUXILIARY	—	5	30	—	10	35	
LINE REGULATION VIN = MIN. TO MAX.	MAIN	—	0	20	—	0	20	mV
	+AUXILIARY	—	1	35	—	5	35	
	- AUXILIARY	—	1	35	—	5	35	
LOAD REGULATION	MAIN	—	10	25	—	10	25	mV
	+AUXILIARY	—	10	45	—	15	55	
	- AUXILIARY	—	10	65	—	15	80	
CROSS REGULATION ³ - AUXILIARY	CONDITION A	—	300	500	—	300	500	mV
	CONDITION B	—	400	700	—	400	700	
INPUT VOLTAGE	CONTINUOUS	16	28	50	16	28	50	VDC
	TRANSIENT 120 ms	—	—	80	—	—	80	
INPUT CURRENT	NO LOAD	—	23	32	—	28	37	mA
	FULL LOAD	—	670	705	—	670	705	
	INHIBITED	—	8.4	10	—	8.4	10	
INPUT RIPPLE CURRENT	10 kHz to 10 MHz	—	10	40	—	15	40	mA p-p
EFFICIENCY		76	80	—	76	80	—	%
LOAD FAULT ⁴	SHORT CIRCUIT							W
	POWER DISSIPATION							
	MAIN	—	—	9	—	—	9	
	± AUXILIARY	—	—	8	—	—	8	
STEP LOAD RESPONSE ^{5, 6}	TRANSIENT							mV
	MAIN	—	—	250	—	—	250	
	± AUXILIARY	—	—	500	—	—	500	
	RECOVERY							ms
	MAIN	—	—	2.5	—	—	2.5	
	± AUXILIARY	—	—	4	—	—	3.5	
START-UP ⁶ 0 TO 28 VIN	DELAY EACH OUTPUT	—	5	12	—	5	12	ms

Notes

- The sum of the 12 volt auxiliary output currents may not exceed 416 mA. The sum of the 15 volt auxiliary output currents may not exceed 333 mA.
- The sum of the auxiliary output power may not exceed 5 watts.
- Cross regulation occurs between the two auxiliaries and is measured on -aux. +5 is held constant at 2.0 A. Cross regulation is specified for two conditions:
 - Positive aux. = 2.5 W; negative aux. = 2.5 W to 0.5 W.
 - Negative aux. = 4 W to 1 W; positive aux. = 1 W to 4 W, simultaneous.
- Load fault is a short circuit (<50 mΩ). Recovery is into a resistive load.
- Load step transition ≥ 10 μs. Recovery = time to settle to within 1% of Vout final value.
- Input step transition ≥ 10 μs. Recovery = time to settle to within 1% of Vout final value.
- Lin = 5.5 μH.

DIAGRAMS

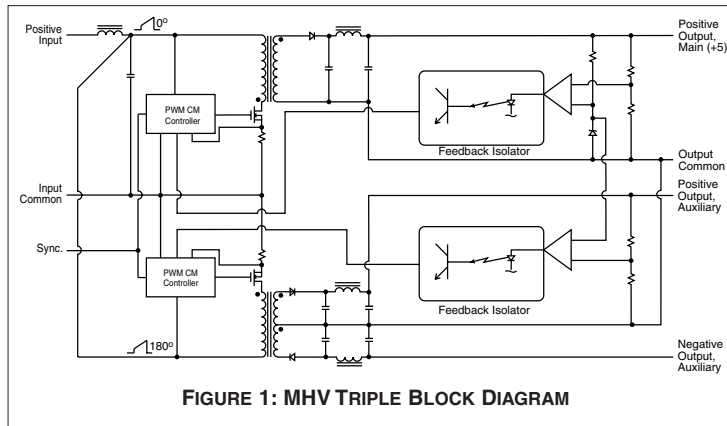

FIGURE 1: MHV TRIPLE BLOCK DIAGRAM

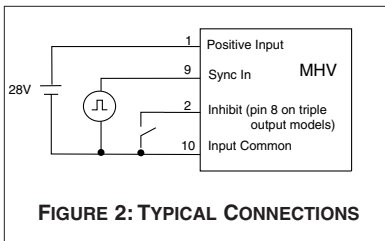

FIGURE 2: TYPICAL CONNECTIONS

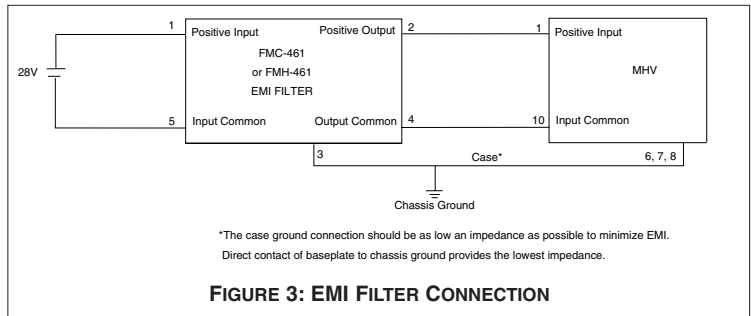

FIGURE 3: EMI FILTER CONNECTION

TRIM – SINGLE OUTPUT MODELS ONLY

Calculated Trim

$$\text{Trim down: } R_T (\text{k}\Omega) = \left(\frac{V_o - 2.5}{V_o \text{ nominal} - V_o} \right) A - B$$

$$\text{Trim up: } R_T (\text{k}\Omega) = \left(\frac{2.5A}{V_o - V_o \text{ nominal}} \right) - B$$

V_o = desired output voltage

Formula Values by Model

	3.3V	5V	12V	15V
A	3.7	3.7	14	18.2
B	10	10	30	30

Quick Reference Trim Table

MODEL	% V_{OUT} NOMINAL					
	110	106	102	95	90	80
	R_{TRIM} (R_T) k ohms					
MHV283R3S	18	36	128	4	n/a	n/a
MHV2805S	8	20	81	23	5	n/a
MHV2812S	n/a	19	116	177	67	11
MHV2815S	0.3	21	122	255	104	28

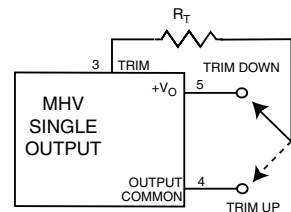

FIGURE 4: MHV SINGLE OUTPUT TRIM

Notes

If calculated result is a negative value, the desired output voltage is outside the allowed trim range.

Calculated values of R_T are $\pm 15\%$.

When trimming up, do not exceed the maximum output power.

When trimming down, do not exceed the maximum output current.

MHV SERIES 15 WATT

DC/DC CONVERTERS

PIN OUT

Pin	Single Output	Dual Output	Triple Output
1	Positive Input	Positive Input	Positive Input
2	Inhibit	Inhibit	Main (+5) Output
3	Trim	Positive Output	Output Common
4	Output Common	Output Common	Neg. Aux. Output
5	Positive Output	Negative Output	Pos. Aux. Output
6,7	Case Ground	Case Ground	Case Ground
8	Case Ground	Case Ground	Inhibit
9	Sync In	Sync In	Sync In
10	Input Common	Input Common	Input Common

Leave sync pin (pin 9) unconnected if not used.

Dot on top of cover indicates pin one.

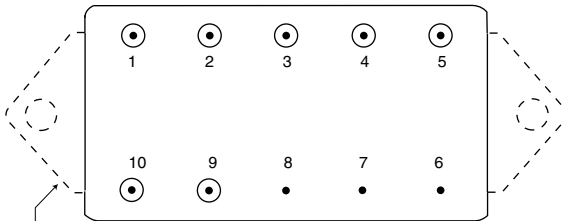

Dotted line outlines flanged package option.

See Section B8, cases H2 and K3 for dimensions.

FIGURE 5: PIN OUT SINGLES AND DUALS

Dot on top of cover indicates pin one.

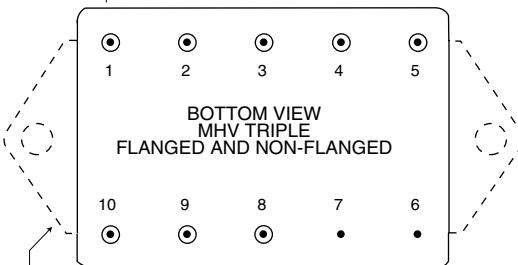

Dotted line outlines flanged package option.

See Section B8, cases F1, J1, and J2 for dimensions.

FIGURE 6: PIN OUT TRIPLE

SMD NUMBERS

STANDARD MICROCIRCUIT DRAWING (SMD)	MHV SERIES SIMILAR PART
IN PROCESS	MHV283R3S/883
	MHV2805S/883
	MHV2812S/883
	MHV2815S/883
	MHV2805D/883
	MHV2812D/883
	MHV2815D/883
	MHV28512T/883
MHV28515T/883	

Flanged SMD numbers for the MHV Series of converters have the suffix HZC instead of HXC. For exact specifications for an SMD product, refer to the SMD drawing. Call your Interpoint representative for status on MHV SMD releases. See Section A3, SMDs, for more information.

MODEL NUMBERING KEY

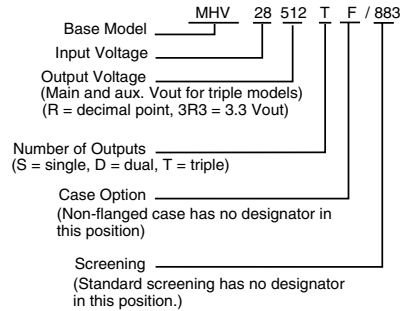

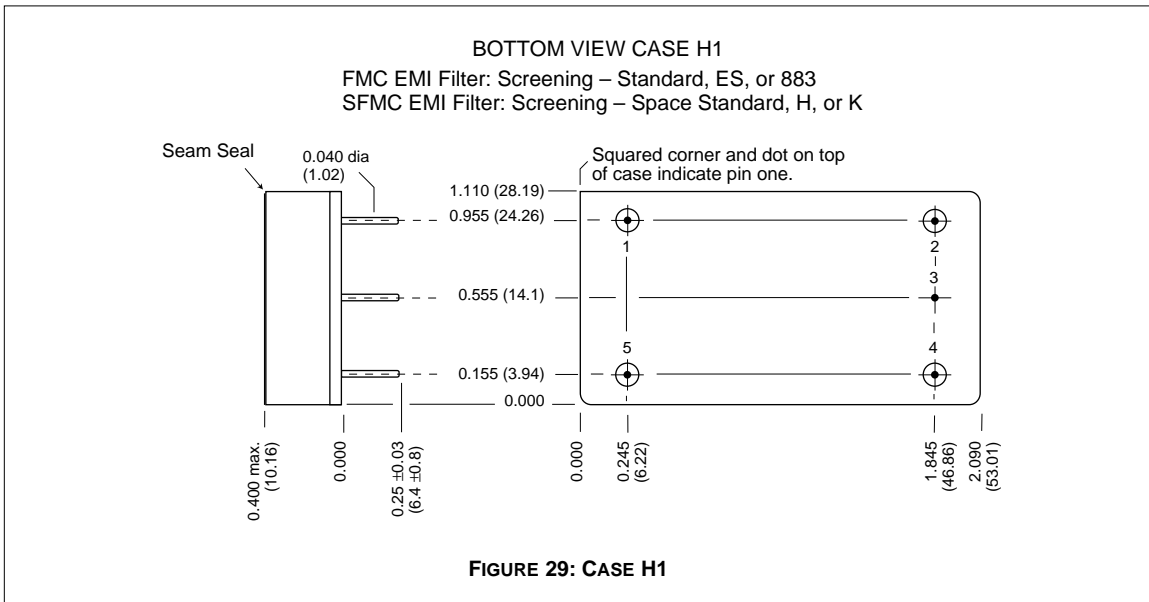
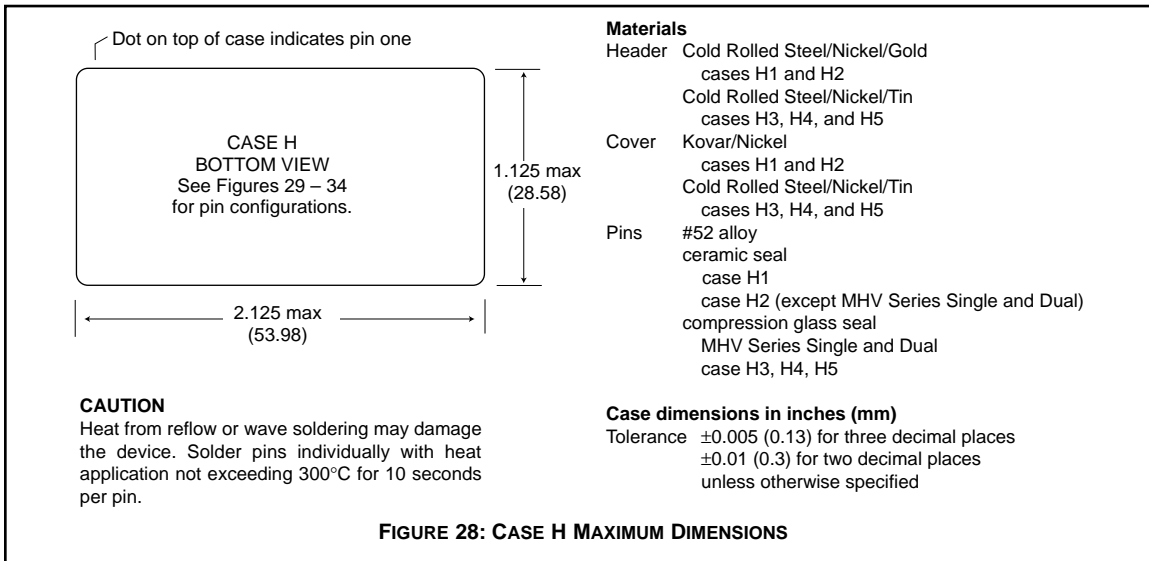

Note: Although every effort has been made to render the case drawings at actual size, variations in the printing process may cause some distortion. Please refer to the numerical dimensions for accuracy.

CASE H

CASES

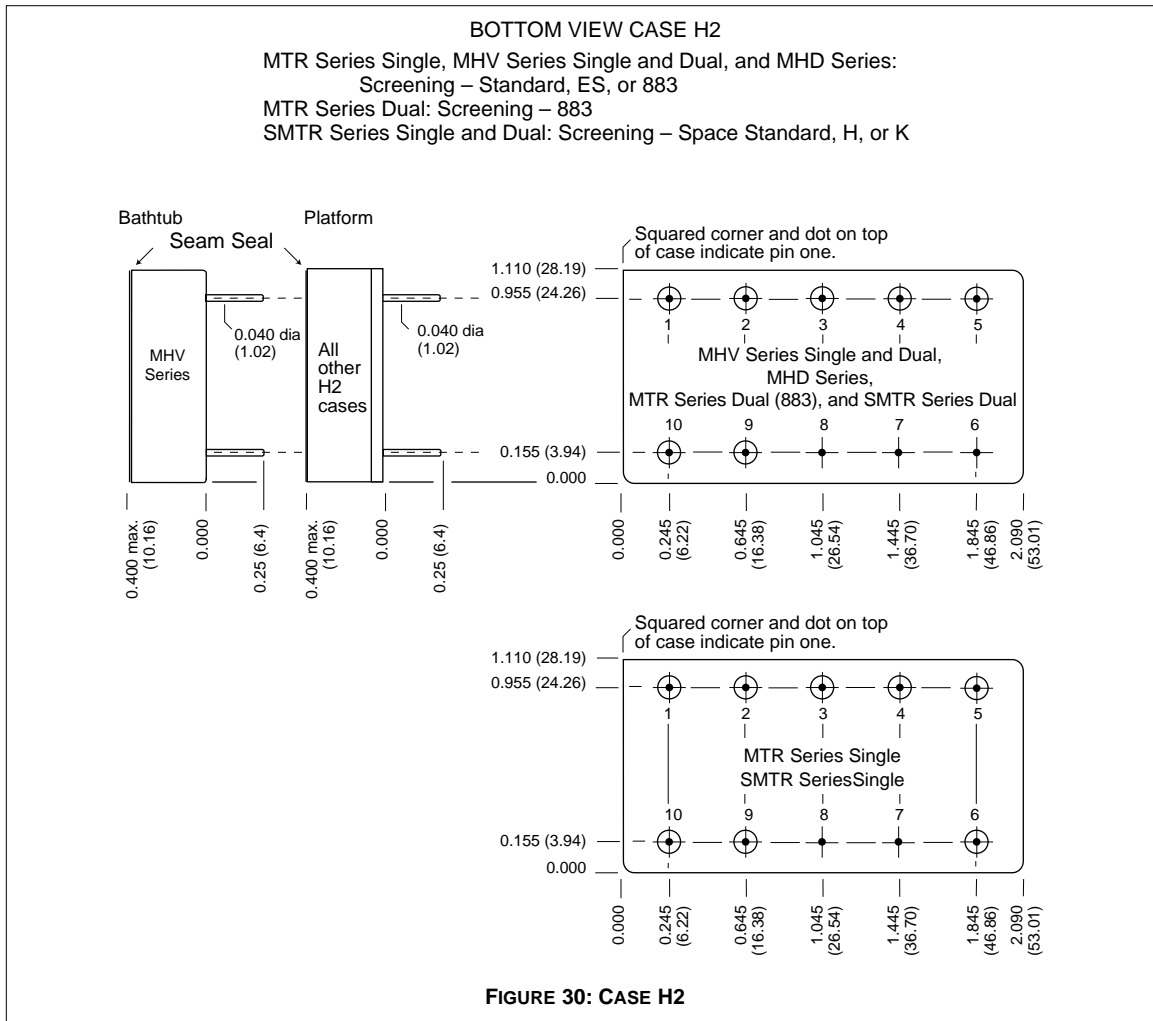
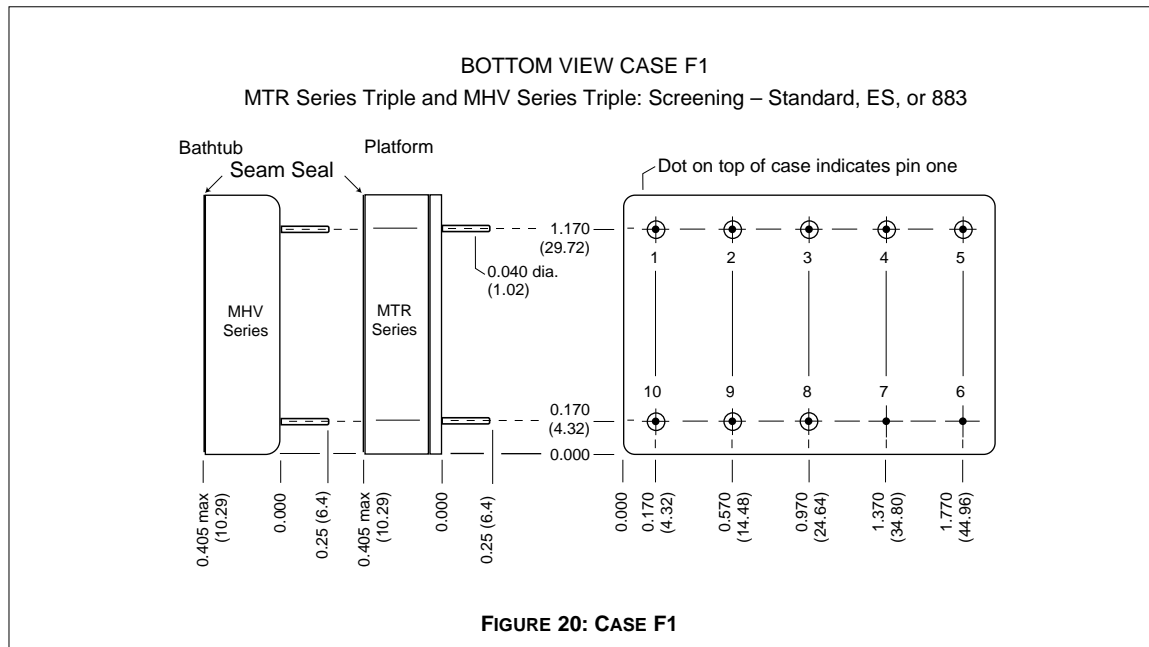
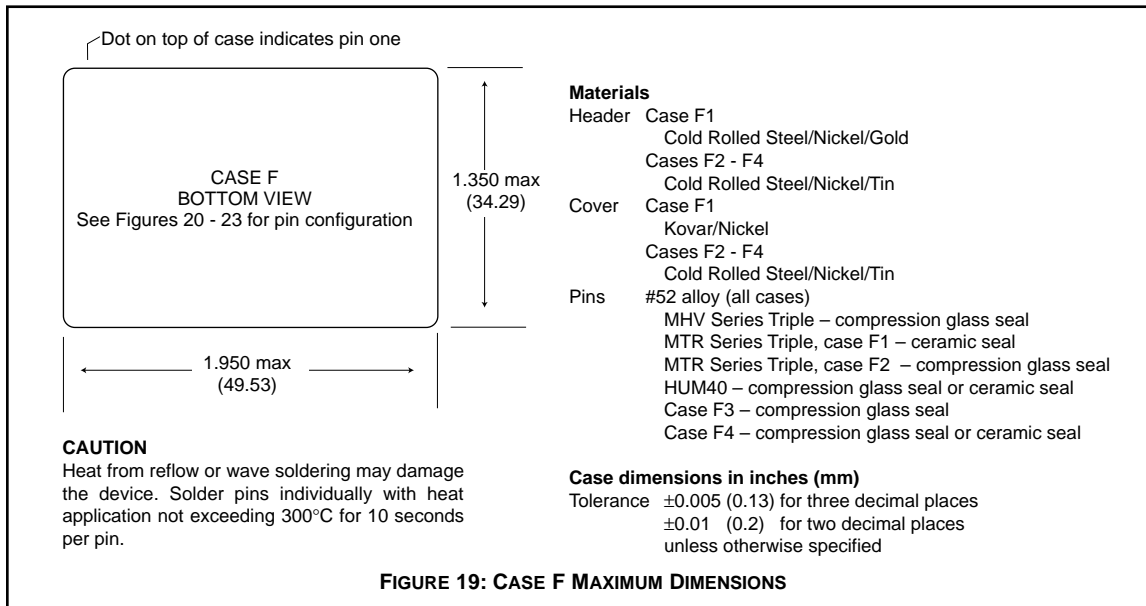

FIGURE 30: CASE H2

CASE F

CASES



Note: Although every effort has been made to render the case drawings at actual size, variations in the printing process may cause some distortion. Please refer to the numerical dimensions for accuracy.

CASE K

CASES

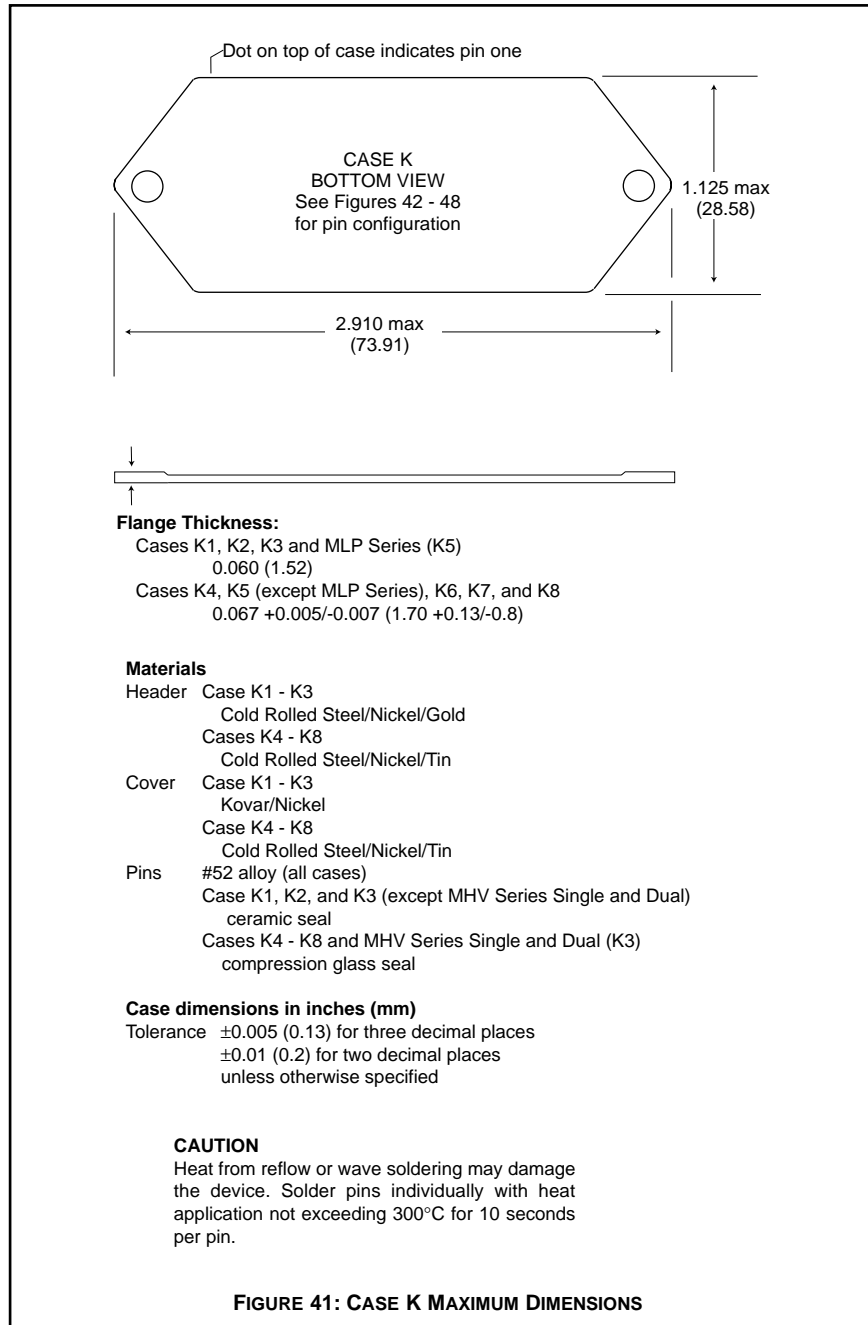

BOTTOM VIEW CASE K3

Flanged cases: Designator required in Case Option position of model number.
 MTR Series Single, MHV Series Single and Dual, MHD Series:
 Screening – Standard, ES, or 883
 MTR Series Dual: Screening – 883
 SMTR Series: Screening – Space Standard, H, or K

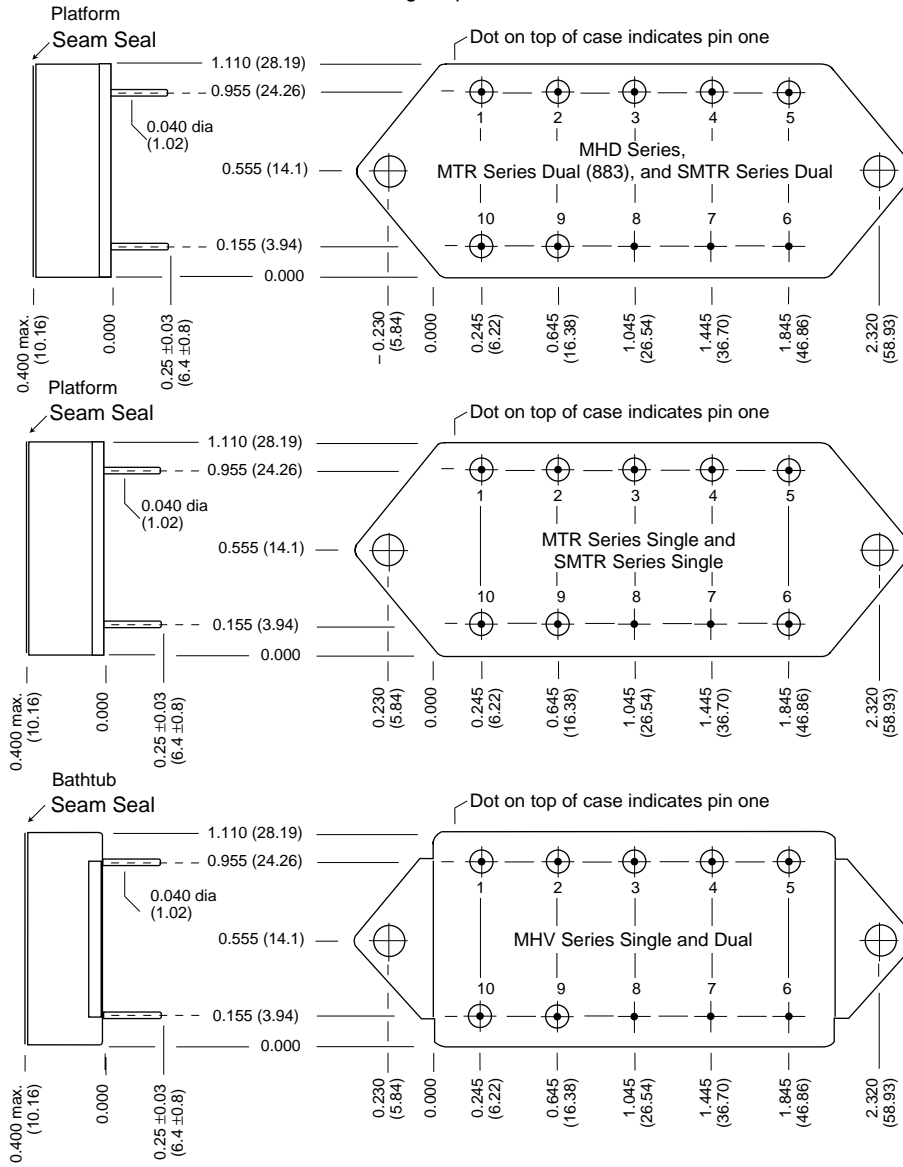
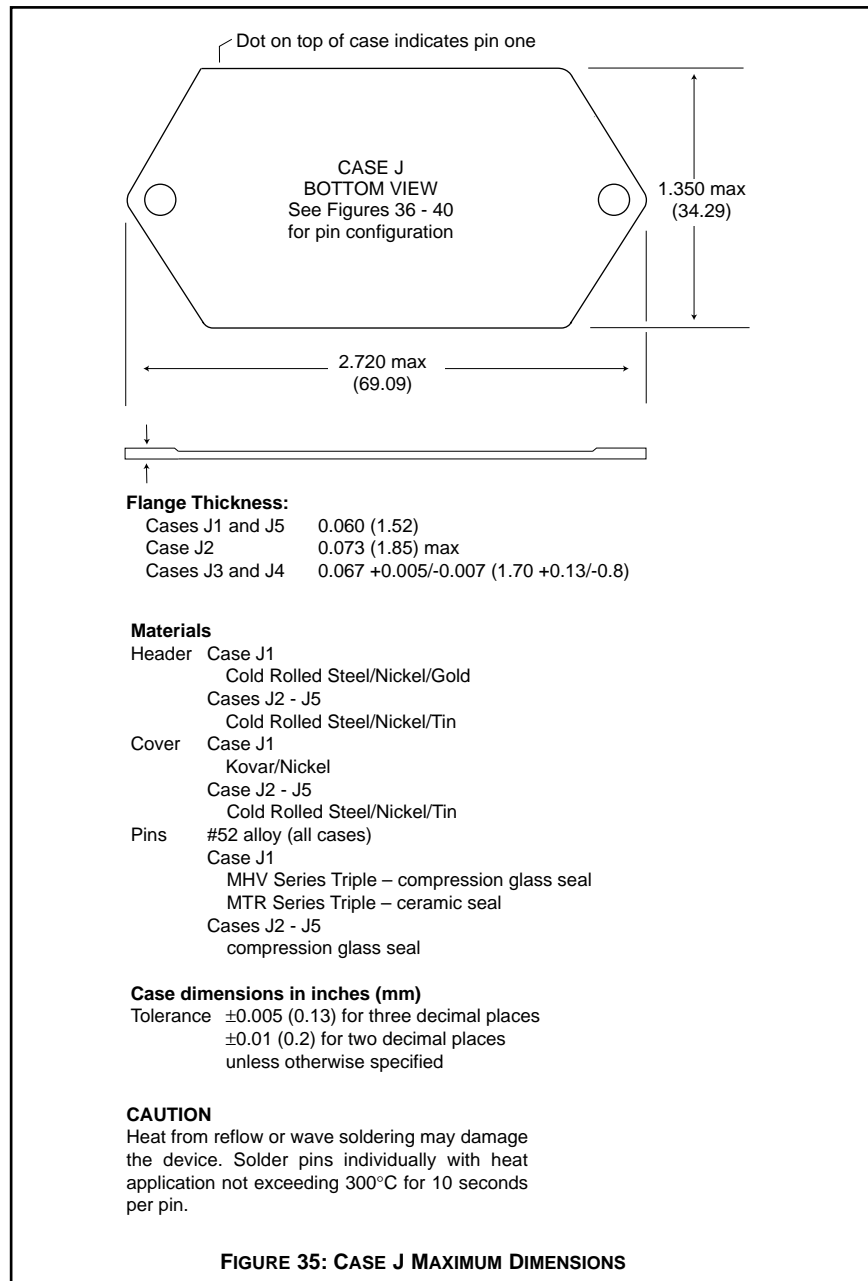

FIGURE 44: CASE K3

CASE J

CASES



Note: Although every effort has been made to render the case drawings at actual size, variations in the printing process may cause some distortion. Please refer to the numerical dimensions for accuracy.

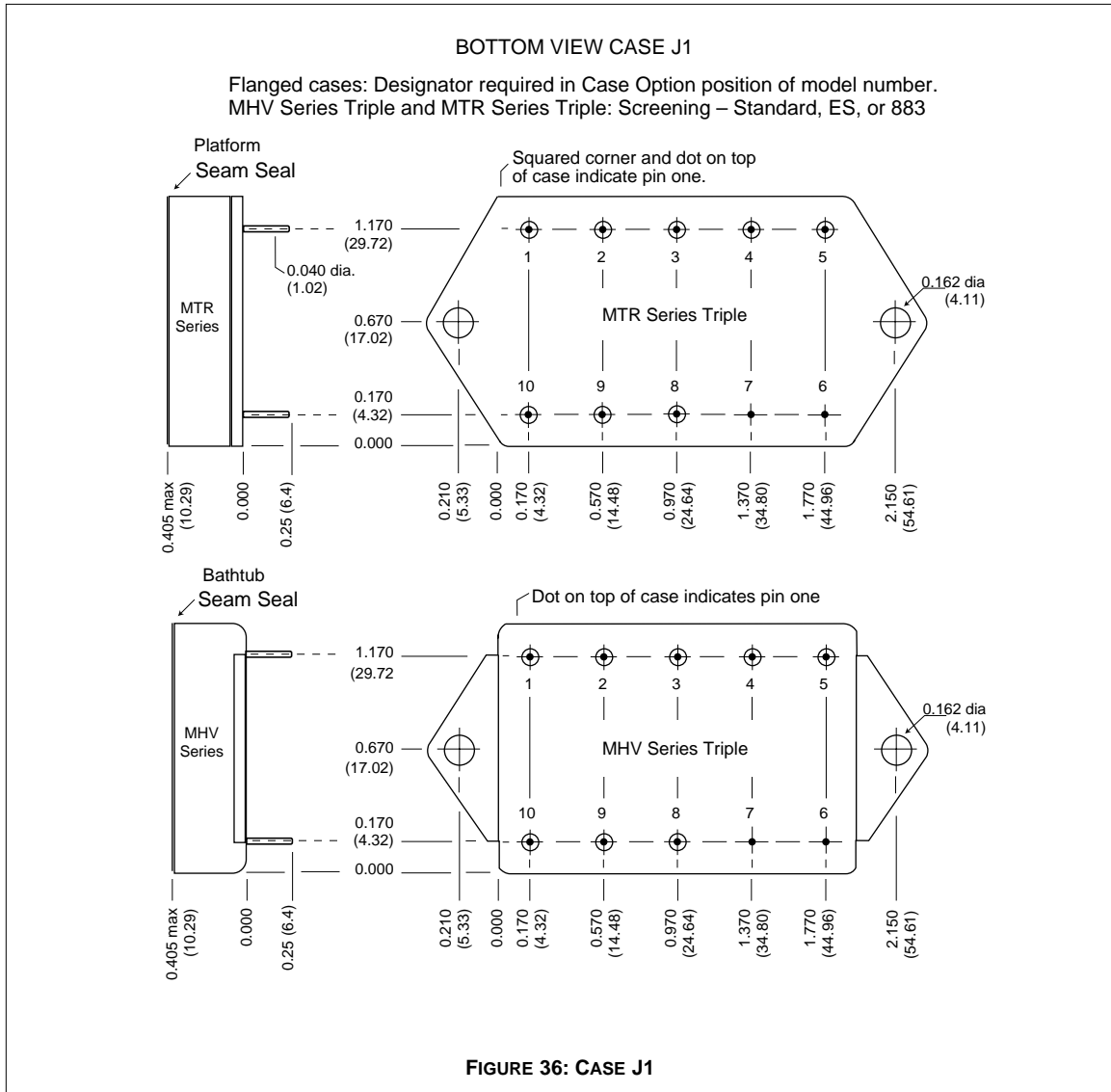

QA SCREENING 125°C PRODUCTS

125°C PRODUCTS

TEST (125°C Products)	STANDARD	/ES	/883 (Class H)*
PRE-CAP INSPECTION Method 2017, 2032	yes	yes	yes
TEMPERATURE CYCLE (10 times) Method 1010, Cond. C, -65°C to 150°C Method 1010, Cond. B, -55°C to 125°C	no no	no yes	yes no
CONSTANT ACCELERATION Method 2001, 3000 g Method 2001, 500 g	no no	no yes	yes no
BURN-IN Method 1015, 160 hours at 125°C 96 hours at 125°C case (typical)	no no	no yes	yes no
FINAL ELECTRICAL TEST MIL-PRF-38534, Group A Subgroups 1 through 6: -55°C, +25°C, +125°C Subgroups 1 and 4: +25°C case	no yes	no yes	yes no
HERMETICITY TESTING Fine Leak, Method 1014, Cond. A Gross Leak, Method 1014, Cond. C Gross Leak, Dip (1 x 10 ⁻³)	no no yes	yes yes no	yes yes no
FINAL VISUAL INSPECTION Method 2009	yes	yes	yes

Test methods are referenced to MIL-STD-883 as determined by MIL-PRF-38534.

*883 products are built with element evaluated components and are 100% tested and guaranteed over the full military temperature range of -55°C to +125°C.

Applies to the following products

MOR Series	MHD Series	MGH Series	FMGA EMI Filter
MFLHP Series	MHV Series	MCH Series	FMSA EMI Filter
MFL Series	MHF+ Series	FM-704A EMI Filter	HUM Modules**
MHP Series	MHF Series**	FMD**/FME EMI Filter	LCM Modules**
MTR Series	MGA Series	FMC EMI Filter	LIM Modules
MQO Series**	MSA Series	FMH EMI Filter	

**MFLHP Series, MQO Series, MHF Series, FMD EMI Filters, Hum Modules, and LCM Modules do not offer '883' screening.