



500 mW DC/DC Converter

EPC1193G-X



- Unregulated DC/DC Converter
- Input/Output Isolation : 1500 Vrms
- Very High Efficiency : 80%-85% Typ.
- Operating Temperature : 0°C to +70°C
- UL1446 Class B Insulating System
- UL94V-0 Recognized Materials

Electrical Specifications

PCA Part Numbers	V In Volts (± 10%)	V Out Volts	I Out (mA Max.)	Ripple & Noise (mV p-p)		Input Ripple Current (mA p-p)		Efficiency (% Typ.) @ Full Load	Input/Output Isolation (Vrms)
				Typ.	Max.	Typ.	Max.		
EPC1193G-1	5.0	5.0	100	18.0	25.0	8.5	15.0	80	1500
EPC1193G-2	5.0	6.5	77	16.5	25.0	8.5	15.0	83	1500
EPC1193G-3	5.0	9.0	56	16.0	25.0	8.0	15.0	85	1500
EPC1193G-4	5.0	12.0	42	15.5	25.0	8.0	15.0	85	1500
EPC1193G-5	5.0	15.0	34	12.0	25.0	9.5	15.0	84	1500
EPC1193G-6	5.0	24.0	21	12.0	25.0	11.0	20.0	82	1500

Notes :

1. Voltage Accuracy : -3% Typ. @ Maximum Load
2. Input Filter : Capacitor
3. Line Voltage Regulation : 1%/ (Output Voltage Change Percentage/Input Voltage Change Percentage)
4. Load Voltage Regulation (10% to 100% Full Load) : +15% Max., -5% Max. for 5.0 V, 6.5 V, +12% Max., -5% Max. for 9.0 V, 12 V, 15 V, 24 V Out
5. Short Circuit Duration : 1 Second
6. Output Ripple Filtering : Simple 33 KHz L/C Filter can be added to reduce Output Ripple & Noise to 2 mV p-p
7. Minimum Load Requirement : 10%
8. Absolute Maximum Rating : V In = 7.0 Volt Max.
9. Input Current @ 0% Load : 2.5 mA Typ.
10. Load Voltage Regulation @ 0% Load : +25% Max. for 5.0 V, 6.5 V, 9.0 V, 12 V Out +20% Max. for 15 V, 24 V Out

Package

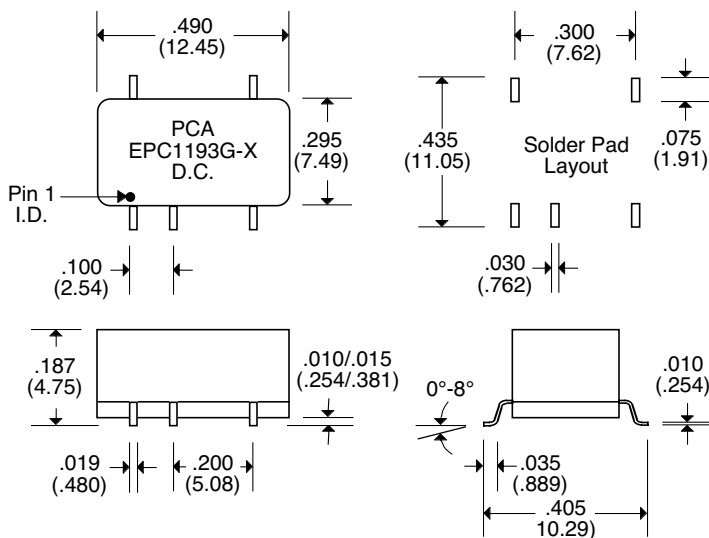

Pin Connections

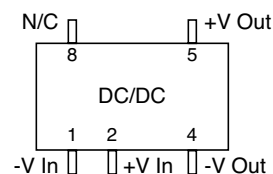

Unless Otherwise Specified Dimensions are in Inches /mm ±.010 /.25