



STA2056 PALINURO

REAL ONE CHIP SOLUTION FOR BOTH AUTONOMOUS AND HOST BASED GPS APPLICATION

DATA BRIEF

1 MAIN FEATURES

1.1 RF SECTION

- Complete RF for active antenna system
- Easily interfaced to passive antenna
- On-chip low phase noise VCO/PLL
- On-chip integrated loop filter and IF filter
- Integrated Wide Dynamic Range Mixer
- Few external components required
- Voltage supply operation 1.8V typical
- Low power consumption (~15mA)

1.2 BASEBAND SECTION

- ARM7TDMI[®]Core (up to 64MHz)
- STC8 12 channels correlator
- 256KB ROM
- 64KB RAM (4K backup)
- 3.3V for I/O
- Internal 1.8V core supply
- Low power consumption (~20mA@16MHz)

1.3 PERIPHERALS SECTION

- 4 channel sigma delta A/D
- 2 x UARTs 4 x timers RTC
- GPIO pins multiplexed with alternate functions
- I²C
- SPI
- CAN 2.0 B active
- External Memory Interface
(in TQFP176 package, development only)

1.4 Operating Temperature

- -40°C +85°C

Figure 1. Package

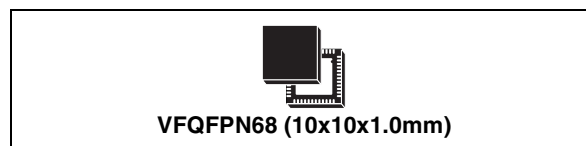

Table 1. Order Codes

Part Number	Package
STA2056V	VFQFPN68

1.5 Package

- VFQFPN68 10mm x 10mm

1.6 GPS LIBRARY

- GPS code available in ROM for full GPS functions and related peripherals.
- Possible ROM customization for dedicated applications (i.e. CAN based)

1.7 EVALUATION/DEVELOPMENT KIT

- Evaluation kit for GPS performance test.
- Standard library available with basic commands to enable specific functions (GPIO, A/D converter)
- Development kit for software customization with STA2056 with EMI option (STA2056B)

2 DESCRIPTION

STA2056 is one chip GPS featuring the complete RF for active antenna systems and baseband functionality in a QFN 68pin package. STA2056 System-on-Chip combines GPS performances with low power consumption. Thanks to the few external components STA2056 makes the application simple and smaller.

Figure 2. Block Diagram

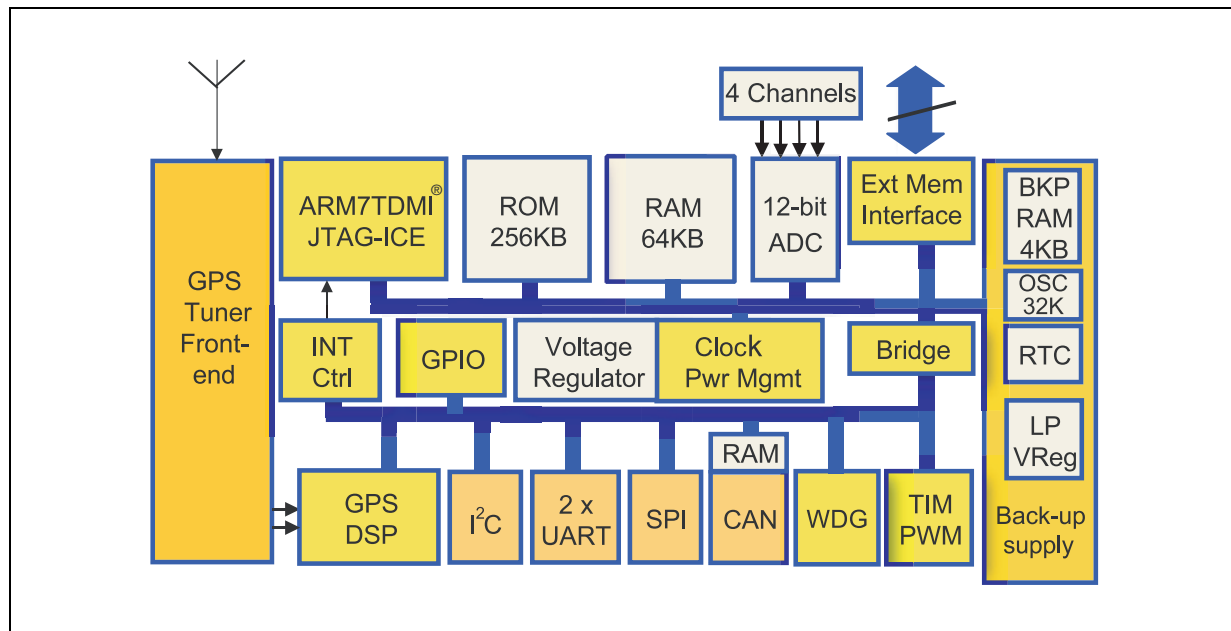

Table 2. Revision History

Date	Revision	Description of Changes
September 2004	1	First Issue
January 2005	2	Modified the Operating Temperature range on the page 1.

Information furnished is believed to be accurate and reliable. However, STMicroelectronics assumes no responsibility for the consequences of use of such information nor for any infringement of patents or other rights of third parties which may result from its use. No license is granted by implication or otherwise under any patent or patent rights of STMicroelectronics. Specifications mentioned in this publication are subject to change without notice. This publication supersedes and replaces all information previously supplied. STMicroelectronics products are not authorized for use as critical components in life support devices or systems without express written approval of STMicroelectronics.

The ST logo is a registered trademark of STMicroelectronics.
All other names are the property of their respective owners

© 2005 STMicroelectronics - All rights reserved

STMicroelectronics group of companies

Australia - Belgium - Brazil - Canada - China - Czech Republic - Finland - France - Germany - Hong Kong - India - Israel - Italy - Japan -
Malaysia - Malta - Morocco - Singapore - Spain - Sweden - Switzerland - United Kingdom - United States of America

www.st.com