

STRUCTURE	Silicon Monolithic Integrated Circuit
PRODUCT NAME	1ch DC / DC Converter with synchronous rectifier
TYPE	<b>BD9142MUV</b>
FEATURES	<ul style="list-style-type: none"> <li>• Output Voltage : 1.0~3.3V / Adjustable</li> <li>• Output Current : 3A</li> <li>• High Efficiency and Fast Transient Response</li> <li>• Dynamic Input Switching</li> </ul>

## ○ABSOLUTE MAXIMUM RATING (Ta=25°C)

Parameter	Symbol	Limit	Unit
Supply Voltage	QVCC	-0.3~+7 * <sup>1</sup>	V
	PVCC		
	AVCC		
BST Voltage	VBST	-0.3~+14	V
BST-SW Voltage	VBST-SW	-0.3~+7	V
EN, SW, ITH, DET VREG, CTL, ADJ Voltage	VEN, VSW, VITH, VDET VVREG, VCTL, VADJ	-0.3~+7	V
Power Dissipation	Pd1	0.34 * <sup>2</sup>	W
	Pd2	0.69 * <sup>3</sup>	W
	Pd3	2.20 * <sup>4</sup>	W
	Pd4	3.56 * <sup>5</sup>	W
Operating Temperature Range	Topr	-40~+85	°C
Storage Temperature Range	Tstg	-55~+150	°C
Maximum Junction Temperature	Tjmax	+150	°C

\*<sup>1</sup> Pd and Tj=150°C should not be exceeded.

\*<sup>2</sup> IC only.

\*<sup>3</sup> 1 layer, mounted on a board 74.2mm×74.2mm×1.6mm Glass-epoxy PCB (Copper foil area : 10.29mm<sup>2</sup>)

\*<sup>4</sup> 4 layers, mounted on a board 74.2mm×74.2mm×1.6mm Glass-epoxy PCB  
(Copper foil area : 10.29mm<sup>2</sup>), copper foil in each layers.

\*<sup>5</sup> 4 layers, mounted on a board 74.2mm×74.2mm×1.6mm Glass-epoxy PCB  
(Copper foil area : 5505mm<sup>2</sup>), copper foil in each layers.

## ○OPERATING CONDITIONS (Ta=-40~+85°C)

Parameter	Symbol	Min.	Typ.	Max.	Unit
Supply Voltage	QVCC	4.5	5.0	6.5	V
	PVCC				
	AVCC				
EN Voltage	VEN	0	-	QVCC	V
Output Voltage range	VOUT	1.0	-	3.3	V
SW Average Output Current1 (PVCC INPUT)	ISW1	-	-	3.0* <sup>6</sup>	A
SW Average Output Current2 (QVCC INPUT)	ISW2	-	-	0.1	A

\*<sup>6</sup> Pd should not be exceeded.

○ELECTRICAL CHARACTERISTICS

(Unless otherwise specified , Ta=25°C, QVcc =5V, EN= QVcc)

Parameter	Symbol	Limit			Unit	Condition
		Min.	Typ.	Max.		
Standby Current	ISTB	-	0	10	uA	EN=0
Bias Current	ICC	-	400	600	uA	
EN Low Voltage	VENL	-	GND	0.8	V	Standby
EN High Voltage	VENH	2.0	Vcc	-	V	Active
EN Input Current	IEN	-	10	20	uA	VEN=5V
Oscillation Frequency	FOSC	0.8	1	1.2	MHz	
INPUT FET ON Resistance	RONI	-	4.5	7.2	Ω	
Highside FET ON Resistance	RONH	-	130	210	mΩ	
Lowside FET ON Resistance	RONL	-	130	210	mΩ	
ADJ Reference Voltage	VADJ	0.788	0.800	0.812	V	
ITH SINK Current	ITHSI	10	20	-	uA	VADJ=1V
ITH Source Current	ITHSO	10	20	-	uA	VADJ=0.6V
UVLO Threshold Voltage	VUVLO1	3.8	4.0	4.2	V	QVCC=5→0V
UVLO Release Voltage	VUVLO2	3.85	4.1	4.4	V	QVCC=0→5V
DET Threshold Voltage	VDETRST	0.78	0.8	0.82	V	
DET Release Voltage	VDETST	0.785	0.81	0.84	V	
CTL Pch ON Resistance	RONPCTL	-	110	165	Ω	PVcc=5V, Id=1mA
CTL Nch ON Resistance	RONNCTL	-	110	165	Ω	PVcc=5V, Id=1mA
Soft Start Time	TSS	0.5	1	2	ms	
Timer Latch Time	TLATCH	0.5	1	2	ms	
Output Short circuit Threshold Voltage	VSCP	-	0.40	0.56	V	VADJ=0.8→0V

○PHYSICAL DIMENSION

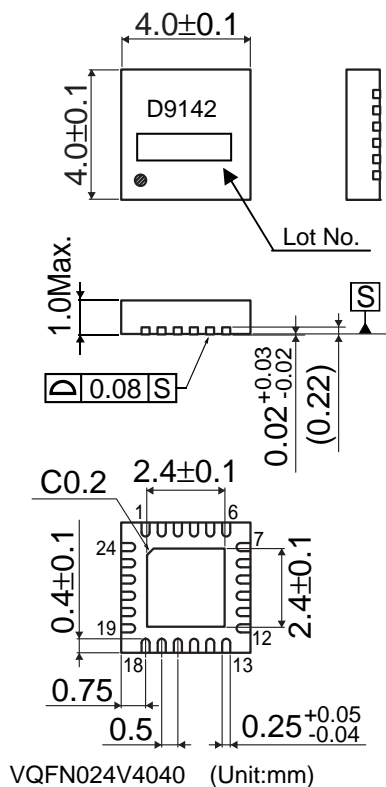

○BLOCK DIAGRAM

Pin No.	Pin name	Function
1	SW	SW pin
2	SW	SW pin
3	SW	SW pin
4	SW	SW pin
5	SW	SW pin
6	SW	SW pin
7	N.C.	Non Connection
8	PVCC	Highside FET drain pin
9	PVCC	Highside FET drain pin
10	BST	Bootstrapped voltage input pin
11	QVCC	QVCC power supply input pin
12	DET	Detector pin
13	N.C.	Non Connection
14	AVCC	AVCC power supply input pin
15	N.C.	Non Connection
16	AGND	Ground
17	EN	Enable pin (High Active)
18	CTL	External FET control pin
19	ADJ	Output voltage detect pin
20	ITH	GmAmp output pin
21	VREG	Internal voltage regulator
22	PGND	Lowside FET source pin
23	PGND	Lowside FET source pin
24	N.C.	Non Connection

○APPLICATION CIRCUIT1 (Dual Input)

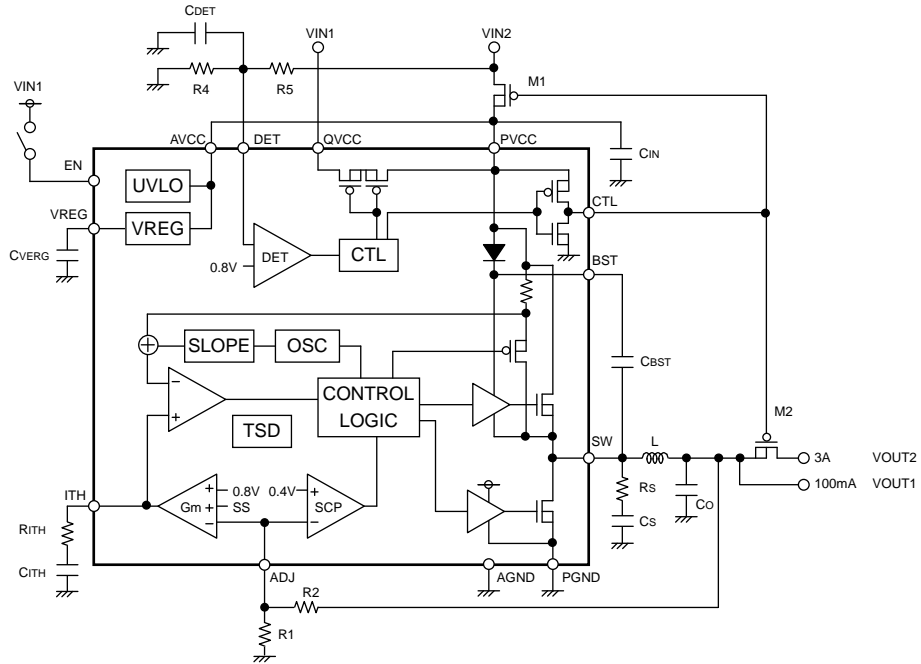

○APPLICATION CIRCUIT2 (Single Input)

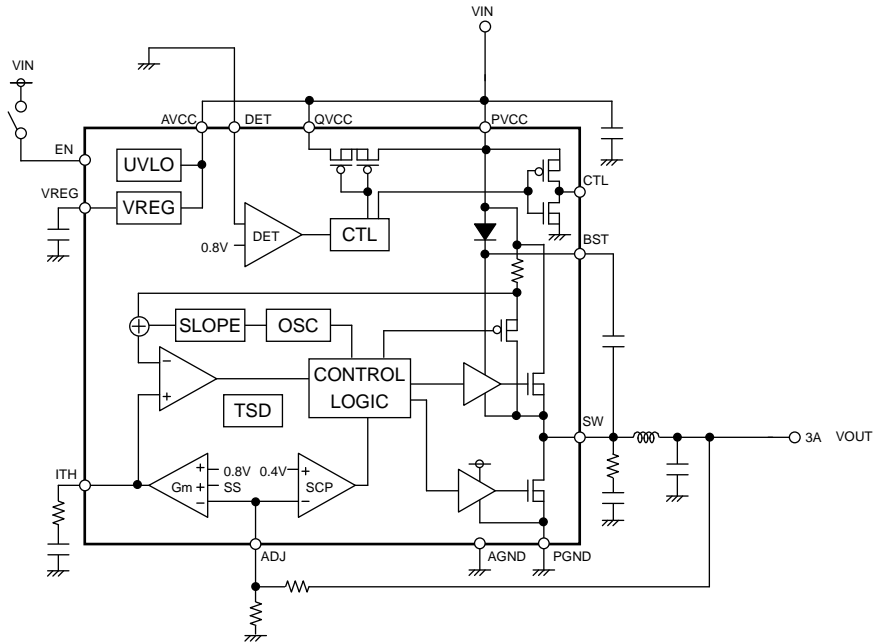

○SETTING THE OUTPUT VOLTAGE

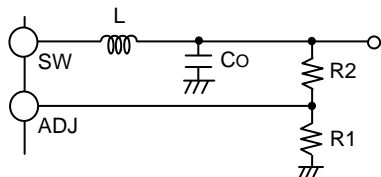

The Output Voltage is set by the external resistor divider and is calculated as :

$$V_{out} = (R2/R1 + 1) \times V_{ADJ} \dots \textcircled{1}$$

V<sub>ADJ</sub> : ADJ pin reference Voltage (0.8V typ)

It's possible to adjust the output voltage by R1 and R2.  
(The V<sub>out</sub> must be set from 1.0V to 3.3V.)  
Resistance R1 ≧ 10kΩ is recommended. Please confirm the ripple voltage, if you can use the resistance more than 100kΩ or they have a big range between the setting value of output voltage and input voltage.

## ○NOTES FOR USE

## (1) Absolute Maximum Ratings

We are careful enough for quality control about this IC. So, there is no problem under normal operation, excluding that it exceeds the absolute maximum ratings. However, this IC might be destroyed when the absolute maximum ratings, such as impressed voltages or the operating temperature range, is exceeded, and whether the destruction is short circuit mode or open circuit mode cannot be specified. Take into consideration the physical countermeasures for safety, such as fusing, if a particular mode that exceeds the absolute maximum rating is assumed.

## (2) GND Potential

Make setting of the potential of the GND terminal so that it will be maintained at the minimum in any operating state. Furthermore, check to be sure no terminals are at a potential lower than the GND voltage except for SW, PGND, GND terminals including an actual electric transient.

## (3) Thermal design

Do not exceed the power dissipation (Pd) of the package specification rating under actual operation, and design enough temperature margins.

## (4) Short circuit mode between terminals and wrong mounting

In order to mount the IC on a set PCB, pay thorough attention to the direction and offset of the ICs. Erroneous mounting can destroy the IC. Furthermore, if a short circuit occurs due to foreign matters entering between terminals or between the terminal and the power supply or the GND terminal, the IC can destroy

## (5) Operation in Strong electromagnetic field

Be noted that using the IC in the strong electromagnetic radiation can cause operation failures.

## (6) TSD(Thermal Shut-Down) circuit

The thermal shutdown circuit (TSD circuit) is built in this product. When IC chip temperature becomes higher, the thermal shutdown circuit operates and turns output off. The guarantee and protection of IC are not purpose. Therefore, do not use this IC after TSD circuit operates, nor use it for assumption that operates the TSD circuit.

## (7) GND wiring pattern

Use separate ground lines for control signals and high current power driver outputs. Because these high current outputs that flows to the wire impedance changes the GND voltage for control signal. Therefore, each ground terminal of IC must be connected at the one point on the set circuit board. As for GND of external parts, it is similar to the above-mentioned.

## (8) Operation in supply voltage range

Functional Circuit operation is guaranteed within operation ambient temperature, as long as it is within operation supply voltage range. The electrical characteristics standard value cannot be guaranteed. However, there is no drastic variation in these values, as long as it is within operation supply voltage range.

## (9) We are confident in recommending the above application circuit example, but we ask that you carefully check the characteristics of this circuit before using it. If using this circuit after modifying other external circuit constants, be careful to ensure adequate margins for variation between external devices and this IC, including not only static characteristics but also transient characteristics. If switching noise is high, insert the Low pass filter between Vcc pin and PVcc pin, insert the schottky barrier diodes between SW pin and PGND pin.

## (10) Overcurrent protection circuit

The overcurrent protection circuit is built in the output. If the protection circuit operates more than for specific hours (when the load is short.), the output will be latched in OFF. The output returns when EN is turned on or UVLO is released again. These protection circuits are effective in the destruction prevention by broken accident. Do not use in continuous circuit operation.

## (11) Selection of inductor

It is recommended to use an inductor with a series resistance element (DCR)  $0.1\ \Omega$  or less. Note that use of a high DCR inductor will cause an inductor loss, resulting in decreased output voltage. Should this condition continue for a specified period (soft start time + timer latch time), output short circuit protection will be activated and output will be latched OFF. When using an inductor over  $0.1\ \Omega$ , be careful to ensure adequate margins for variation between external devices and this IC, including transient as well as static characteristics.

## Notes

No copying or reproduction of this document, in part or in whole, is permitted without the consent of ROHM Co.,Ltd.

The content specified herein is subject to change for improvement without notice.

The content specified herein is for the purpose of introducing ROHM's products (hereinafter "Products"). If you wish to use any such Product, please be sure to refer to the specifications, which can be obtained from ROHM upon request.

Examples of application circuits, circuit constants and any other information contained herein illustrate the standard usage and operations of the Products. The peripheral conditions must be taken into account when designing circuits for mass production.

Great care was taken in ensuring the accuracy of the information specified in this document. However, should you incur any damage arising from any inaccuracy or misprint of such information, ROHM shall bear no responsibility for such damage.

The technical information specified herein is intended only to show the typical functions of and examples of application circuits for the Products. ROHM does not grant you, explicitly or implicitly, any license to use or exercise intellectual property or other rights held by ROHM and other parties. ROHM shall bear no responsibility whatsoever for any dispute arising from the use of such technical information.

The Products specified in this document are intended to be used with general-use electronic equipment or devices (such as audio visual equipment, office-automation equipment, communication devices, electronic appliances and amusement devices).

The Products specified in this document are not designed to be radiation tolerant.

While ROHM always makes efforts to enhance the quality and reliability of its Products, a Product may fail or malfunction for a variety of reasons.

Please be sure to implement in your equipment using the Products safety measures to guard against the possibility of physical injury, fire or any other damage caused in the event of the failure of any Product, such as derating, redundancy, fire control and fail-safe designs. ROHM shall bear no responsibility whatsoever for your use of any Product outside of the prescribed scope or not in accordance with the instruction manual.

The Products are not designed or manufactured to be used with any equipment, device or system which requires an extremely high level of reliability the failure or malfunction of which may result in a direct threat to human life or create a risk of human injury (such as a medical instrument, transportation equipment, aerospace machinery, nuclear-reactor controller, fuel-controller or other safety device). ROHM shall bear no responsibility in any way for use of any of the Products for the above special purposes. If a Product is intended to be used for any such special purpose, please contact a ROHM sales representative before purchasing.

If you intend to export or ship overseas any Product or technology specified herein that may be controlled under the Foreign Exchange and the Foreign Trade Law, you will be required to obtain a license or permit under the Law.



Thank you for your accessing to ROHM product informations.  
More detail product informations and catalogs are available, please contact us.

## ROHM Customer Support System

<http://www.rohm.com/contact/>