

## APR9600

### Single-Chip Voice Recording & Playback Device 60-Second Duration

#### Features

- Single-chip, high-quality voice recording & playback solution
  - No external ICs required
  - Minimum external components
- Non-volatile Flash memory technology
  - No battery backup required
- User-Selectable messaging options
  - Random access of multiple fixed-duration messages
  - Sequential access of multiple variable-duration messages
- User-friendly, easy-to-use operation
  - Programming & development systems not required
  - Level-activated recording & edge-activated playback switches
- Low power consumption
  - Operating current: 25 mA typical
  - Standby current: 1 uA typical
  - Automatic power-down
- Chip Enable pin for simple message expansion

#### General Description

The APR9600 device offers true single-chip voice recording, non-volatile storage, and playback capability for 40 to 60 seconds. The device supports both random and sequential access of multiple messages. Sample rates are user-selectable, allowing designers to customize their design for unique quality and storage time needs. Integrated output amplifier, microphone amplifier, and AGC circuits greatly simplify system design. The device is ideal for use in portable voice recorders, toys, and many other consumer and industrial applications.

APLUS integrated achieves these high levels of storage capability by using its proprietary analog/multilevel storage technology implemented in an advanced Flash non-volatile memory process, where each memory cell can store 256 voltage levels. This technology enables the APR9600 device to reproduce voice signals in their natural form. It eliminates the need for encoding and compression, which often introduce distortion.

#### Pinout Diagram

Figure 1 APR9600 Pinout Diagram

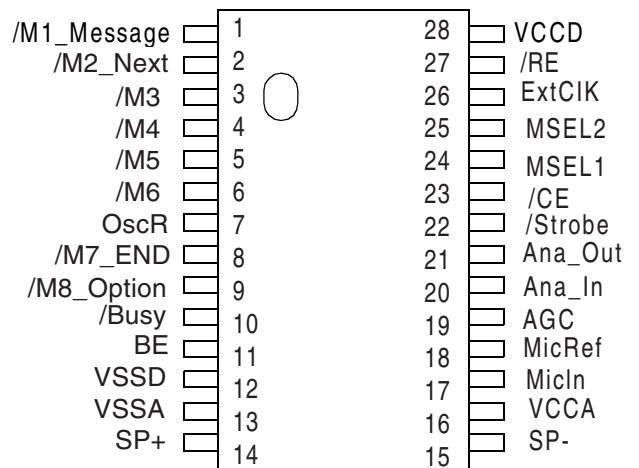

## Functional Description

The APR9600 block diagram is included in order to give understanding of the APR9600 internal architecture. At the left hand side of the diagram are the analog inputs. A differential microphone amplifier, including integrated AGC, is included on-chip for applications requiring its use. The amplified microphone signal is fed into the device by connecting the Ana\_Out pin to the Ana\_In pin through an external DC blocking capacitor. Recording can be fed directly into the Ana\_In pin through a DC blocking capacitor, however, the connection between Ana\_In and Ana\_Out is still required for playback. The next block encountered by the input signal is the internal anti-aliasing filter. The filter automatically adjusts its response according to the sampling frequency selected so Shannon's Sampling Theorem is satisfied. After anti-aliasing filtering is accomplished the signal is ready to be clocked into the memory array. This storage is accomplished through a

combination of the Sample and Hold circuit and the Analog Write/Read circuit. These circuits are clocked by either the Internal Oscillator or an external clock source. When playback is desired the previously stored recording is retrieved from memory, low pass filtered, and amplified as shown on the right hand side of the diagram. The signal can be heard by connecting a speaker to the SP+ and SP- pins. Chip-wide management is accomplished through the device control block shown in the upper right hand corner. Message management is controlled through the message control block represented in the lower center of the block diagram. More detail on actual device application can be found in the *Sample Applications* section. More detail on sampling control can be found in the *Sample Rate and Voice Quality* section. More detail on message management and device control can be found in the *Message Management* section.

**Figure 2 APR9600 Block Diagram**

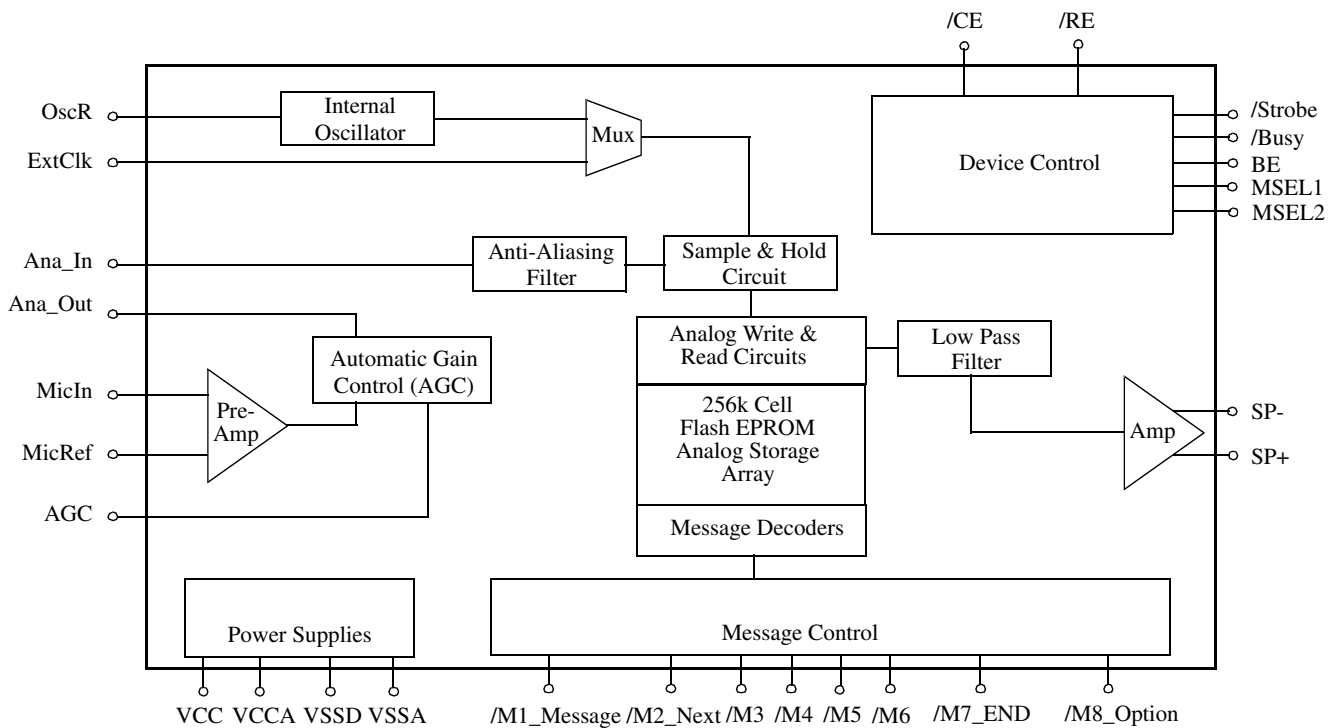

## Message Management

### Message Management General Description

Playback and record operations are managed by on chip circuitry. There are several available messaging modes depending upon desired operation. These message modes determine message management style, message length, and external parts count. Therefore, the designer must select the appropriate operating mode *before* beginning the design. Operating modes do *not* affect voice quality; for information on factors affecting quality refer to the *Sampling Rate & Voice Quality* section.

The device supports three message management modes (defined by the MSEL1, MSEL2 and /M8\_Option pins shown in Figures 1 and 2):

- Random access mode with 2, 4, or 8 fixed-duration messages

- Tape mode, with multiple variable-duration messages, provides two options:

- Auto rewind
- Normal

Modes cannot be mixed. Switching of modes after the device has recorded an initial message is not recommended. If modes are switched after an initial recording has been made some unpredictable message fragments from the previous mode may remain present, and be audible on playback, in the new mode. These fragments will disappear after a record operation in the newly selected mode. Table 1 defines the decoding necessary to choose the desired mode.

An important feature of the APR9600 message management capabilities is the ability to audibly prompt the user to changes in the device's status through the use of "beeps" superimposed on the device's output. This feature is enabled by asserting a logic high level on the BE pin.

**Table 1**

Mode	MSEL1	MSEL2	/M8_Option
Random Access 2 fixed duration messages	0	1	Pull this pin to VCC through 100K resistor
Random Access 4 fixed duration messages	1	0	Pull this pin to VCC through 100K resistor
Random Access 8 fixed duration messages	1	1	Becomes the /M8 message trigger input pin
Tape mode, Normal operation	0	0	0
Tape mode, Auto rewind operation	0	0	1

### Random Access Mode

Random access mode supports 2, 4, or 8 messages segments of fixed duration. As suggested recording or playback can be made randomly in any of the selected messages. The length of each message segment is the total recording length available (as defined by the selected sampling rate) divided by the total number of segments enabled (as decoded in Table1). Random access mode provides easy indexing to message segments.

#### Functional Description of Recording in Random Access Mode

On power up, the device is ready to record or play back, in any of the enabled message segments. To record, /CE must be set low to enable the device and /RE must be set low to enable recording. You initiate recording by applying a low level on the message trigger pin that represents the message segment you intend to use. The message trigger pins are labeled /M1\_Message - /M8\_Option on pins 1-9 (excluding pin 7) for message segments 1-8 respectively.

**Note:** Message trigger pins /M1\_Message, /M2\_Next, /M7\_END, and /M8\_Option, have expanded names to represent the different functionality that these pins

assume in the other modes. In random access mode these pins should be considered purely message trigger pins with the same functionality as /M3, /M4, /M5, and /M6. For a more thorough explanation of the functionality of device pins in different modes please refer to the pin description table that appears later in this document.

When actual recording begins the device responds with a single beep (if the BE pin is high to enable the beep tone) at the speaker outputs to indicate that it has started recording. Recording continues as long as the message pin stays low. The rising edge of the same message trigger pin during record stops the recording operation (indicated with a single beep).

If the message trigger pin is held low beyond the end of the maximum allocated duration, recording stops automatically (indicated with two beeps), regardless of the state of the message trigger pin. The chip then enters low-power mode until the message trigger pin returns high. After the message trigger pin returns to high, the chip enters standby mode. Any subsequent high to low transition on the same message trigger pin will initiate recording from the beginning of the same

message segment. The entire previous message is then overwritten by the new message, regardless of the duration of the new message. Transitions on any other message trigger pin or the /RE pin during the record operation are ignored until *after* the device enters standby mode.

#### **Functional Description of Playback in Random Access Mode**

On power up, the device is ready to record or playback, in any of the enabled message segments. To playback, /CE must be set low to enable the device and /RE must be set high to disable recording & enable playback. You initiate playback by applying a high to low edge on the message trigger pin that representing the message segment you intend to playback. Playback will continue until the end of the message is reached. If a high to low edge occurs on the *same* message trigger pin during playback, playback of the current message stops immediately.

If a different message trigger pin pulses during playback, playback of the current message stops immediately (indicated by one beep) and playback of the new message segment begins. A delay equal to 8,400 cycles of the sample clock will be encountered before the device starts playing the new message.

If a message trigger pin is held low, the selected message is played back repeatedly as long as the trigger pin stays low. A period of silence, of a duration equal to 8,400 cycles of the sampling clock, will be inserted during looping as an indicator to the user of the transition between the end and the beginning of the message.

#### **Tape Mode**

Tape mode manages messages sequentially much like traditional cassette tape recorders. Within tape mode two options exist, auto rewind and normal. Auto rewind mode configures the device to automatically rewind to the beginning of the message immediately following recording or playback of the message. In tape mode, using either option, messages must be recorded or played back sequentially, much like a traditional cassette tape recorder.

#### **Function Description Recording in Tape Mode using the Normal Option**

On power up, the device is ready to record or play back, starting at the first address in the memory array. To record, /CE must be set low to enable the device and /RE must be set low to enable recording. A falling edge of the /M1\_Message pin initiates voice recording (indicated by one beep). A subsequent rising edge of the /M1\_Message pin during recording stops the recording (also indicated by one beep). If the /M1\_Message pin is held low beyond the end of the available memory, recording will stop automatically (indicated by two beeps). The device will then assert a logic low on the /M7\_END pin for a duration equal to 1600 cycles of the sam-

ple clock, regardless of the state of the /M1\_Message pin.

The device returns to standby mode when the /M1\_Message pin goes high again.

After recording is finished the device will automatically rewind to the beginning of the most recently recorded message and wait for the next user input. The auto rewind function is convenient because it allows the user to immediately playback and review the message without the need to rewind. However, caution must be practiced because a subsequent record operation will overwrite the last recorded message unless the user remembers to pulse the /M2\_Next pin in order to increment the device past the current message.

A subsequent falling edge on the /M1\_Message pin starts a new record operation, overwriting the previously existing message. You can preserve the previously recorded message by using the /M2\_Next input to initiate recording in the next available message segment. To perform this function, the /M2\_Next pin must be pulled low for at least 400 cycles of the sample clock.

The auto rewind mode allows the user to record over the previous message simply by initiating a record sequence without first toggling the /M2\_Next pin. To record over any other message however requires a different sequence. You must pulse the /CE pin low once to rewind the device to the beginning of the voice memory. The /M2\_Next pin must then be pulsed low for the specified number of times to move to the start of the message you wish to overwrite. Upon arriving at the desired message a record sequence can be initiated to overwrite the previously recorded material. After you overwrite the message it becomes the last available message and all previously recorded messages following this message become inaccessible. If during a record operation all the available memory is used the device will stop recording automatically, (double beep) and set the /M7\_END pin low for a duration equal to 1600 cycles of the sample clock. Playback can be initiated on this last message, but pulsing the /M2\_Next pin will put the device into an "overflow state".

Once the device enters an overflow state any subsequent pulsing of /M1\_Message or /M2\_Next will only result in a double beep and setting of the /M7\_END pin low for a duration equal to 400 cycles of the sample clock. To proceed from this state the user must rewind the device to the beginning of the memory array. This can be accomplished by toggling the /CE pin low or cycling power. All inputs, except the /CE pin, are ignored during recording.

**Function Description of Playback in Tape Mode using the Normal Option**

On power-up, the device is ready to record or play back, starting at the first address in the memory array. Before you can begin playback, the /CE input must be set to low to enable the device and /RE must be set to high to disable recording and enable playback. The first high to low going pulse of the /M1\_Message pin initiates playback from the beginning of the current message; on power up the first message is the current message. When the /M1\_Message pin pulses low the second time, playback of the current message stops immediately. When the /M1\_Message pin pulses low a third time, playback of the current message starts again from its beginning. If you hold the /M1\_Message pin low continuously the same message will play continuously in a looping fashion. A 1,530 ms period of silence is inserted during looping as an indicator to the user of the transition between the beginning and end of the message.

Note that in auto rewind mode the device always rewinds to the beginning of the current message. To listen to a subsequent message the device must be fast forwarded past the current message to the next message. This function is accomplished by toggling the /M2\_Next pin from high to low. The pulse must be low for least 400 cycles of the sampling clock. After the device is incremented to the desired message the user can initiate playback of the message with the playback sequence described above. A special case exists when the /M2\_Next pin goes low during playback. Playback of the current message will stop, the device will beep, advance to the next message and initiate playback of the next message. (Note that if /M2\_Next goes low when not in playback mode, the device will prepare to play the next message, but will not actually initiate playback).

If the /CE pin goes low during playback, playback of the current message will stop, the device will beep, reset to the beginning of the first message, and wait for a subsequent playback command.

When you reach the end of the memory array, any subsequent pulsing of /M1\_Message or /M2\_Next will only result in a double beep. To proceed from this state the user must rewind the device to the beginning of the memory array. This can be accomplished by toggling the /CE pin low or cycling power.

**Functional Description of Recording in Tape Mode using Auto Rewind Option**

On power-up, the device is ready to record or play back, starting at the first address in the memory array. Before you can begin recording, the /CE input must be set to low to enable the device and /RE must be set to low to enable recording. On a falling edge of the /M1\_Message pin the device will beep once and initiate recording. A subsequent rising edge on the /M1\_Message pin will stop recording and insert a single beep. If the /M1\_Message pin is held low

beyond the end of the available memory, recording stops automatically, and two beeps are inserted; regardless of the state of the /M1\_Message pin. The device returns to the standby mode when the /M1\_Message pin is returned high.

A subsequent falling edge on the /M1\_Message pin starts a new record operation in the memory array immediately following the last recorded message, thus preserving the last recorded message.

To record over all previous messages you must pulse the /CE pin low once to reset the device to the beginning of the first message. You can then initiate a record sequence, as described above, to record a new message. The most recently recorded message will become the last recorded message and all previously recorded messages following this message will become inaccessible.

If you wish to preserve any current messages it is recommend that Auto Rewind option be used instead of Normal option. If Normal option is necessary the following sequence can be used. To preserve current messages you must fast forward past the messages you want to keep before you can record a new message. To fast forward when using the Normal option you must switch to play mode and listen to messages sequentially until you arrive at the beginning of the message you wish to overwrite. At this stage you should switch back to record mode and overwrite the desired message. The most recently recorded message will become the last recorded message and all previously recorded messages following this message will become inaccessible. All inputs, except /CE are ignored during recording.

**Functional Description of Playback in Tape Mode using Auto Rewind Option**

On power-up, or after a low to high transition on /RE the device is ready to record or play back starting at the first address in the memory array. Before you can begin playback of messages, the /CE input must be set to low to enable the device and /RE must be set to high to enable playback. The first high to low going pulse of the /M1\_Message pin initiates playback from the beginning of the current message. When the /M1\_Message pin pulses from high to low a second time, playback of the current message stops immediately. When the /M1\_Message pin pulses from high to low a third time, playback of the next message starts again from the beginning. If you hold the /M1\_Message pin low continuously, the current message and subsequent messages play until the one of the following conditions is met: the end of the memory array is reached, the last message is reached, the /M1\_message pin is released. If the last recorded message has already played, any further transitions on the /M1\_Message pin will initiate a double beep for warning and the /M7\_END pin will go low. To exit this state you must pulse the /CE pin low once during standby to reset the pointer to the beginning of the first message.



## Microprocessor Controlled Message Management

The APR9600 device incorporates several features designed to help simplify microprocessor controlled message management. When controlling messages the microprocessor essentially toggles pins as described in the message management sections describe previously. The /Busy, /Strobe, and /M7\_END pins are included to simplify handshaking between the microprocessor and the APR9600

The /Busy pin when low indicates to the host processor that the device is busy and that no commands can be currently accepted. When this pin is high the device is ready to accept and execute commands from the host.

The /Strobe pin pulses low each time a memory segments is used. Counting pulses on this pin enables the host processor to accurately determine how much recording time has been used, and how much recording time remains. The APR9600 has a total of eighty memory segments.

The /M7\_END pin is used as an indicator that the device has stopped its current record or playback operation. During recording a low going pulse indicates that all memory has been used. During playback a low pulse indicates that the last message has played.

Microprocessor control can also be used to link several APR9600 devices together in order to increase total available recording time. In this application both the speaker and microphone signals can be connected in parallel. The microprocessor will then control which device currently drives the speaker by enabling or disabling each device using their respective /CE pins. A continuous message can not be recorded in multiple devices however because the transition from one device to the next will incur a delay that is noticeable upon playback. For this reason it is recommended that message boundaries and device boundaries always coincide.

## Signal Storage

The APR9600 samples incoming voice signals and stores the instantaneous voltage samples in non-volatile FLASH memory cells. Each memory cell can support voltage ranges from 0 to 256 levels. These 256 discrete voltage levels are the equivalent of 8-bit ( $2^8=256$ ) binary encoded values. During playback the stored signals are retrieved from memory, smoothed to form a continuous signal, and then amplified before being fed to an external speaker.

## Sampling Rate & Voice Quality

According to the Shannon's sampling theorem, the highest possible frequency component introduced to the input of a sampling system must be equal to or less than half the sampling frequency if aliasing errors are to be eliminated. The APR9600 automatically filters its input, based on the selected sampling frequency, to meet this requirement.

Higher sampling rates increase the bandwidth and hence the voice quality, but they also use more memory cells for the same length of recording time. Lower sampling rates use fewer memory cells and effectively increase the duration capabilities of the device, but they also reduce incoming signal bandwidth. The APR9600 accommodates sampling rates as high as 8 kHz and as low a 4 kHz. You can control the quality/duration trade off by controlling the sampling frequency.

An internal oscillator provides the APR9600 sampling clock. Oscillator frequency can be changed by changing the resistance from the OscR pin to GND. Table 2 summarizes resistance values and the corresponding sampling frequencies, as well as the resulting input bandwidth and duration.

**Table 2 Reference Rosc Value & Sampling Frequency**

Ref Rosc	Sampling Frequency	Input Bandwidth	Duration
84 K	4.2 kHz	2.1 kHz	60 sec
38 K	6.4 kHz	3.2 kHz	40 sec
24 K	8.0 kHz	4.0 kHz	32 sec

NOTICE: Rosc table above is for reference only, different lots ICs will have somewhat different Rosc value performance..

## Sampling Application

The following reference schematics are included as examples on how a recording system might be designed. Each reference schematic shows the device incorporated in one of its' three main modes, Random Access, Tape mode - Normal option, and Tape mode - Auto Rewind option. Note that in several of the applications either one or all of the /Busy, /Strobe, or /M7\_END pins are connected to LEDs as indicators of device status. This is possible because all of these pins and signals were designed to have timing compatible with both microprocessor interface and manual LED indication. Figure 3 shows the device configured in tape mode, normal operation. This mode is the minimal part count

application of the APR9600 Sampling rate is determined by the resistor value on pin 7 (OscR). The RC network on pin 19 sets the AGC "attack time".

A bias must be applied to the electret microphone in order to power its built in circuitry. The ground return of this bias network is connected to the normally open side of the record push button. This configuration gates power to microphone so that it is biased only during recording. This configuration saves power when not recording by shutting off power to the electret microphone. Both pins 18 and 19, MicIn and MicRef, must be AC couple to the microphone network in order to block the DC biasing voltage.

**Figure 3 Tape Mode, Normal Option**

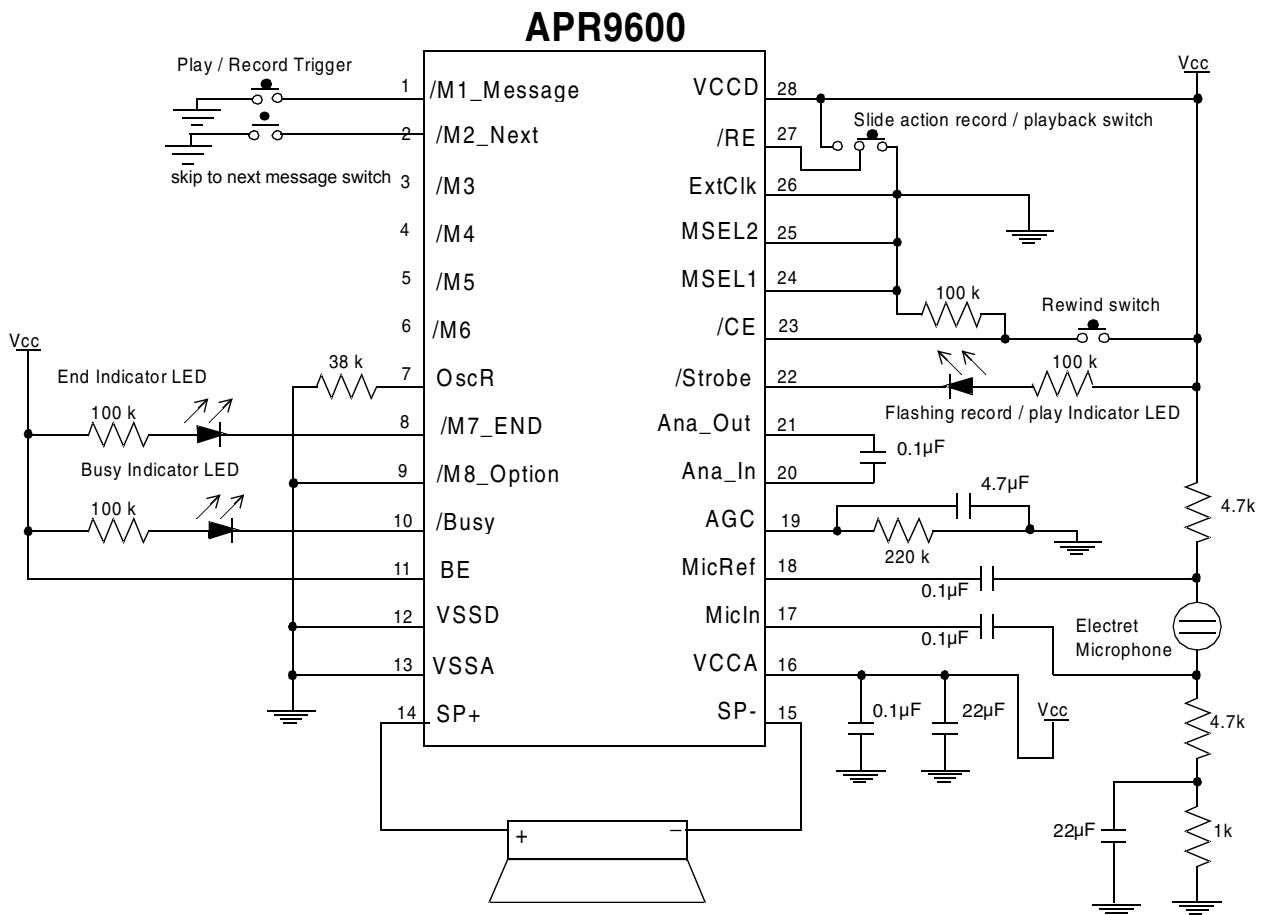

Figure 4 shows the device configured in tape mode, using the auto rewind option. Auto rewind is convenient for systems designed to store multiple messages. Auto rewind option does slightly increase parts count above that required for nor-

mal option. The Busy pin, /Strobe, and /M7\_END are again connected to LEDs to offer indication to the user of device status.

**Figure 4 Tape Mode, Auto Rewind Option**

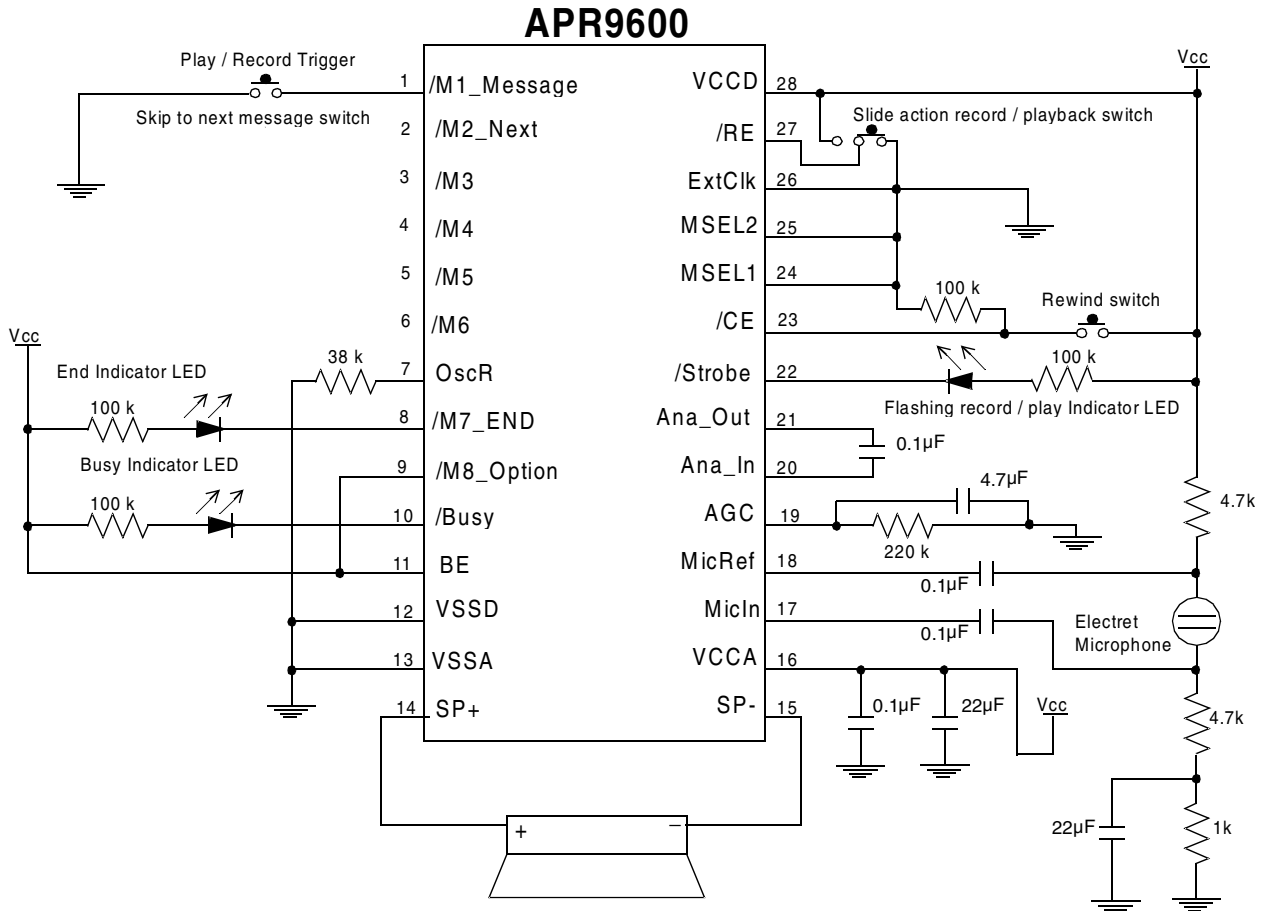
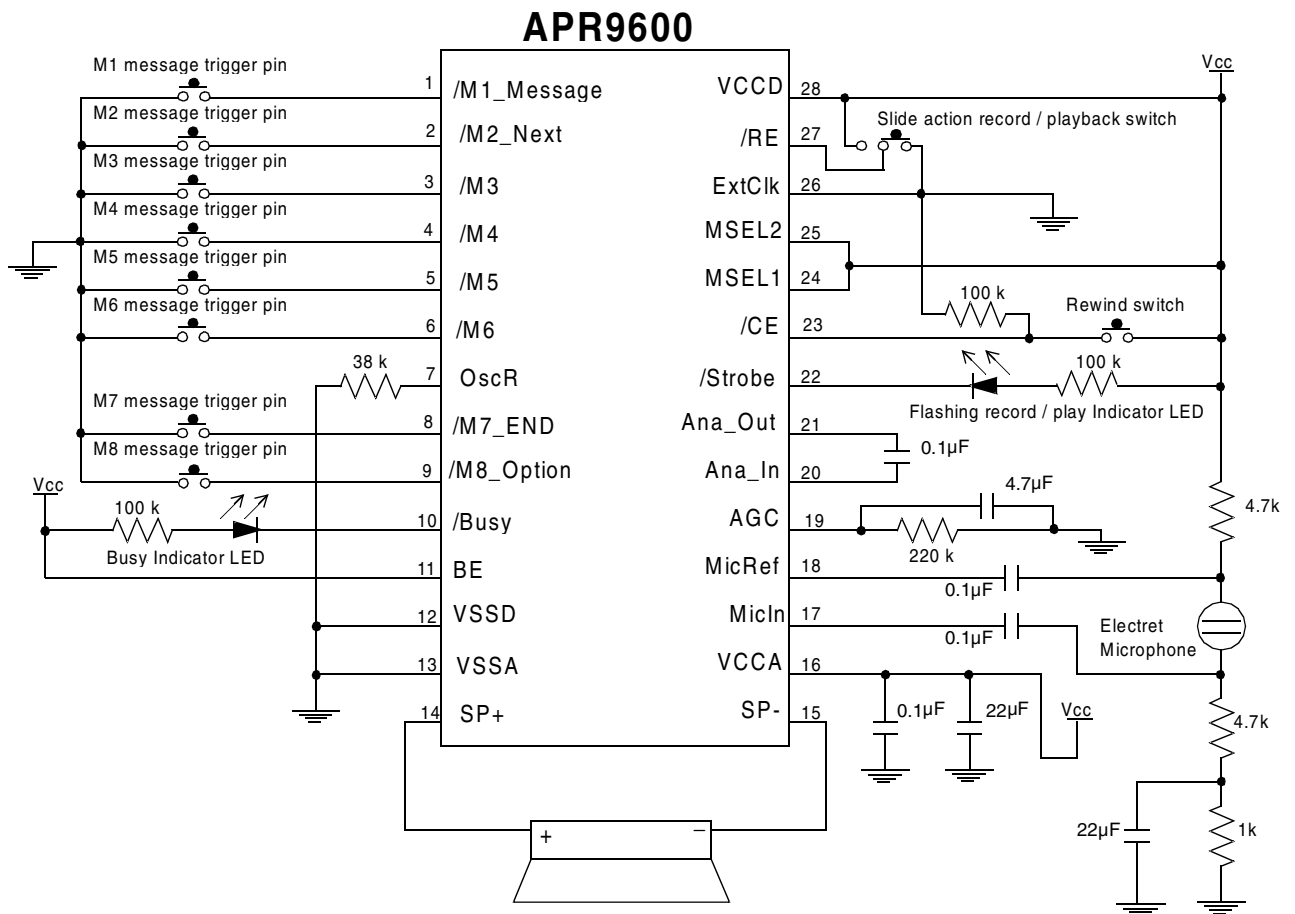



Figure 5 shows the device configured in random access mode. The device is using eight message segments, the maximum available, in this mode. Note that message trigger pins that are not used, for modes with less than eight segments,

can be left unconnected with the exception of pin /M8\_Option which should be pulled to VCC through a 100k resistor

**Figure 5 Random Access Mode**



## Pin Descriptions

**Table 1**

Pin Name	Pin No.	Functionality in Random Access Mode	Functionality in Tape Mode	
			Normal Option	Auto Rewind Option
/M1_Message	1	Message 1: This pin forces a jump to message 1 for either recording or playback.	Message: A low edge on this pin plays or records the next message.	Message: A low edge on this pin plays or records the current message.
/M2_Next	2	Message 2: This pin forces a jump to message 2 for either recording or playback.	Next Message: This active low input pin forces a skip to the next message for either playback or recording	This pin should be left unconnected when the device is used in this mode.
/M3	3	Message 3: This pin forces a jump to message 3 for either recording or playback.	This pin should be left unconnected when the device is used in this mode.	This pin should be left unconnected when the device is used in this mode.
/M4	4	Message 4: This pin forces a jump to message 4 for either recording or playback	This pin should be left unconnected when the device is used in this mode.	This pin should be left unconnected when the device is used in this mode.
/M5	5	Message 5: This pin forces a jump to message 5 for either recording or playback.	This pin should be left unconnected when the device is used in this mode.	This pin should be left unconnected when the device is used in this mode.
/M6	6	Message 6: This pin forces a jump to message 6 for either recording or playback.	This pin should be left unconnected when the device is used in this mode.	This pin should be left unconnected when the device is used in this mode.
OscR	7	Oscillator Resistor: this input allows an external resistor to be connected to the tank circuit of the internal oscillator. Refer to table X for a list of resistors and their resultant sampling rates.	Same as Mode 1.	Same as Mode 1.
/M7_END	8	Message 7: This pin forces a jump to message 7 for either recording or playback.	During playback a low level on this pin indicates that all recorded messages have been played. During recording a low level on this pin indicates that the end of the memory array was reached.	During playback a low level on this pin indicates that all recorded messages have been played. During recording a low level on this pin indicates that the end of the memory array was reached.
/M8_Option	9	Message 8: This pin forces a jump to message 8 for either recording or playback.	Option: This pin in conjunction with MSEL1 and MSEL2 sets record and playback operating mode. Consult table 1 for decoding information.	MSEL1 and MSEL2 sets record and playback operating mode. Consult table 1 for decoding information.
/Busy	10	This pin indicates that the device is currently busy performing internal functions and can neither record nor playback at the current time.	Same as Mode 1.	Same as Mode 1.
BE	11	If this pin is pulled high Beep is enabled. If this pin is pulled low beep is disabled	Same as Mode 1.	Same as Mode 1.
VSSD	12	Digital GND Connection: Connect to system ground.	Same as Mode 1.	Same as Mode 1.
VSSA	13	Analog GND Connection: Connect system ground.	Same as Mode 1.	Same as Mode 1.

## Pin Descriptions

Pin Name	Pin No.	Functionality in Random Access Mode	Functionality in Tape Mode	
			Normal Option	Auto Rewind Option
SP+	14	Positive Output for Speaker Connection: Should be connected to the positive terminal of the output speaker. Total output power is 1 W into 16 ohms. Do not use speaker loads lower than 8 ohms or device damage may result.	Same as Mode 1.	Same as Mode 1.
SP-	15	Negative Output for Speaker Connection: Should be connected to the negative terminal of the output speaker.	Same as Mode 1.	Same as Mode 1.
VCCA	16	Analog Positive Power Supply: This connection supplies power for on-chip analog circuitry. Should be connected to the positive supply rail as outlined in the reference schematics.	Same as Mode 1.	Same as Mode 1.
MicIn	17	Microphone Input: Should be connected to the microphone input as outlined in the reference schematics.	Same as Mode 1.	Same as Mode 1.
MicRef	18	Microphone GND Reference: Should be connected to the microphone input as outlined in the reference schematics.	Same as Mode 1.	Same as Mode 1.
AGC	19	Automatic Gain Control Attack Time: The time constant of the RC network connected to this input determines the AGC attack time. The attack time is defined as the delay present before the AGC circuit begins to adjust gain. The values shown in the reference schematics have been optimized for voice applications.	Same as Mode 1.	Same as Mode 1.
Ana_In	20	Analog In: This pin must be connected to Ana_Out through a 0.1µF Capacitor.	Same as Mode 1.	Same as Mode 1.
Ana_Out	21	Analog Out: This pin must be connected to Ana_In through a 0.1µF Capacitor.	Same as Mode 1.	Same as Mode 1.
/Strobe	22	Strobe: This pin indicates programming of each individual recording segment. The falling edge represents the beginning of the sector. The rising edge indicates that the sector is half full.	Same as Mode 1.	Same as Mode 1.

## Pin Descriptions -cont.

Pin Name	Pin No.	Functionality in Random Access Mode	Functionality in Tape Mode	
			Normal Option	Auto Rewind Option
/CE	23	Chip Select: A low level on this pin enables the device for operation. Toggling this pin also resets several message management features.	Same as Mode 1.	Same as Mode 1.
MSEL1	24	Mode Select1: This pin in conjunction with MSEL2 and /M8_Option sets record and playback operating mode. Consult table 1 for decoding information.	Same as Mode 1.	Same as Mode 1.
MSEL2	25	Mode Select2: This pin in conjunction with MSEL1 and /M8_Option sets record and playback operating mode. Consult table 1 for decoding information.	Same as Mode 1.	Same as Mode 1.
ExtClk	26	External Clock: This clock can be used instead of the internal clock for greater programming control and or accuracy. When using the internal clock this pin should be tied to system GND.	Same as Mode 1.	Same as Mode 1.
/RE	27	Record Enable: this pin controls whether the device is in write or read mode. Logic level high is read.	Same as Mode 1.	Same as Mode 1.
VCCD	28	Digital Positive Power Supply: This connection supplies power for on-chip digital circuitry. Should be connected to the positive supply rail as outlined in the reference schematics.	Same as Mode 1.	Same as Mode 1.

## Electrical Characteristics

The following tables list Absolute Maximum Ratings, DC Characteristics, and Analog Characteristics for the APR9600 device.

### Absolute Maximum Ratings

Item	Symbol	Condition	Min	Max	Unit
Power Supply voltage	$V_{CC}$	$T_A = 25^\circ\text{C}$	-0.3	6.5	V
Input Voltage	$V_{IN2}$	$I_{IN} < 20\text{mA}$	-1.0	$V_{CC} + 1.0$	V
Storage Temperature	$T_{STG}$	-	-65	150	$^\circ\text{C}$
Temperature Under Bias	$T_{BS}$	-	-65	125	$^\circ\text{C}$
Lead Temperature	$T_{LD}$	$< 10\text{s}$	-0.3	300	$^\circ\text{C}$

### DC Characteristics

Item	Symbol	Condition	Min	Typ	Max	Unit
Power Supply voltage	$V_{CC}$	$T_A = 25^\circ\text{C}$	4.5	6.0	6.5	V
Input High Voltage	$V_{IH}$	-	2.0	-	-	V
Input Low Voltage	$V_{IL}$	-	-	-	0.8	V
Output High Voltage	$V_{OH}$	$I_{OH} = -1.6\text{mA}$	2.4	-	-	V
Output Low Voltage	$V_{OL}$	$I_{OL} = -4.0\text{mA}$	-	-	0.45	V
Input Leakage Current	$I_{IH}$	$V_{IH} = V_{CC}$	-	-	1.0	A
Input Leakage Current	$I_{IL}$	$V_{IL} = V_{SS}$	-1.0	-	-	A
Output Tristate Leakage Current	$I_{OZ}$	$V_{OUT} = V_{CC}$ or $V_{OUT} = V_{SS}$	-1.0	-	1.0	A
Operating Current Consumption	$I_{CC}$	Internal Clock, No Load	-	25	-	mA
Standby Current Consumption	$I_{CCS}$	No Load	-	1.0	-	uA

### Analog Characteristics\*

Item	Symbol	Condition	Min	Typ	Max	Unit
MicIn Input Voltage	$V_{MI}$	-	-	-	30	mV <sub>P-P</sub>
MicIn Input Resistance	$R_{MI}$	-	-	15	-	k
MicIn Amp Gain (1)	$G_{MI1}$	AGC=2.25v	-	30	-	dB
MicIn Amp Gain (2)	$G_{MI2}$	AGC=3.8V	-	-2	-	dB
AnaIn Input Voltage	$V_{ANI}$	-	-	-	140	mV <sub>P-P</sub>
AnaIn Input Resistance	$R_{ANI}$	-	-	500	-	k
AnaIn Amp Gain	$G_{ANI}$	AnaIn to SP+/-	-	10	-	dB
AGC Output Resistance	$R_{AGC}$	-	-	225	-	k
Sp+/- Output Power	$P_{SP}$	$R_{SP+/-} = 16$	-	12.2	-	mW
Voltage Amplitude across SP+/-	$V_{SP}$	$R_{SP+/-} \geq 16$	-	1.4	-	V <sub>P-P</sub>

# APLUS INTEGRATED CIRCUITS INC.

## APR9600 Bonding Pad Diagram and Bonding Pad Coordinates

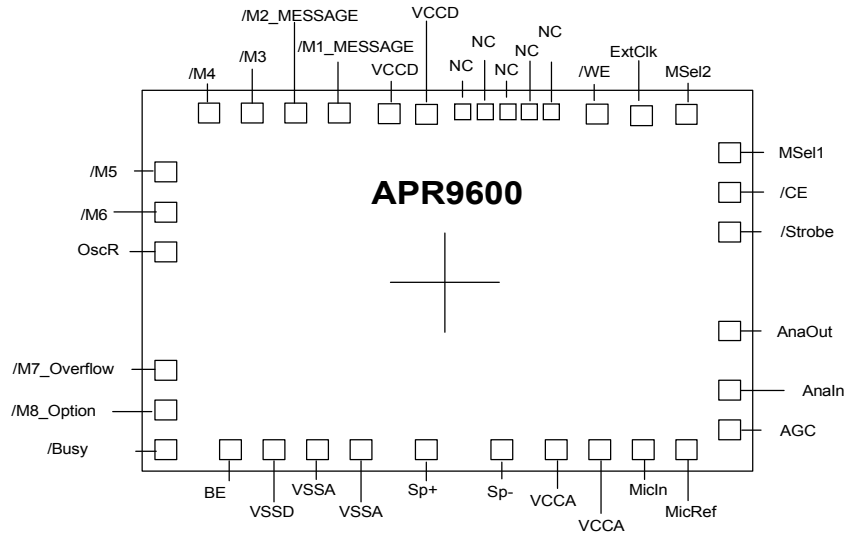

### Notes :

Die Dimensions X-Axis : 212 +/- 1 mils X-Axis : 5450  $\mu$ m  
 Y-Axis : 176 +/- 1 mils Y-Axis : 4550  $\mu$ m  
 Die Thickness 13.8 +/- 1.0 mils (350 +/- 25  $\mu$ m)  
 Pad Opening 4.3 mils (110  $\mu$ m)

The following table list the bonding pad coordinates for the APR9600 device. NOTE:All coordinates are with respect to the center of the die ( $\mu$ m).

Pin Name	X-Axis	Y-Axis		Pin Name	X-Axis	Y-Axis
/M1_Message	-1075	2007		MicIn	1708	-1969
/M2_Next	-1393	2007		MicRef	2064	-1969
/M3	-1833	2007		AGC	2491	-1865
/M4	-2151	2007		AnaIn	2491	-1513
/M5	-2513	1397		AnaOut	2491	-1013
/M6	-2513	1079		/Strobe	2514	696
OscR	-2513	617		/CE	2514	1182
/M7_Overflow	-2485	-865		MSel1	2514	1532
/M8_Option	-2485	-1193		MSel2	2121	2007
/Busy	-2435	-1987		ExtClk	1592	2007
BE	-1953	-1987		/WE	1088	2007
VSSD	-1728	-2003		VCCD	-577	2007
VSSA	-1532	-1976		VCCD	-757	2007
VSSA	-1337	-1952				
Sp +	-840	-1838				
Sp -	347	-1838				
VCCA	844	-1909				
VCCA	1066	-1951				



**OLD** APR9600 SOP RECORDING VOICE 40" ~ 60"

MODE	MSEL-1 ( PIN-24 )	MSEL-2 ( PIN-25 )	/M8 ( PIN-9 )
2 FIXED MESSAGES	0	1	Pull-high 100KOhm
4 FIXED MESSAGES	1	0	Pull-high 100KOhm
8 FIXED MESSAGES	1	1	/M8 trigger pin
1 FIXED MESSAGES	0	0	0
TAPE MODE -NEXT	0	0	0
TAPE MODE - AUTO	0	0	1

Ref. ROSC	Sampling Frequency	Inoput bandwidth	Voice duration
84 K Ohm	4.2 KHz	2.1 KHz	60 sec.
38 K Ohm	6.4 KHz	3.2 KHz	40 sec.
24 K Ohm	8.0 KHz	4.0 KHz	32 sec.

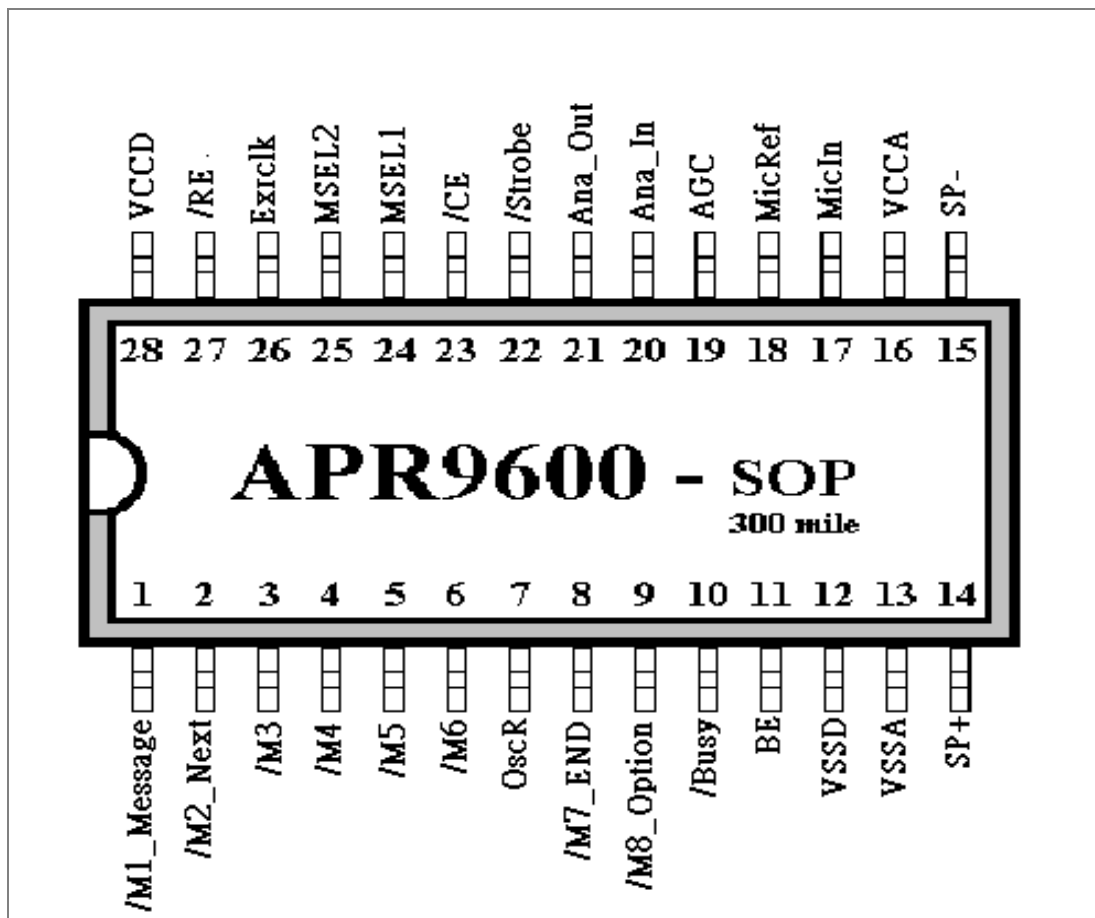

## NEW APR9600 SOP RECORDING VOICE 40" ~ 60"

MODE	MSEL-1 ( PIN-3 )	MSEL-2 ( PIN-4 )	/M8 ( PIN-16 )
2 FIXED MESSAGES	0	1	Pull-high 100KOhm
4 FIXED MESSAGES	1	0	Pull-high 100KOhm
8 FIXED MESSAGES	1	1	/M8 trigger pin
1 FIXED MESSAGES	0	0	0
TAPE MODE -NEXT	0	0	0
TAPE MODE - AUTO	0	0	1

Ref. ROSC	Sampling Frequency	Inoput bandwidth	Voice duration
84 K Ohm	4.2 KHz	2.1 KHz	60 sec.
38 K Ohm	6.4 KHz	3.2 KHz	40 sec.
24 K Ohm	8.0 KHz	4.0 KHz	32 sec.

