

iT2005F

30 kHz to 18 GHz Power Amplifier

Description

The iT2005F is a RoHS-6-compliant packaged broadband amplifier designed for medium output power applications where low-frequency capabilities are also required. The iT2005F provides saturated output power of 25 dBm up to 8 GHz and greater than 23 dBm up to 18 GHz with average gain of 15 dB. DC power consumption is as low as 1.76 W. Input/output ports are DC coupled.

Features

- Frequency range: 30 KHz – 18 GHz
- 25 dBm nominal Psat (30 KHz – 12 GHz)
- 23 dBm nominal Psat (12 GHz – 18 GHz)
- 15 dB nominal gain
- 1.76 W DC power consumption
- Nominal DC bias conditions: 8 V at 220 mA
- “F” type 5x5 mm QFN RoHS-6-compliant package



Absolute Maximum Ratings

| Symbol | Parameters/conditions | Min. | Max. | Units |
|----------------------|-------------------------------|------|------|-------|
| V _{DD} | Positive supply voltage | | 10 | V |
| V _{G1} | Negative supply voltage | -2 | 0 | V |
| I _{DD} | Positive supply current | | 600 | mA |
| I _{G1} | Negative supply current | | 1.8 | mA |
| P _{in} | RF input power | | 23 | dBm |
| P _{diss_DC} | DC power dissipation (no RF) | | 4 | W |
| T _{ch} | Operating channel temperature | | 150 | °C |
| T _m | Mounting temperature (30 s) | | 320 | °C |
| T _{st} | Storage temperature | -65 | 150 | °C |

Electrical Characteristics

(at 25 °C) 50-ohm system, V_{dd} = +8 V, Quiescent current (I_{DQ}) = 220 mA, V_{g2} = +3.4 V

| Symbol | Min. | Typ. | Max. | Min. | Typ. | Max. | Min. | Typ. | Max. | Units |
|------------------|-------------|------|------|------------|------|------|-------------|------|------|-------|
| Frequency | 30KHz – 2.0 | | | 2.0 – 12.0 | | | 12.0 – 18.0 | | | GHz |
| Gain | | 16.5 | | | 15.5 | | | 12.0 | | dB |
| Gain flatness | | ±0.5 | | | ±1 | | | ±1 | | dB |
| S ₁₁ | -8 | -12 | | -10 | -12 | | -8 | -12 | | dB |
| S ₂₂ | -15 | -20 | | -12 | -18 | | -8 | -10 | | dB |
| P _{sat} | 24 | 26 | | 23 | 25 | | 21 | 23 | | dBm |
| P _{1dB} | 23 | 25 | | 22 | 24 | | 19 | 21 | | dBm |
| OIP3 | | | | | 28 | | | 24 | | dBm |



Thermal Characteristics

| Symbol | Parameters/conditions | Rth_jb (°C/W) | Tch (° C) | MTTF (h) |
|--------|-------------------------------------------------------------------------------------------------------------------------------------------|---------------|-----------|----------|
| Rth_jb | Thermal resistance junction: Ground paddle. No RF: DC bias Vdd = 8 VDC, I _{DD} = 220 mA, P _{DC} = 1.76 W, Tbase = 70° C | 18.5 | 99.0 | >>+1E7 |
| Rth_jb | Thermal resistance junction: Ground paddle. RF applied: Saturated power 500 mW, Vdd = 8 VDC, P _{diss} = 2.15 W, Tbase = 70° C | 18.5 | 113.0 | >>+1E7 |

Device Diagram

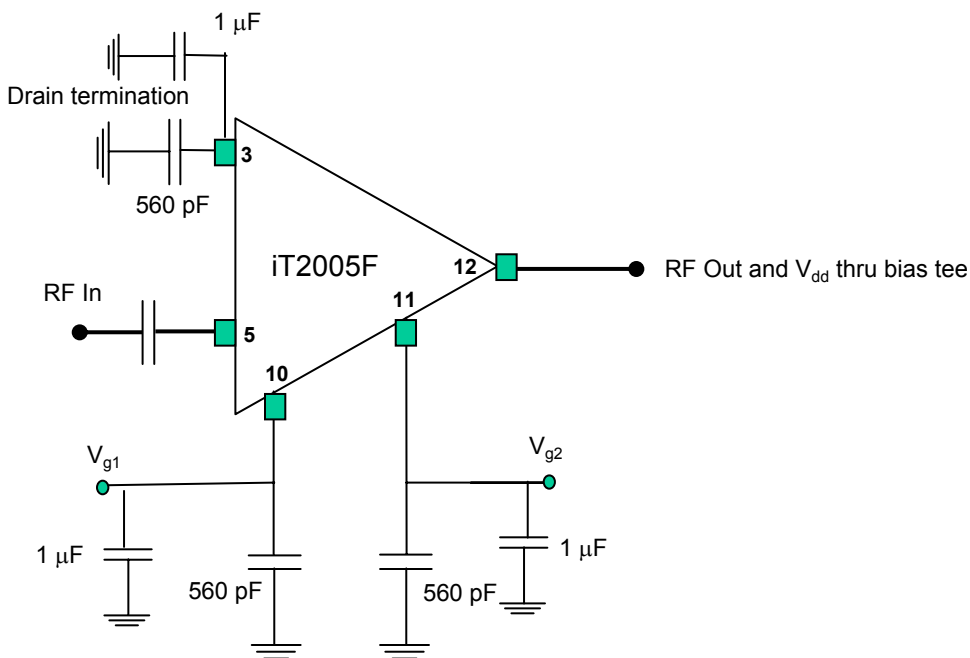

iT2005F

30 kHz to 18 GHz Power Amplifier

Performance Data

At 25° C

P1dB, Vdd=8V, Idd=220mA

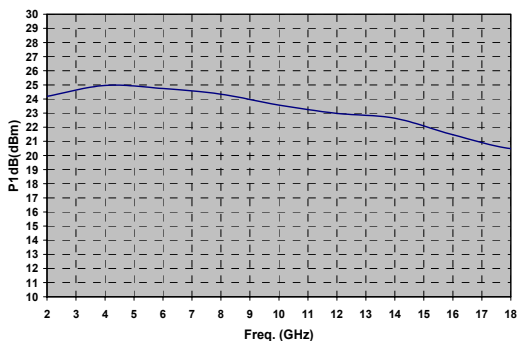

Psat, Vdd=8V, Idd=220mA

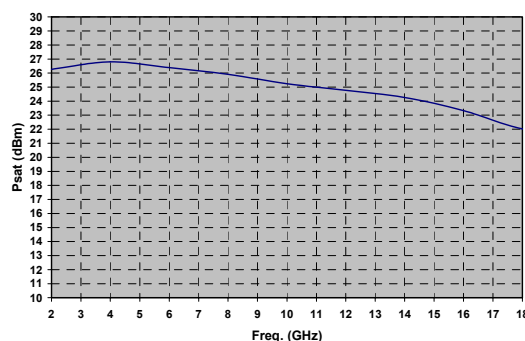

iT2005F Gain
Vdd=8V, Idd=220 mA

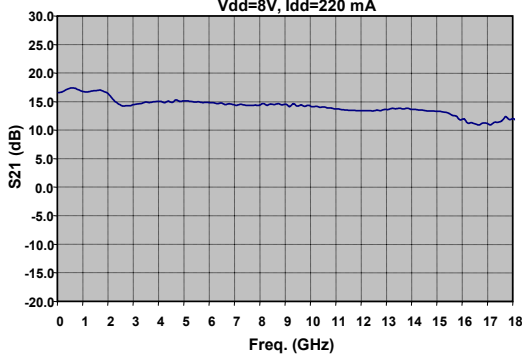

iT2005F Input Return Loss
Vdd=8V, Idd=220mA

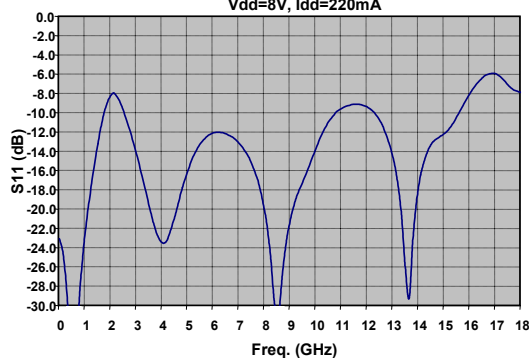

iT2005F Output Return Loss,
Vdd=8V, Idd=220mA

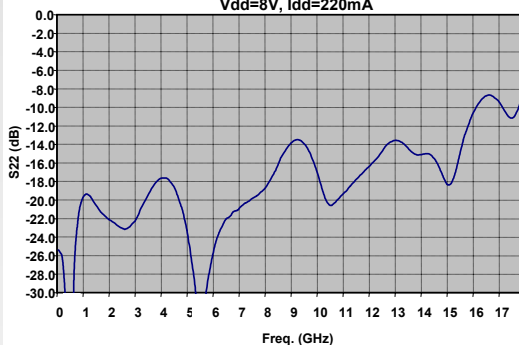

iT2005F Isolation,
Vdd=8V, Idd=220mA

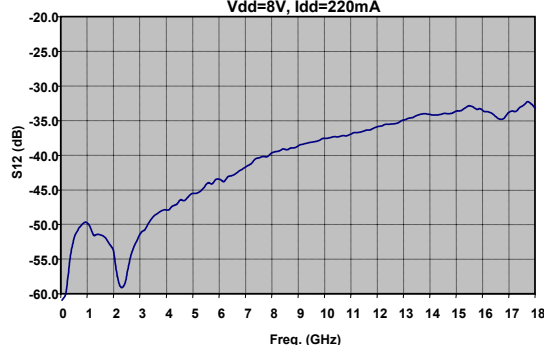

iT2005F

30 kHz to 18 GHz Power Amplifier

“F” Package Drawing, Pinouts, and Marking

Notes:

Dimensions in inches (mm)
Tolerances are ± 0.0039 in.
(0.100 mm)

Package drawing encompasses JEDEC MO-220 Version VHHC-2

See iTerra Application Note 10 for recommended pad layout. RoHS parts are backward compatible if application note pad layout is followed.

Lead frame material is copper alloy

Mold compound is UL94V0 compliant

Lead finish is NiPdAu

Marking Information
iTerra
MMMMFA
XXNNNN
LLYYWW

Where
MMMM = part number
F = Package Type
A = Temp. Range
XX = Wafer Lot
NNNN=Ser. No.
LLYYWW = MFG D/C

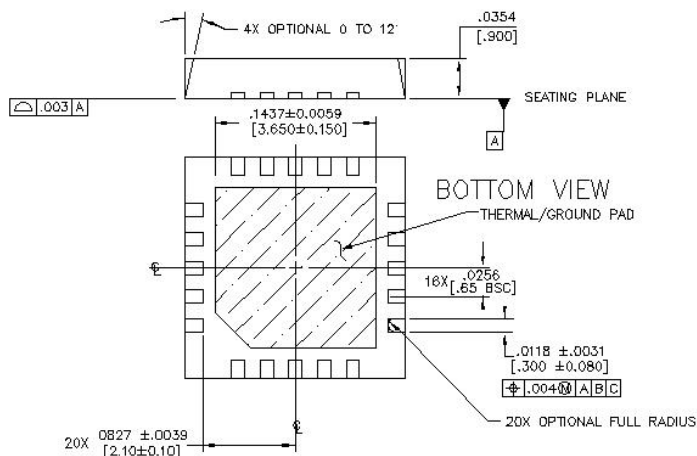
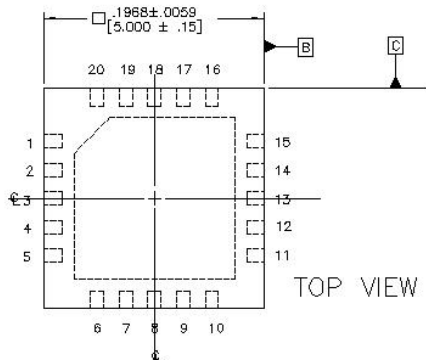

Pinouts

| | |
|-----------------|-------------------|
| P1: N/C | P11: Vg2 |
| P2: N/C | P12: RF Out & Vdd |
| P3: Drain Term. | P13: N/C |
| P4: N/C | P14: N/C |
| P5: RF IN | P15: N/C |
| P6: N/C | P16: N/C |
| P7: N/C | P17: N/C |
| P8: N/C | P18: N/C |
| P9: N/C | P19: N/C |
| P10: Vg1 | P20: N/C |



iT2005F

30 kHz to 18 GHz Power Amplifier

Evaluation
Board

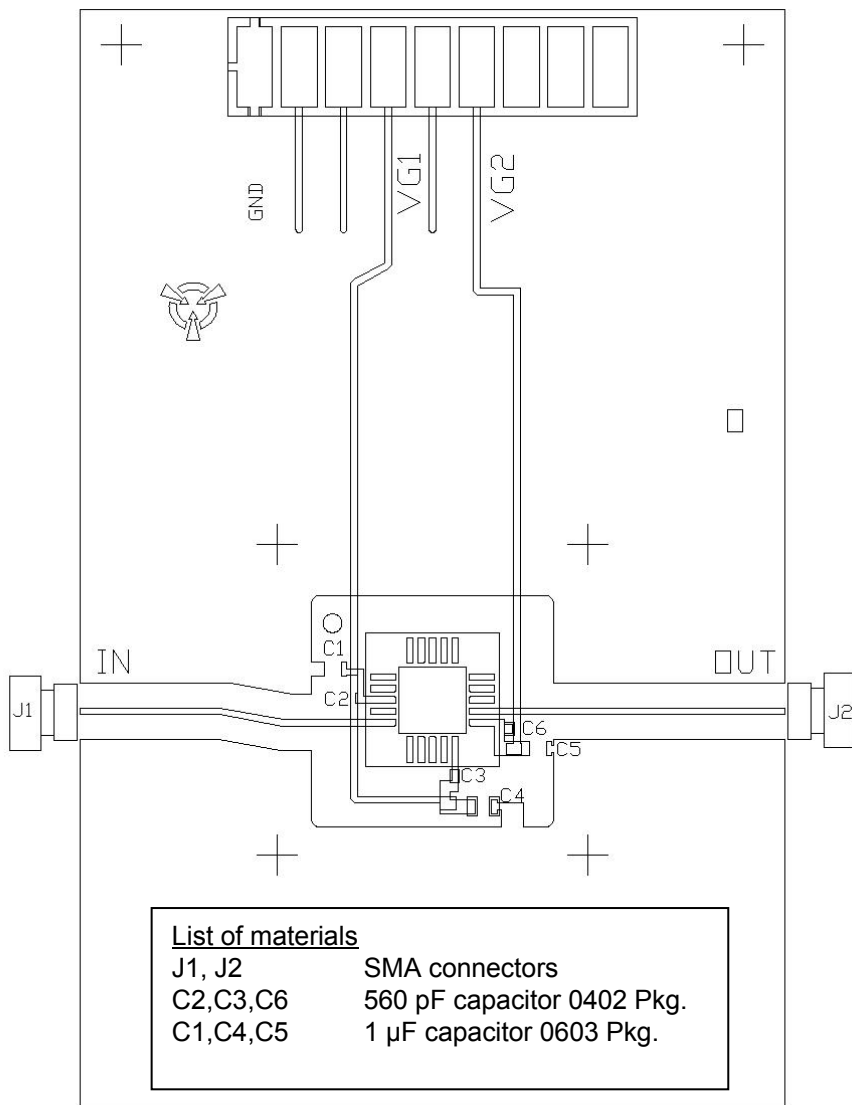

For the RF input/output pads, it is very important to maintain a 50-ohm impedance to guarantee good matching with the package transition and achieve good overall signal integrity. For the C2, C3, and C6 capacitances, the PCB pads must be as close as possible to the package in order to minimize parasitics. The PCB layout shown in the figure minimizes parasitics and allows for package placement by automated assembly equipment. The evaluation board shown is available upon request.



Recommended Procedure for Biasing and Operation

CAUTION: LOSS OF GATE VOLTAGE (V_{GG1}) WHILE CORRESPONDING DRAIN VOLTAGE (V_{DD}) IS PRESENT CAN DAMAGE THE AMPLIFIER.

The following procedure must be employed to properly test the amplifier.

The iT2005F amplifier is biased with a positive drain supply (V_{DD}) and one negative gate supply (V_{GG1}).

The positive power supply is applied through an external bias tee to the RF output.

The recommended bias conditions for the iT2005F is $V_{DD} = 8.0$ V, $I_{DD} = 220$ mA. To achieve this drain current level, V_{GG1} is typically biased between -0.5 V and -0.9 V.

The gate voltage (V_{GG1}) **MUST** be applied prior to the drain voltage (V_{DD}) during power up and removed after the drain voltage is removed during the power down.

For the second gate V_{GG2} a voltage in the range of 3.4 V is required ($V_{DD} = 8$ V, $V_{GG1} = -0.6$ V).

In general $V_{GG2} = V_{DD}/2 - |V_{G1}|$. For example, when $V_{DD} = 8$ V and $V_{GG1} = -0.6$, the recommended voltage operation is: $V_{GG2} = (8 \text{ V}/2) - 0.6 \text{ V} = 3.4$ V. Bias V_{DD} should be applied before or at the same time of V_{GG2} .

