

GLASS PASSIVATED BRIDGE RECTIFIERS

REVERSE VOLTAGE - 50 to 1000Volts
FORWARD CURRENT - 10.0 Amperes

FEATURES

- Surge overload rating -200 amperes peak
- Low forward voltage drop
- Small size; simple installation
- Silver plated copper leads
- Mounting position: Any

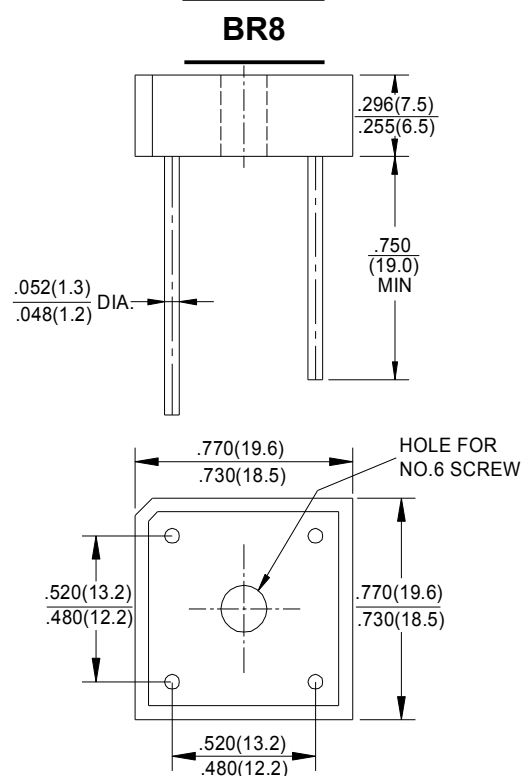

Polarity shown on side of case, Positive lead by beveled corner.
Dimensions in inches and (milimeters)

MAXIMUM RATINGS AND ELECTRICAL CHARACTERISTICS

Rating at 25°C ambient temperature unless otherwise specified.

Single phase, half wave ,60Hz, resistive or inductive load.

For capacitive load, derate current by 20%

CHARACTERISTICS	SYMBOL	BR 10005SG	BR 1001SG	BR 1002SG	BR 1004SG	BR 1006SG	BR 1008SG	BR 1010SG	UNIT
Maximum Recurrent Peak Reverse Voltage	V _{RRM}	50	100	200	400	600	800	1000	v
Maximum RMS Bridge Input Voltage	V _{RMS}	35	70	140	280	420	560	700	v
Maximum Average Forward Rectified Output Current at T _A =50°C	I _(AV)	10.0							A
Peak Forward Surge Current 8.3ms Single Half Sine-Wave Super Imposed on Rated Load	I _{FSM}	175							A
Maximum Forward Voltage Drop Per Bridge Element at 5.0A Peak	V _F	1.1							V
Maximum Reverse Current at Rated DC Blocking Voltage Per Element T _J =25°C T _J =100°C	I _R	10.0 1.0							μA mA
Operating Temperature Range	T _J	-55 to +150							°C
Storage Temperature Range	T _{STG}	-55 to +150							°C

- Notes: 1. Unit mounted on metal chassis
2. Unit mounted on P.C. board

FIG.1-DERATING CURVE
OUTPUT RECTIFIED CURRENT

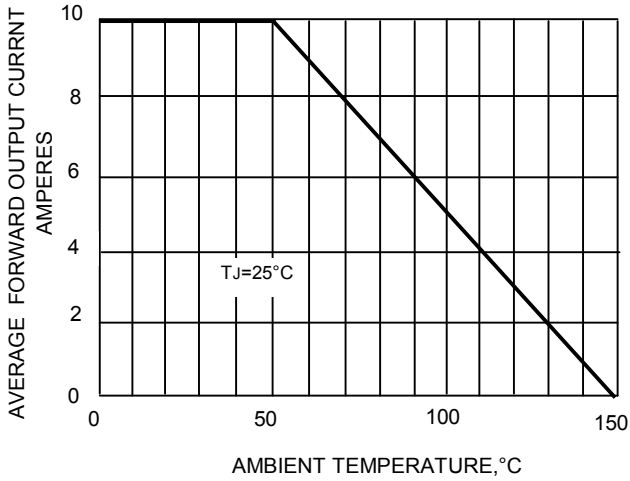

FIG.2-MAXIMUM FORWARD SURGE CURRENT

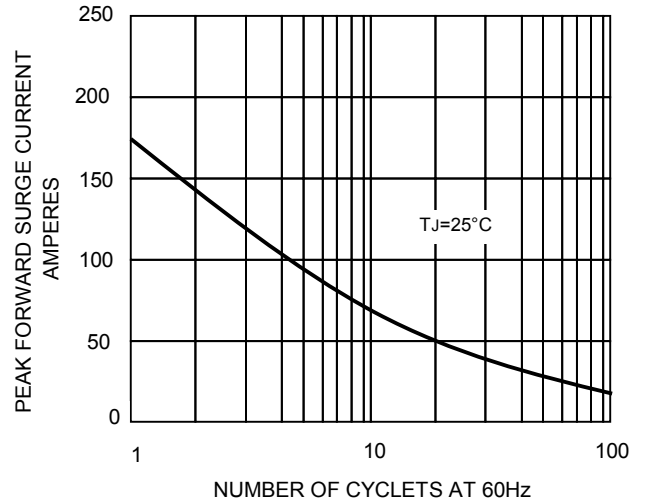

FIG.3-TYPICAL FORWARD CHARACTERISTICS

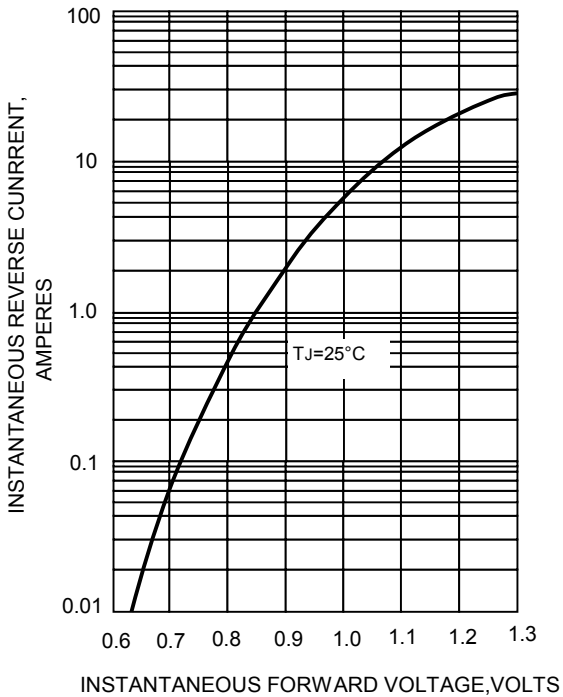

FIG.4-TYPICAL REVERSE CHARACTERISTICS

