

# ITC127 MC68HC705MC4 MOTION CONTROL DEVELOPMENT BOARD

by Bill Lucas and Warren Schultz

## 1 Introduction

In motion control systems microprocessors are used to generate pulse-width modulated (PWM) output signals. It is highly wasteful of computational resources for PWM to be software-generated at inaudible frequencies. A dedicated hardware module, such as the one found on the MC68HC705MC4 is a much more efficient way of producing pulse-width modulation. A systems development board for motion control that uses the MC68HC705MC4's pulse-width modulator is presented here. It is designed to provide control signals for driving brush or three-phase brushless dc motors, and to interface directly with ITC122 and ITC132 power output stages.

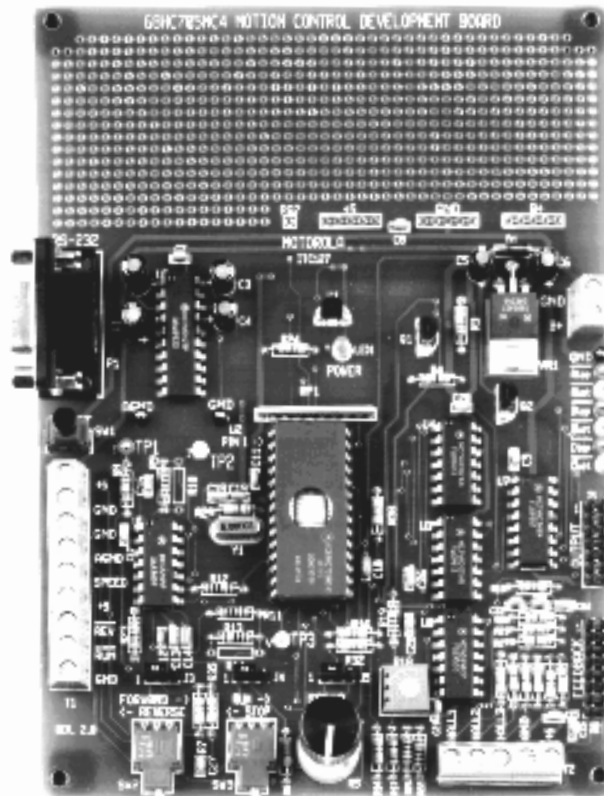

Figure 1 ITC127 Development Board

## 2 Evaluation Board Description

The evaluation board shown in **Figure 1** is designed to provide control signals for brush and brushless dc motors. It accepts inputs from switches and a potentiometer on the board or external RUN/STOP, FORWARD/REVERSE, and SPEED inputs. The speed input is a 0 to +5 volt signal with zero volts corresponding to zero speed and +5 volts producing full speed. RUN/STOP and FORWARD/REVERSE are logic inputs, with logic low inputs producing run and reverse outputs. Hall 1, Hall 2, and Hall 3 inputs are also provided for connection to brushless dc motors.

The ITC127 motion control development board is designed to run in two configurations. It operates on its own with the processor supplied. With the processor removed, it connects to an MC68HC05MC4 emulator via M68CBL05A cable and M68TA05MC4P28 target head adapter. For purposes of motion control code development, the emulator may be run on either an MMDS05 or MMEVS05.

The output side of this board connects to an ITC122 or ITC132 power stage via a ribbon cable. Six outputs provide power device control signals for controlling a three-phase brushless dc motor. Brush dc motors can be controlled by using either one or two of the three available phases. All six outputs will sink 25 mA, making them suitable for directly driving opto couplers in isolated gate drives. A switched +5 volts is also provided to serve as the B+ power source for opto coupler input diodes. This voltage is turned off at reset to facilitate orderly power up and power down of the gate drives.

## 3 Electrical Characteristics

The following electrical characteristics apply to operation at 25 degrees Celsius, and unless otherwise specified, B+ = +12 volts.

**Table 1 Electrical Characteristics**

Characteristic	Symbol	Min	Typ	Max	Units
Power Supply Voltage	B+				
— Driving ITC122		7.5		28	Volts
— Driving ITC132		7.5		15	Volts
Power Supply Voltage	+5	4.75		5.25	Volts
Min Logic One Input Voltage	$V_{IH}$		2.7		Volts
Max Logic Zero Input Voltage	$V_{IL}$		2.0		Volts
Quiescent Current	$I_{CC}$			80	mA
SPEED Input	$V_{SPEED}$		20		%/Volt
Buffer Gain					
— Vtemp	$A_{V(Vtemp)}$		-16.9		
— Vbus	$A_{V(Vbus)}$		2		
— Isense	$A_{V(Isense)}$		2		
Output Sink Current				25	mA

The ITC127 Evaluation Board components are described in the following schematic and parts list. A pin-by-pin circuit description follows in **5 Pin-by-Pin Description**.

**Table 2 ITC127 Evaluation Board Parts List**

Designators	Qty.	Description	Manufacturer	Part Number
C1–C6	6	1	Digi-Key	P5268-ND
C7–C12, C15, C17, C20, C25, C27, C28	12	.1	Sprague	1C105Z5U104M050B
C14	1	.001	Sprague	1C105Z5U102M050B
C13, C26	2	.01	Sprague	1C105Z5U103M050B
C16, C18, C19	3	22 pf Capacitor	Mepco-Centralab	CN15A220K
C21–C24	4	470 pf Capacitor	Sprague	1C105Z5U471M050B
D1	1	General-Purpose Diode	Motorola	1N4002
J1	1	2x7 .1o.c. Jumper Block	Digi-Key	S2011-36-ND
J2	1	2x8 .1o.c. Jumper Block	Digi-Key	S2011-36-ND
J3, J4, J5	3	1x3 .1o.c. Jumper Block	Digi-Key	S1011-36-ND
LED1	1	Green LED	General Instruments	MV5474C
P1	1	DB-9 Connector (Female)	Digi-Key	A2100-ND
Q1	1	Small Signal FET Transistor	Motorola	2N7000
Q2	1	Small Signal PNP Transistor	Motorola	MPSA56
RP1	1	10k Ohm 10 Pin SIP	Digi-Key	770-101R10K-ND
R5	1	5k Ohm Variable Resistor	Clarostat	392JB-5k
R26–R31	6	24 Ohm Resistor	Yageo	
R33	1	47 Ohm Resistor	Yageo	
R18	1	100 Ohm Trim-Pot	Digi-Key	3386P-101-ND
R24	1	470 Ohm Resistor	Yageo	
R2	1	10 Meg Ohm Resistor	Yageo	
R1, R4, R20, R25	4	1k Ohm Resistor	Yageo	
R6, R7, R15, R16, R32, R34, R35	7	4.7k Ohm Resistor	Yageo	
R3	1	10k Ohm Resistor	Yageo	
R8	1	16.9k Ohm Resistor 1%	Yageo	
R23	1	1.0k Ohm Resistor 1%	Yageo	
R19	1	1.40k Ohm Resistor 1%	Yageo	
R17	1	174 Ohm Resistor 1%	Yageo	
R9, R11, R12, R13, R21, R22	6	10k Ohm Resistor 1%	Yageo	
SW1	1	SPST Push-Button Switch	NKK	AB15AP-FA
SW2, SW3	2	SPST Toggle Switch	NKK	A12AH
T1	1	9-Screw Terminal Connector	Phoenix Contact	MKDSN 1,5/9-5,08
T2	1	5-Screw Terminal Connector	Phoenix Contact	MKDSN 1,5/5-5,08
T3	1	2-Screw Terminal Connector	Phoenix Contact	MKDSN 1,5/2-5,08
U1	1	Low Voltage Detector	Motorola	MC34064P-5
U2	1	Microprocessor	Motorola	XC68HC705MC4S

**Table 2 ITC127 Evaluation Board Parts List (Continued)**

Designators	Qty.	Description	Manufacturer	Part Number
U3, U4	2	Quad 2-Input NOR Gate	Motorola	MC74HC02N
U5	1	Quad Op-Amp	Motorola	MC33204P
U6	1	RS-232 Driver/Receiver	Motorola	MC145407P
U7	1	Octal Bus Driver	Motorola	MC74HC366N
U8	1	Hex Schmitt Trigger	Motorola	MC14584BCP
VR1	1	Voltage Regulator	Motorola	MC7805ACT
Y1	1	6.0 Mhz (Low-Profile Crystal)	CTS	ATS060SSLV
Socket for U2	1	28-Pin Machined-Pin IC Socket	Digi-Key	AE7228-ND
Test Point GND, GND, AGND	3	Test Point Black	Components Corp.	TP-104-01-00
Test Point Atop, Btop, Ctop, TP1	4	Test Point Red	Components Corp.	TP-104-01-02
Test Point Abot, Bbot, Cbot, TP2, TP3	5	Test Point Yellow	Components Corp.	TP-104-01-04
Screws for P1	2	2-56 x 1/4" screw		
Nuts for P1	2	2-56 nut		
Screw for VR1	1	4-40 x 1/4" screw		
Nut for VR1	1	4-40 nut		
No Designator	1	Insulator for Y1	Bivar	CI-192-028
No Designator	3	Shorting Jumpers for J4-J5	Digi-Key	929955-06-ND
No Designator	4	Self-Stick Rubber Feet		
No Designator	1	Bare Printed Circuit Board		

## 5 Pin-by-Pin Description

Inputs and outputs are grouped into six connectors. Inputs are located on screw connector T1. They are optional external interfaces that include a provision to power the board with +5 volts if the B+ input on connector T3 is not used. Screw connector T2 contains three Hall sensor inputs, a +5 volt connection for the Hall sensors, and a ground. B+, if used instead of the +5 volt input, is supplied through screw connector T3. It will accept power supply voltages from +7.5 to +28 volts when driving an ITC122 power stage, and +7.5 to +15 volts when driving an ITC132. The lower voltage limit for driving the ITC132 results from the need to supply more current from the +5 volt bus to drive opto coupled inputs. Ribbon connector J1 contains six outputs for driving a power stage and a switched +5 volt power line. Feedback signal inputs are located on ribbon connector J2, where there is provision for temperature, bus voltage, and current sense feedback signals. There is also a DB-9 connector with the standard configuration for RS-232. Ribbon connector pinouts are shown in **Figure 2**.

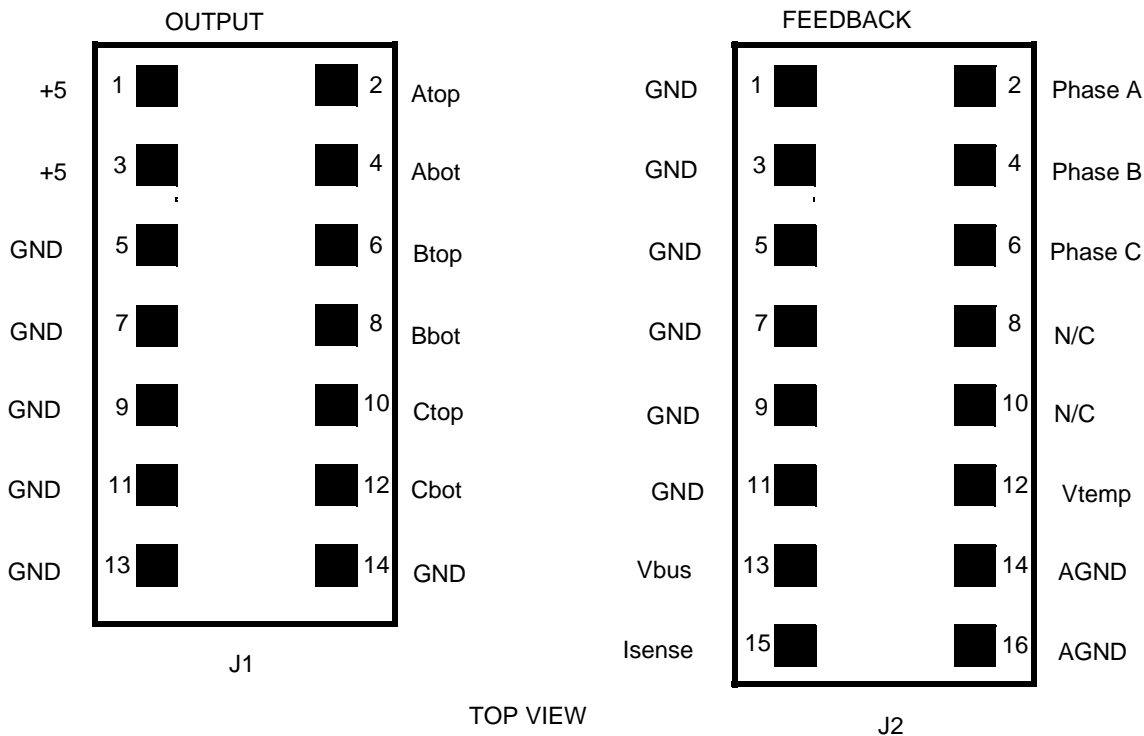

**Figure 2 Ribbon Connector Pinouts**

**5.1 B+ Connector T3**

**5.1.1 B+**

B+ is one of two possible power supply connections. The board requires either a +7.5 to +15 Vdc supply on this input, or a +5 volt supply on connector T1. One or the other, not both, are required. It is located on the screw connector T3.

**5.1.2 GND**

The GND terminal on this connector is intended as the return for power supply B+.

**5.2 Input Connector**

**5.2.1 +5**

This input is an alternate input to B+. If it is used, no connection to B+ is required.

**5.2.2 GND**

There are multiple ground connections. The one adjacent to +5 is intended as the +5 volt return.

**5.2.3 AGND**

An analog ground for the speed control input is labeled AGND.

## 5.2.4 SPEED

This input can be used to control motor speed with an external zero to +5 volt analog signal. Zero volts corresponds to zero speed, and +5 volts to full speed. To use it, jumper J5 needs to be moved to the external position, which disables the on-board speed control potentiometer. As shipped, J5 is set to control speed from the potentiometer.

## 5.2.5 REV

This is an external logic input that reverses the motor when it is grounded. To use it, jumper J3 needs to be moved to the external position, which disables the on-board FORWARD/REVERSE switch. As shipped, J3 is set to control direction from the switch.

## 5.2.6 RUN

This is an external logic input that enables the motor when it is grounded. To use it, jumper J4 needs to be moved to the external position, which disables the on-board RUN/STOP switch. As shipped, J4 is set to control RUN/STOP from the switch.

## 5.3 Hall Connector

### 5.3.1 HALL 1, HALL 2, HALL 3

These inputs are intended to receive open collector Hall sensor outputs from brushless dc motors. They are buffered with Schmitt triggers and filtered for noise immunity.

### 5.3.2 +5

This connection is for the +5 volts that the board supplies to Hall sensors in a brushless dc motor.

### 5.3.3 GND

GND on this connector is the Hall sensor ground.

## 5.4 Feedback Connector

### 5.4.1 Isense

Pin 15 of feedback connector J2 is intended to be a current sense input. It is connected to A/D channel AD1 through a gain of two non-inverting amplifier. The gain of this amplifier has been made easy to adjust by supplying blank pads for optional resistors R14 and R10.

### 5.4.2 Vbus

Pin 13 of connector J2 is connected to A/D channel AD0 through a gain of two non-inverting amplifier. It is intended for motor bus voltage feedback.

### 5.4.3 Vtemp

Pin 12 on connector J2 is connected to an amplifier that is designed to translate the forward voltage of a diode into a usable A/D voltage. The output of this amplifier is connected to A/D channel AD2. Its primary use is temperature sensing.

### 5.4.4 AGND

Pins 14 and 16 are tied to AGND, which is a ground for analog circuits. This ground is routed such that all of the analog returns connect with digital ground at just one point.

## 5.5 Output Connector

### 5.5.1 Switched +5

Pins 1 and 3 are connected to the +5 volt bus through a switch that is open at reset. The resulting switched +5 volts can be used to power opto couplers in isolated off-line motor drives. The off-at-reset feature keeps output transistors off during reset.

### 5.5.2 GND

Pins 5, 7, 9, 11, 13, and 14 are tied to ground. They provide a return for the switched +5 volts and are used to provide noise isolation between output lines in a ribbon cable.

### 5.5.3 $\overline{A_{top}}$ — $\overline{C_{bot}}$

Outputs to drive six power transistors are located on pins 2, 4, 6, 8, 10, and 12. They will drive three phases of half-bridge configured output transistors, and are set up in an active low configuration. Processor outputs are routed through cross coupled NOR gates to provide protection from inadvertent simultaneous turn-on of a top and bottom transistor in one phase. They are also buffered to allow direct drive of opto couplers in isolated off-line motor drives.

## 5.6 DB-9 Connector

The DB-9 connector is set up for RS-232 communication with the MC68HC705MC4. It has standard RS-232 pinouts.

## 5.7 Test Points

### 5.7.1 TP1 — TP3

Test points TP1, TP2, and TP3 provide access to buffered feedback signals for temperature, motor bus current, and motor bus voltage. These voltages are seen by A/D converter inputs AD2, AD1, and AD0. The temperature feedback voltage can be calibrated with potentiometer R18.

### 5.7.2 GND and AGND

These test points are provided to facilitate grounding test instruments.

### 5.7.3 Outputs

All six outputs and a ground are also available as test points. They are connected in parallel with the outputs on ribbon connector J1.

## 6 Application Example

An application example shown in **Figure 3** illustrates system connections to an ITC122 power stage and a brushless dc motor. This arrangement can be run stand-alone, or the ITC127 can be connected to an MMDS05 for code development. The two boards are designed such that the drive and feedback ribbon connectors line up. Ribbon cables are supplied. Once they are plugged in, it is only a matter of connecting power supply, motor, and Hall sensor leads to get a system up and running.

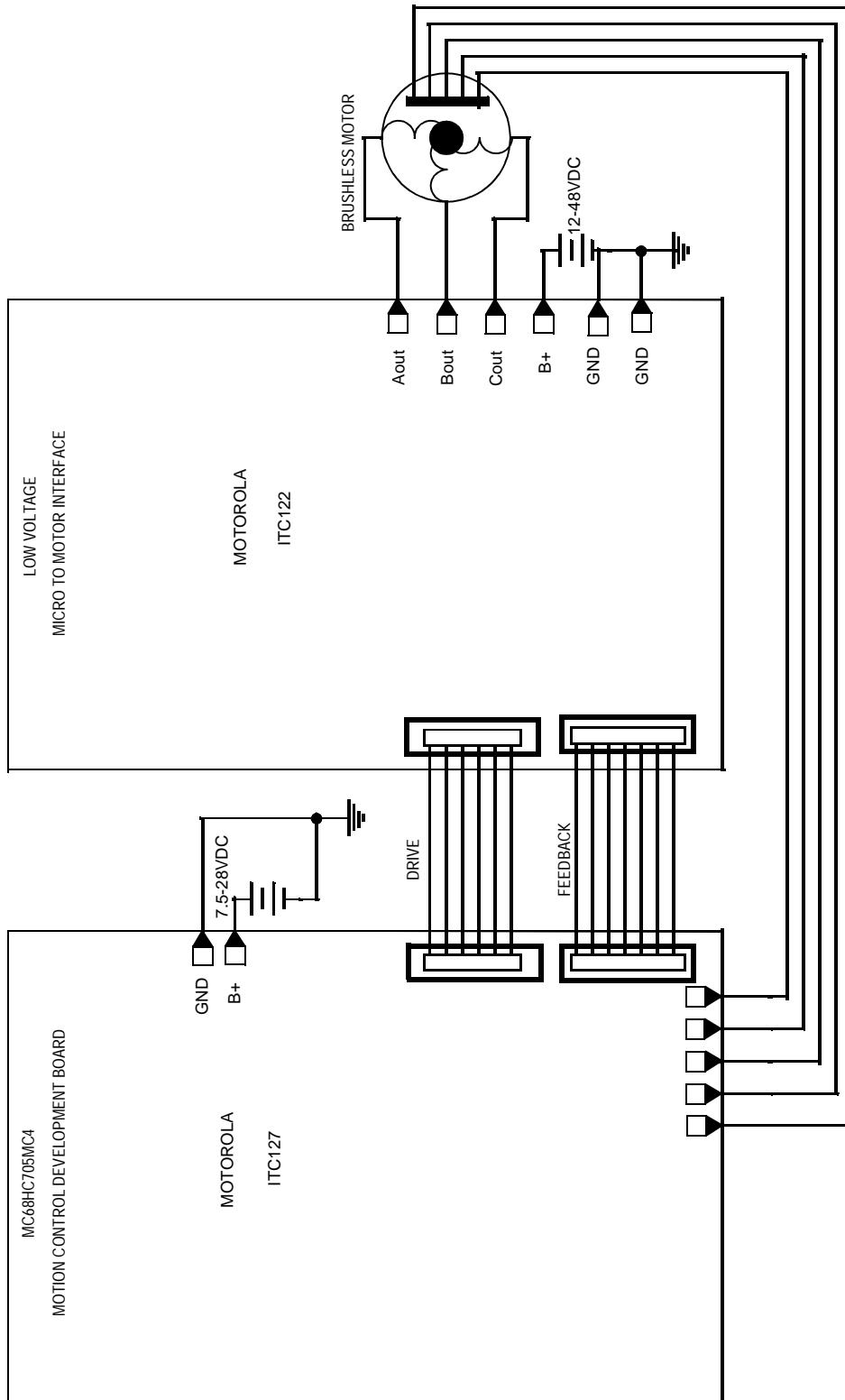

Figure 3 Application Example



The PWM signal is generated by a dedicated PWM generator in the MC68HC705MC4, and can pulse-width modulate the output transistors at a rate of 23 kHz with the processor clocked by a 6.00 MHz crystal. Speed is controlled by the duty cycle of this PWM signal, while direction is determined by commutation sequence. Hall sensor inputs provide commutation feedback from the motor. These sensor inputs are buffered with Schmitt triggers and filtered, to provide noise immunity.

An important application consideration is loss of power. If the two boards in **Figure 3** are powered from separate power supplies, loss of power to the ITC127 board will pull all of the power board's inputs low. With all of its inputs low, the power board will turn on all three upper half-bridge output transistors and abruptly brake the motor. During power down, removal of the ITC127's power before removal of the motor's power supply brakes the motor.

If an ITC132 power stage is used instead of an ITC122, the motor will coast upon removal of the ITC127 control board's power. This difference in behavior occurs because opto inputs on the ITC132 are powered from a switched +5 volts that originates on the ITC127 board.

## 7 Design Considerations

A number of design considerations are important in brushless dc motor drive systems. Sensor inputs, simultaneous conduction lockout, power up, grounding, and opto coupler drive are discussed below.

### 7.1 Sensor Inputs

For brushless motors that use sensor inputs for commutation, noise immunity of the sensor inputs is a key design consideration. Noise on these inputs can be particularly troublesome, since commutating to the wrong state can jerk the motor and increase power dissipation. To facilitate noise robust sensor inputs, Schmitt triggers have been placed between the Hall sensor input connector and ports PA0, PB7, and PB6. Hysteresis makes the Schmitt trigger significantly more robust than using processor ports directly. In addition, these signals are filtered with 100 ns single pole filters. Using relatively low value pull-up resistors, on the order of 1K ohm, provides an additional measure of noise immunity.

Code implementation also has an important influence on noise robustness. Since the sequence of commutation is known, based upon the state of the forward/reverse input, it is relatively easy to detect an out-of-sequence Hall sensor input. Generally speaking, when this occurs it is desirable to turn off all the power transistors until a valid Hall code is received.

### 7.2 Lockout

It is desirable to prevent simultaneous conduction of upper and lower power transistors in the same phase, particularly on a machine that will be used for code development. This is easily accomplished with the cross-coupled NOR gates that are shown in **Figure 4**. These gates lock out the bottom transistor drive signals whenever the top transistor in the same phase is on. Code errors, therefore, will not destroy power stage output transistors by turning on the top and bottom of one half-bridge simultaneously. This arrangement also prevents simultaneous conduction in the event of a noise-induced software runaway.

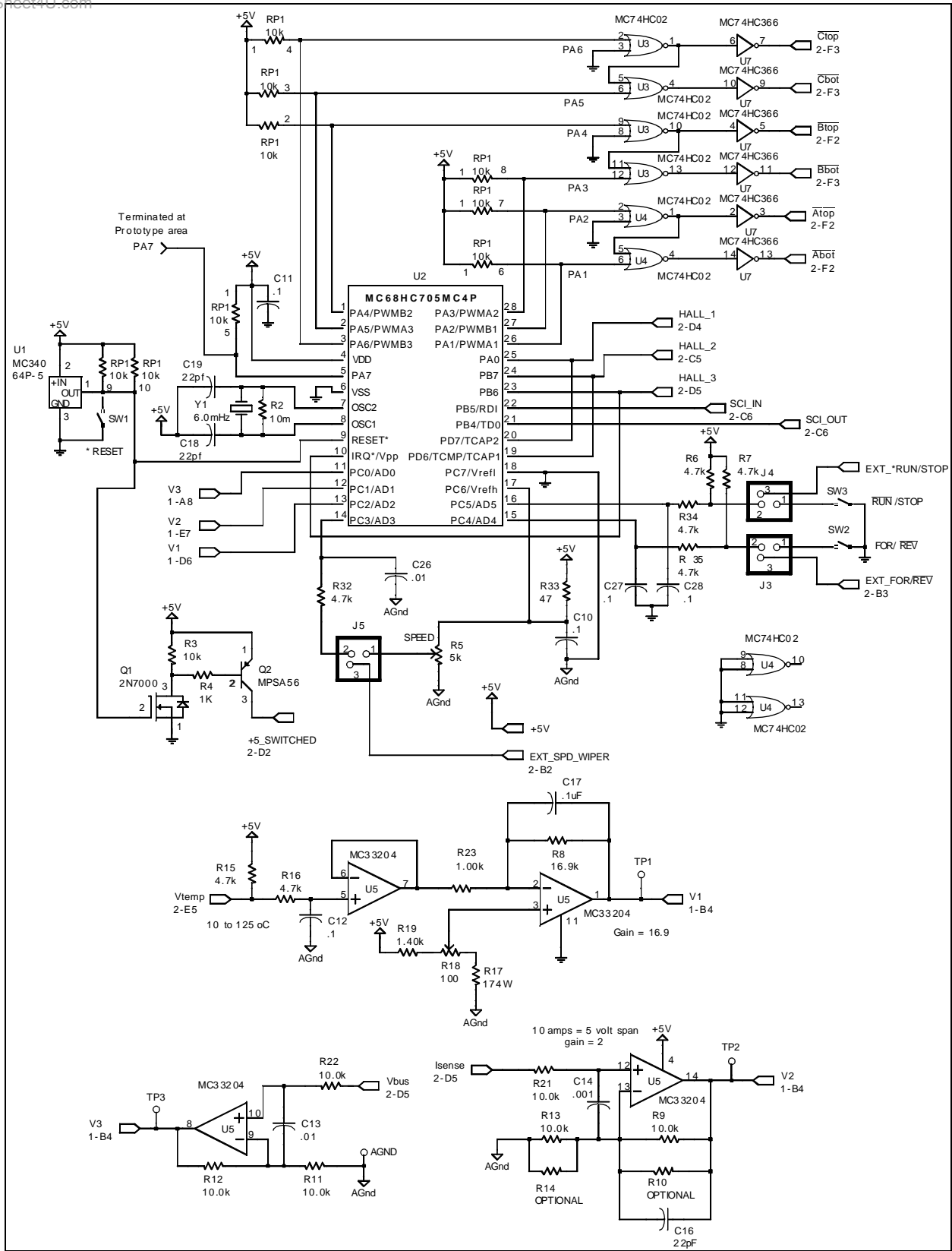

Figure 4 ITC127 Evaluation Board Schematic (Sheet 1 of 2)

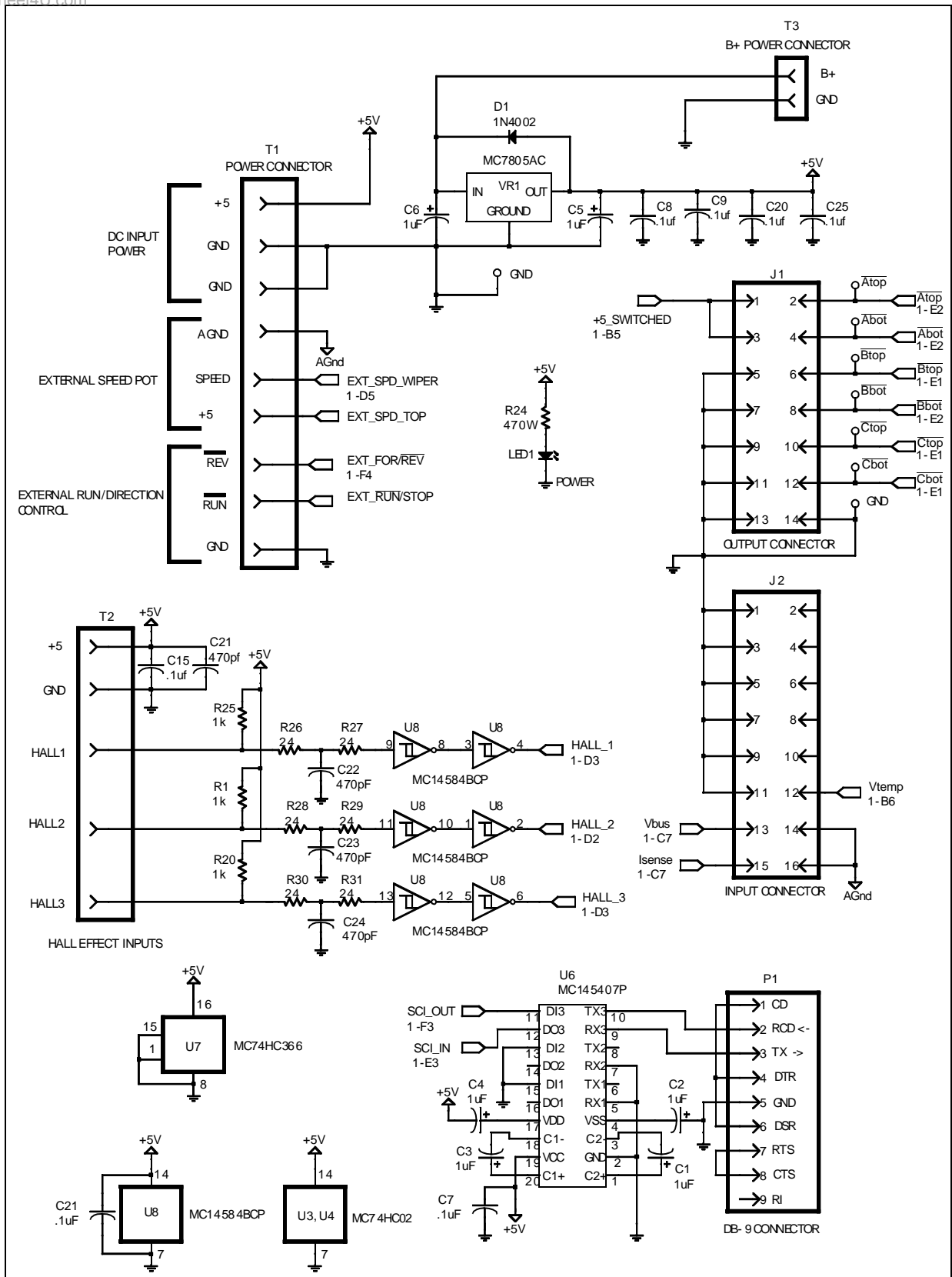

Figure 4 ITC127 Evaluation Board Schematic (Sheet 2 of 2)

### 7.3 Power Up/Power Down

When power is applied or removed it is equally important that top and bottom output transistors in the same phase are not turned on simultaneously. Since the outputs are low when unpowered, sequencing is important in opto coupled drives where the output buffers drive opto couplers. To insure proper sequencing, a switched +5 volts is provided for sourcing drive current to the opto couplers. This supply is held off by an MC34064 until RESET occurs and input voltage is high enough for safe operation. Connection to an opto input is illustrated in **Figure 5**. It applies to operation with an ITC132 power stage.

### 7.4 Grounding

Last but not least, board layout is an important design consideration. In particular, how grounds are tied together influences noise immunity. In order to maximize noise immunity, two grounds are used. Digital ground (GND) is common to the power supply return and serves as a general-purpose ground. An analog ground (AGND) ties the speed control input return, op amp U3's signal grounds, and the A/D converter's  $V_{ref1}$  together before connecting with digital ground at only one point. AGND also runs as a separate trace to pins 14 and 16 of FEEDBACK connector J2.

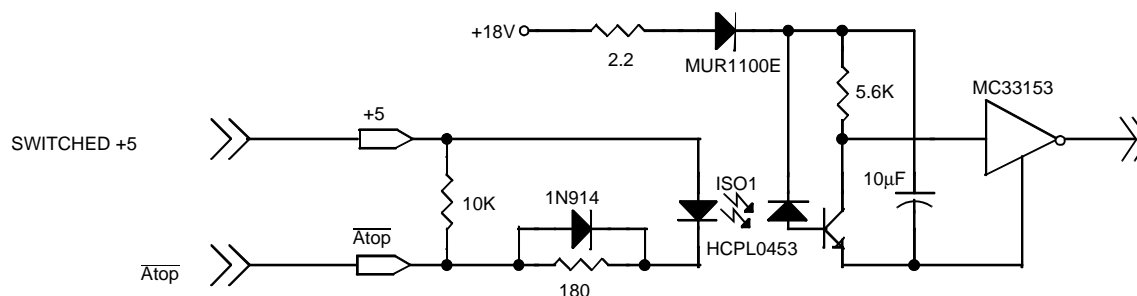

**Figure 5 Connection to an Opto Coupled Output Stage**

## 8 Software

Four software modules and a batch file for assembling them are contained on a 3.5 in. floppy diskette included with the ITC127 motion control development board. Modules A and B contain source code for basic brush and brushless motor control. Modules C and D contain source code for a somewhat "smarter" version of the same software. The brushless modules are written for motors with 60-degree Hall sensors. These files can be assembled with the Motorola "MASM" assembler. Some syntax changes may be necessary for use with assemblers from other vendors.

**Table 3 Sensor Codes**

ANGLE	HALL1	HALL2	HALL3	Aout	Bout	Cout
0	1	0	0	+	—	NC
60	1	1	0	+	NC	—
120	0	1	0	NC	+	—
180	0	1	1	—	+	NC
240	0	0	1	—	NC	+
300	1	0	1	NC	—	+

To assemble the files, consult the WHATSUP.DOC file on the diskette. Note the handling of the MC68HC705MC4's watchdog timer bit in the MOR register when emulating the processor with a MMDS05/MMEVS05 or when using the EPROM device on the ITC127 board. The watchdog must be disabled when the processor is used in a stand-alone mode on the ITC127 board. The MOR register code must be commented out for loading the S-records into the MMDS05/MMEVS05, as location \$F00 is considered to be ROM in the emulator's memory map. The MC68HC705MC4 residing in the emulator must have its watchdog timer bit in the MOR register disabled.

The software shows very basic facilities to commutate and provide basic control for brushless and brush type dc motors using the MC68HC705MC4. Complexity is kept to a minimum so the user will spend minimum time studying the software and understanding the steps required to spin a motor. All of the software modules provide open loop motor control. Closed loop algorithms such as PID can be added to provide better speed control under varying load conditions.

The modules have been developed using ITC127 control boards, connected to ITC122 and ITC132 power stages. Brushless dc motor software modules were verified with fractional horsepower motors from Pittman, Hurst, Astromec, and Kollmorgen. Brush dc motor software modules were tested using an automotive radiator fan motor.

A brief description of each module follows.

### 8.1 SMPLBRLS.ASM

This software module provides basic commutation of a brushless dc motor. There is no acceleration software control provided by the module. An explanation of this software may help.

There are four sources of interrupts to the processor. Each Hall effect rotor position sensor transition provides one of three interrupts. The fourth interrupt is provided by the processor's timer overflow interrupt. The RUN/STOP toggle switch is monitored by the program. When the switch is in the RUN position, the potentiometer is read by the A/D converter and that value is placed into the PWM data register. Because the motor is not rotating, no Hall sensor interrupts are received. Nothing will happen until the timer overflow interrupt has incremented a variable named TIMEOUT to three. When this occurs, the program looks at the position of the rotor and commutates it to its next position in the rotation sequence. As the motor rotates, the Hall effect sensors will then interrupt the processor and commutation will continue. At this point, unless the motor is rotating very slowly, the timer overflow interrupt that helped the motor to start will no longer have an effect on the program, as rotation will keep the values of TIMEOUT to less than three. To keep things simple, this software only rotates the motor in a clockwise direction as viewed from the shaft end of the motor. Speed control is provided by reading the value of the speed potentiometer on the board and placing the potentiometer value in the PWM data register.

### 8.2 BRUSHLES.ASM

This software module provides somewhat more intelligent commutation of a brushless dc motor than SMPLBRLS.ASM. To protect power transistors, PWM limits are checked at the lower and upper ends of the PWM duty cycle. Motor direction control is provided by sensing the position of the FORWARD/REVERSE toggle switch. To help eliminate jerking at initial startup and upon direction changes, a simple form of acceleration control is provided. Hall effect sensor error code checking/recovery is included to enhance noise immunity. In addition, the speed control A/D value is integrated to eliminate jitter at speed extremes. Motor commutation is the same as provided in the SMPLBRLS.ASM software.

### 8.3 SMPLBRSH.ASM

Controlling a brush type dc motor is much easier than driving a brushless dc motor. This software sets up the PWM generator such that Aout will switch B+ voltage to the motor and Cout will be the ground output to the motor. The Aout output will receive the PWM signal. This software module simply reads the RUN/STOP toggle switch and, if it is in the off position, the program will force the PWM duty cycle to zero, thus stopping the motor. If the switch is in the on position, the potentiometer value is read by the A/D converter and that value is placed into the PWM data register, controlling the speed of the motor.

## 8.4 BRUSH.ASM

This software module provides somewhat more intelligent control of a brush dc motor than SMPLBRSH.ASM. Similar to BRUSHLESS.ASM, PWM limits, forward/reverse, and controlled acceleration are provided. Speed control is the same as provided in SMPLBRSH.ASM.

## 9 Conclusion

By combining an M68HC05 core with a motor-specific PWM timer, the MC68HC05MC4 has been made easy to use in brush and brushless dc motor drive applications. The board described here is intended to allow code development without the necessity for building hardware and it interfaces easily with ITC122 and ITC132 power stages.



Motorola reserves the right to make changes without further notice to any products herein. Motorola makes no warranty, representation or guarantee regarding the suitability of its products for any particular purpose, nor does Motorola assume any liability arising out of the application or use of any product or circuit, and specifically disclaims any and all liability, including without limitation consequential or incidental damages. "Typical" parameters which may be provided in Motorola data sheets and/or specifications can and do vary in different applications. All operating parameters, including "Typicals" must be validated for each customer application by customer's technical experts. Motorola does not convey any license under its patent rights nor the rights of others. Motorola products are not designed, intended, or authorized for use as components in systems intended for surgical implant into the body, or other applications intended to support or sustain life, or for any other application in which the failure of the Motorola product could create a situation where personal injury or death may occur. Should Buyer purchase or use Motorola products for any such unintended or unauthorized application, Buyer shall indemnify and hold Motorola and its officers, employees, subsidiaries, affiliates, and distributors harmless against all claims, costs, damages, and expenses, and reasonable attorney fees arising out of, directly or indirectly, any claim of personal injury or death associated with such unintended or unauthorized use, even if such claim alleges that Motorola was negligent regarding the design or manufacture of the part.

MCUinit, MCUasm, MCUdebug, and RTEK are trademarks of Motorola, Inc. MOTOROLA and the Motorola logo are registered trademarks of Motorola, Inc. Motorola, Inc. is an Equal Opportunity/Affirmative Action Employer.

**How to reach us:**

**USA/EUROPE/Locations Not Listed:** Motorola Literature Distribution;

P.O. Box 5405, Denver Colorado 80217. 1-800-441-2447, (303) 675-2140

**Mfax™:** RMFAX0@email.sps.mot.com - TOUCHTONE (602) 244-6609, U.S. and Canada Only 1-800-774-1848

**INTERNET:** <http://Design-NET.com>

**JAPAN:** Nippon Motorola Ltd.; Tatsumi-SPD-JLDC,

6F Seibu-Butsuryu-Center, 3-14-2 Tatsumi Koto-Ku, Tokyo 135, Japan. 81-3-3521-8315

**ASIA PACIFIC:** Motorola Semiconductors H.K. Ltd.; 8B Tai Ping Industrial Park,

51 Ting Kok Road, Tai Po, N.T., Hong Kong. 852-26629298



**MOTOROLA**

