

8301

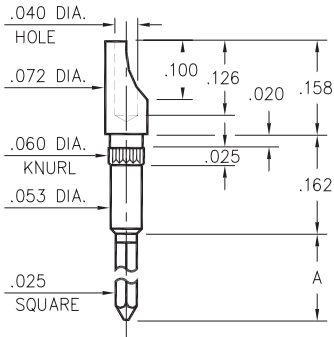

8301-X-24-XX-00-00-01-0
Press-fit in .057 mounting hole

Basic Part Number	# of Wraps	Wrappost Length A
8301-2	2	.370
8301-3	3	.510

1083

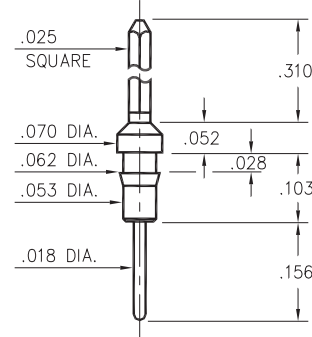

1083-0-05-XX-00-00-01-0
Press-fit in .059 mounting hole

5301

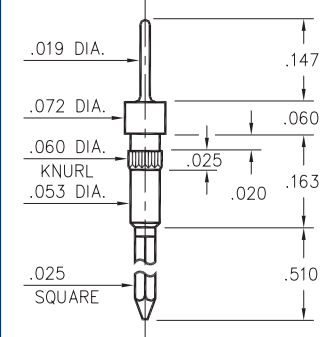

5301-0-05-XX-00-00-01-0
Press-fit in .057 mounting hole

1090

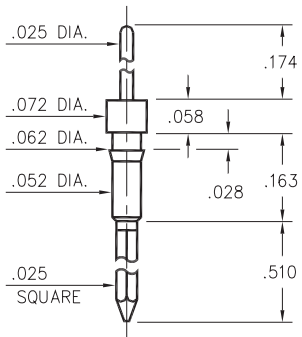

1090-0-05-XX-00-00-01-0
Press-fit in .059 mounting hole

8608

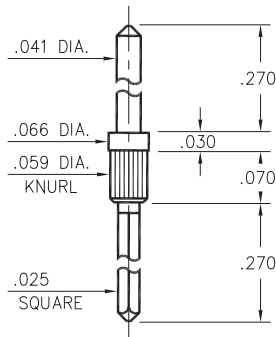

8608-0-05-XX-00-00-01-0
Press-fit in .056 mounting hole

SPECIFICATIONS

PIN MATERIAL:
Brass Alloy 360, 1/2 Hard

DIMENSION IN INCHES
TOLERANCES ON:
LENGTHS: ±.005
DIAMETERS: ±.002
ANGLES: ± 2°

ORDER CODE: XXXX - X - XX - XX - 00 - 00 - 01 - 0

BASIC PART #

SPECIFY PIN FINISH:

- 01 200μ" TIN/LEAD OVER NICKEL
- 80 200μ" TIN OVER NICKEL
- 15 10μ" GOLD OVER NICKEL
- 21 20μ" GOLD OVER NICKEL

