

Standard Timer Connectors
NOTE

All numerical values are in metric units [with U.S. customary units in brackets]. Dimensions are in millimeters [and inches]. Unless otherwise specified, dimensions have a tolerance of ± 0.13 [$\pm .005$] and angles have a tolerance of $\pm 2^\circ$. Figures and illustrations are for identification only and are not drawn to scale.

1. INTRODUCTION

This specification covers the requirements for application of Standard Timer Connectors used with timing mechanisms on washers and other appliances requiring timed operation cycles. The connector consists of a plug housing and Generation I, II, or III Timer Control Terminals.

The housing is available in 2, 4, 7, 10, 18, and 24 positions (or circuits) and is designed with an internal terminal locking lance. The 18- and 24-position housings are color-coded for use in left-hand (white) or right-hand (black) applications. The housings feature locking tabs or latches to help secure mated housings.

The terminals must be terminated using an automatic machine. Each terminal features a locking lance that engages the housing when properly inserted into the terminal cavity. These housings with these terminals mate with housings containing 3.18×0.51 mm [$.125 \times .020$ in.] blade tab receptacle contacts.

When corresponding with Tyco Electronics Personnel, use the terminology provided in this specification to facilitate your inquiries for information. Basic terms and features of this product are provided in Figure 1.

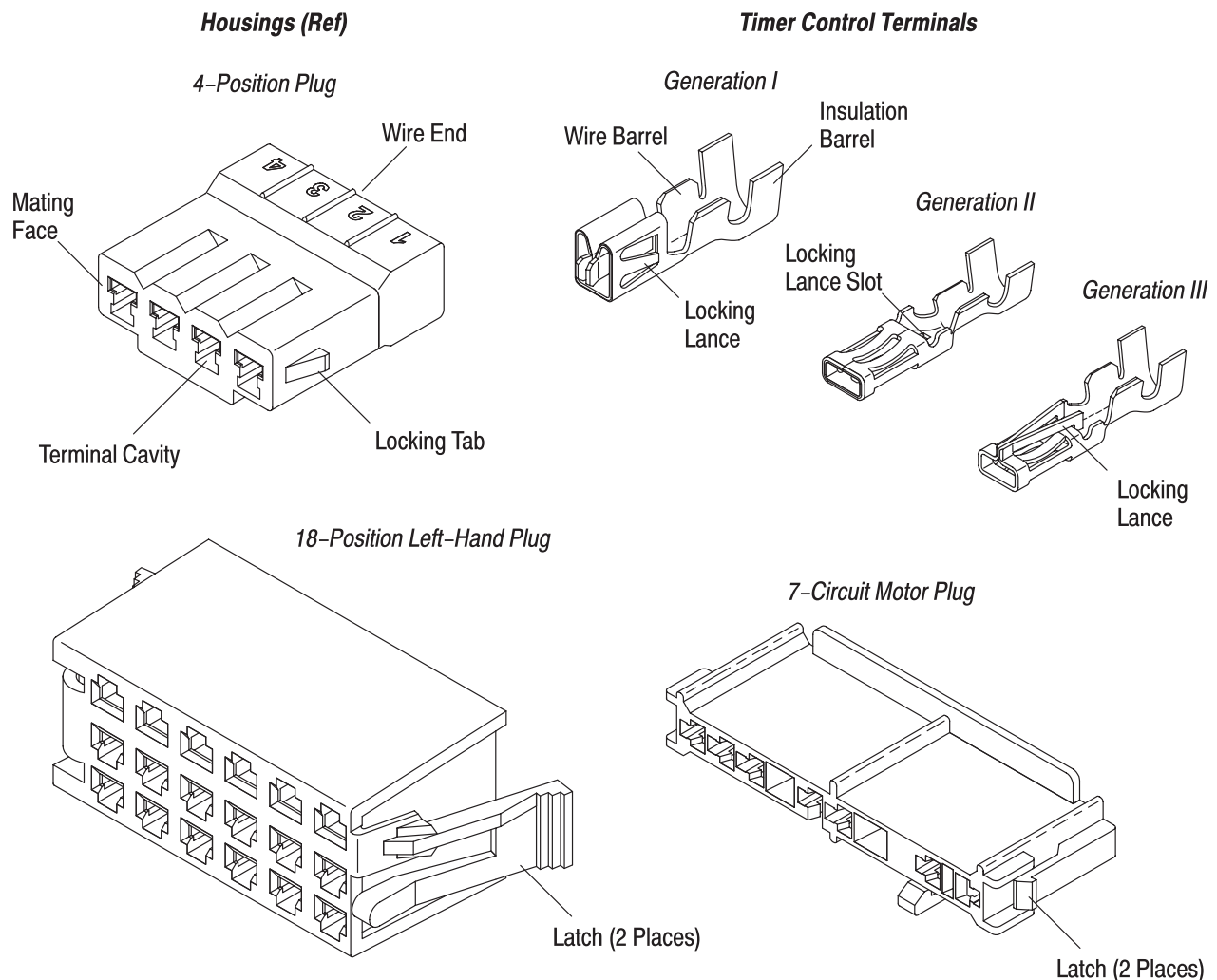

Figure 1

2. REFERENCE MATERIAL

2.1. Revision Summary

Revisions to this application specification include:

- Updated document to corporate requirements
- Added new information to table in Figure 3

2.2. Customer Assistance

Reference Product Base Part Number 521135 and Product Code 1192 are representative of Standard Timer Connectors. Use of these numbers will identify the product line and expedite your inquiries through a service network established to help you obtain product and tooling information. Such information can be obtained through a local Tyco Electronics Representative or, after purchase, by calling PRODUCT INFORMATION at the number at the bottom of page 1.

2.3. Drawings

Customer Drawings for product part numbers are available from the service network. If there is a conflict between the information contained in the Customer Drawings and this specification or with any other technical documentation supplied, the information contained in the Customer Drawings takes priority.

2.4. Specifications

Application Specification 114-2145 provides product description and application requirements for the mating housings containing blade contacts.

Product Specification (108-series) provides product performance and test information. Documents available which pertain to this product are:

108-1067	Timer Connector Terminal
108-1271	Timer Connector with Lanceless .125 Blade Receptacle
108-1271-1	Timer Connector with .125 Blade Receptacle
108-1271-2	Timer Connector with .125 × .020-inch Blade Receptacle

2.5. Instructional Material

Instruction Sheets (408-series) provide product assembly instructions or tooling set-up and operation procedures and Customer Manuals (409-series) provide machine setup and operating procedures. Documents available which pertain to this product are:

408-3295	Preparing Reel of Contacts for Application Tooling
408-7424	Checking Terminal Crimp Height or Gaging Die Closure
408-8040	Heavy Duty Miniature Quick-Change Applicators (Side-Feed Type)
408-9332	Extraction Tool 454983-1
408-9514	Extraction Tool 844751-1
408-9816	Handling of Reeled Products
408-10142	Extraction Tool 1976096-1
409-5128	Basic AMP-O-ELECTRIC* Model "K" Terminating Machine 471273-[]
409-5842	AMP-O-ELECTRIC Model "G" Terminating Machine 354500-[]
409-5852	AMPOMATOR* CLS III-G Lead-Making Machine
409-5878	AMPOMATOR CLS IV+ Lead-Making Machine
409-5884	ADUZI* Lead-Making Machine 662700-[]

3. REQUIREMENTS

3.1. Storage

A. Reeled Terminals

When using reeled terminals, store coil wound reels horizontally and traverse wound reels vertically.

B. Shelf Life

The terminals and housings should remain in the shipping containers until ready for use to prevent deformation or damage to product. The products should be used on a first in, first out basis to avoid storage contamination that could adversely affect connector performance.

C. Chemical Exposure

Do not store product near any chemical listed below as they may cause stress corrosion cracking.

Alkalies	Ammonia	Citrates	Phosphates	Citrates	Sulfur Compounds
Amines	Carbonates	Nitrites	Sulfur Nitrites		Tartrates

D. Ultraviolet Light

Prolonged exposure to ultraviolet light may deteriorate the chemical composition used in the housings.

3.2. Wire Selection and Preparation

The terminals will accept solid or stranded wire sizes 22 through 14 AWG. Proper strip length is necessary to properly insert the wire into the terminal. The strip length of the wire is shown in Figure 2.

CAUTION Reasonable care must be taken not to nick, scrape, or cut any part of the wire during the stripping operation.

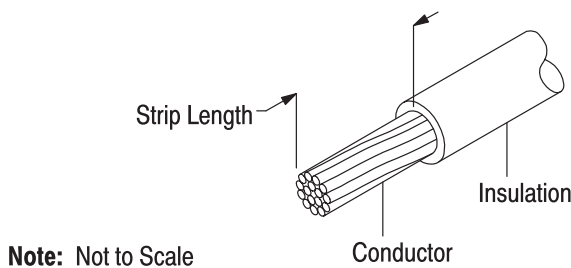
TERMINAL		WIRE			
TYPE	WIRE BARREL WIDTH	SIZE (AWG)	QTY	INSULATION DIAMETER	STRIP LENGTH
Generation I	3.30-2.67 [.130-.105]	20	1	2.16-3.18 [.085-.125]	5.21-4.44 [.205-.175]
		18	1		
		16	1		
		14	1		
		18	2	3.18 [.125] Max	5.46-4.7 [.215-.185]
		16	2		
Generation II and III	3.43-2.54 [.135-.100]	18	1	2.16-3.30 [.085-.130]	4.24-4.50 [.167-.177]
		16	1		
		14	1		
		(1) 16	2	3.12 [.123] Max	5.08-4.32 [.200-.170]
		(1) 18	2	2.84 [.112] Max	
		18	2	2.84 [.112] Max Per Wire	5.08-4.32 [.200-.170]
		20	2		

Figure 2

3.3. Crimp Requirements

The terminal must be terminated according to the instructions included with the appropriate tooling. A terminal as it should appear after crimping is shown in Figure 3.



Wire insulation shall NOT be cut or broken during the crimping operation. Reasonable care should be taken to provide undamaged wire terminations.

A. Crimp Height

The crimp applied to the wire portion of the terminal is the most compressed area and is most critical in ensuring optimum electrical and mechanical performance of the crimped terminal. The crimp height must be within the dimensions provided in Figure 3.

B. Crimp Length

Effective crimp length shall be defined as that portion of the wire barrel, excluding bellmouths, fully formed by the crimping tool. For optimum crimp effectiveness, the crimp must be within the area shown in Figure 3.

C. Bellmouths

Front and rear bellmouths shall be evident and conform to the dimensions given in Figure 3.

D. Cutoff Tab

The cutoff tab shall be cut to the dimensions shown in Figure 3.

E. Burr

The cutoff burr shall not exceed the dimensions shown in Figure 3.

F. Wire Barrel Flash

The wire barrel flash shall not exceed the dimensions shown in Figure 3.

G. Wire Insulation and Conductor Location

After crimping, the wire conductor and insulation must be visible in the transition area between the wire and insulation barrels. The wire insulation shall not be crimped into the terminal wire barrel. The conductor may extend beyond the wire barrel to the maximum shown in Figure 3.

H. Wire Barrel Seam

The wire barrel seam must be closed with no evidence of loose wire strands visible in the seam.

I. Insulation Barrel Seam

The insulation barrel seam must be fully closed with no evidence of insulation visible in the seam.

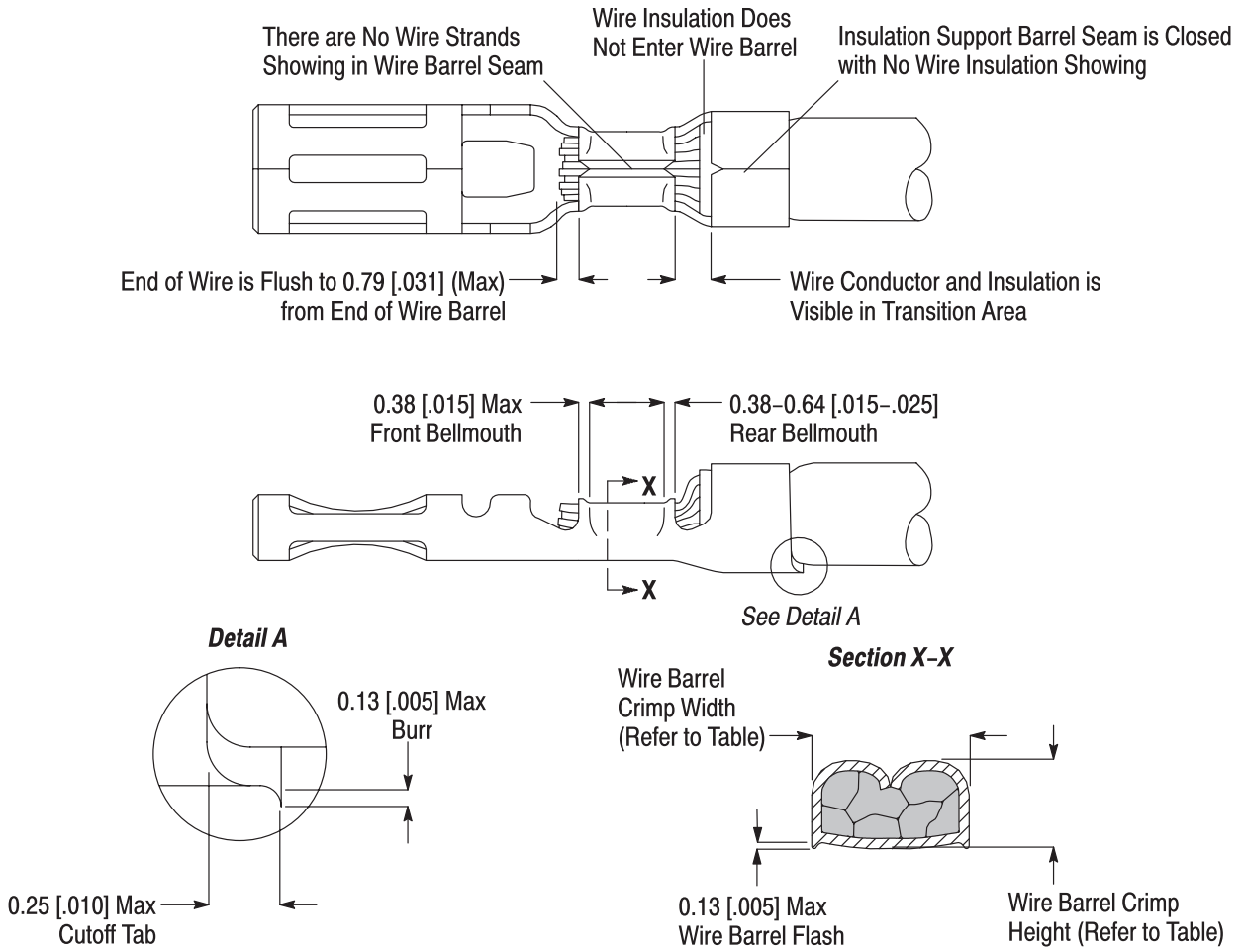

TERMINAL	WIRE SIZE (AWG)	WIRE BARREL CRIMP		INSULATION BARREL CRIMP WIDTH
		HEIGHT	WIDTH	
Generation I	20	1.27-1.37 [.050-.054]	2.29 [.090]	3.56 [.140]
	18	1.37-1.47 [.054-.058]		
	16	1.55-1.65 [.061-.065]		
	14	1.83-1.93 [.072-.076]	2.79 [.110]	
	(2) 18	1.5-1.6 [.059-.063]		
	(2) 16	1.8-1.9 [.071-.075]		
Generation II	18	1.37-1.47 [.054-.058]	2.29 [.090]	3.94-4.19 [.155-.165]
Generation II and III	16	1.52-1.62 [.060-.064]		
	14	1.83-1.93 [.072-.076]		
	(1) 16 (1) 18	1.83-1.93 [.072-.076]		
	(2) 20	1.52-1.62 [.060-.064]		
	(2) 18	1.68-1.78 [.066-.070]		
Generation III	18	1.19-1.30 [.047-.051]	2.29 [.090]	3.94-4.19 [.155-.165]

Figure 3

J. Twist and Roll

There shall be no twist, roll, deformation or other damage to the mating portion of the crimped terminal that will prevent proper mating. See Figure 4.

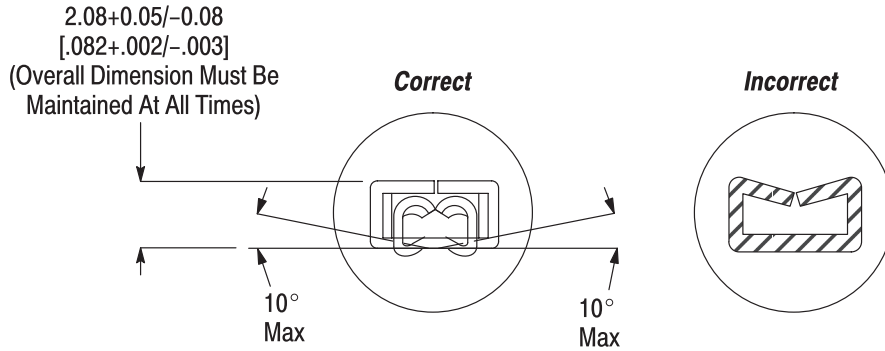

Figure 4

K. Straightness

The force applied during crimping may cause some bending between the crimped wire barrel and the mating portion of the terminal. Such deformation is acceptable within the following limits.

1. Up-and-down — the crimped terminal, including cutoff tab and burr, shall not be bent above or below the datum line any more than the amount shown in Figure 5.
2. Side-to-side — the side-to-side bending of the crimped terminal may not exceed the limits provided in Figure 5.



Periodic inspections must be made to ensure crimped terminal formation is consistent.

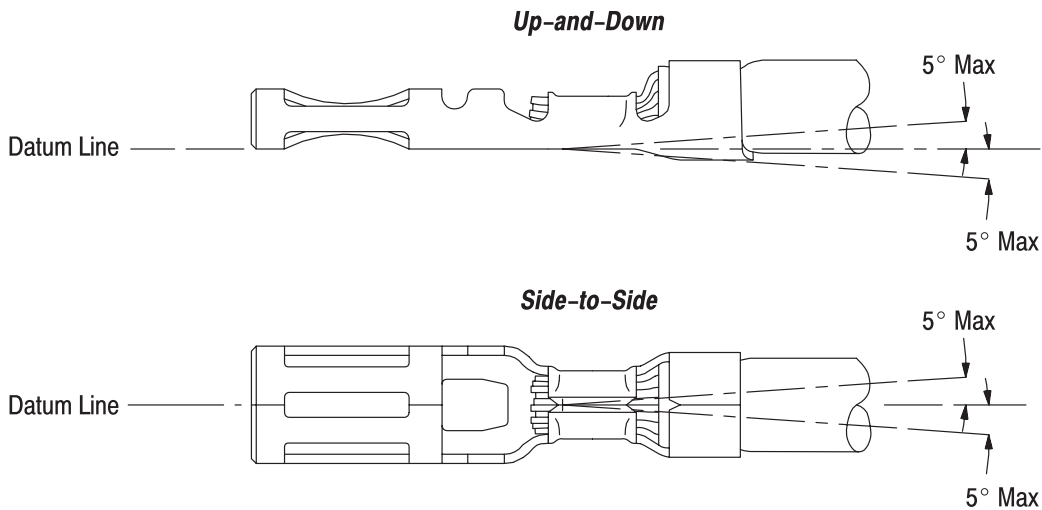

Note: Angles are drawn for clarification only and are not to scale.

Figure 5

3.4. Assembly

The terminal must be aligned with the applicable terminal cavity at the wire end (back) of housing with the locking feature facing the locking feature slot of the terminal cavity. The terminal must be inserted into the terminal cavity until there is an audible “snap.” The terminal must engage the housing. Refer to Figure 6.

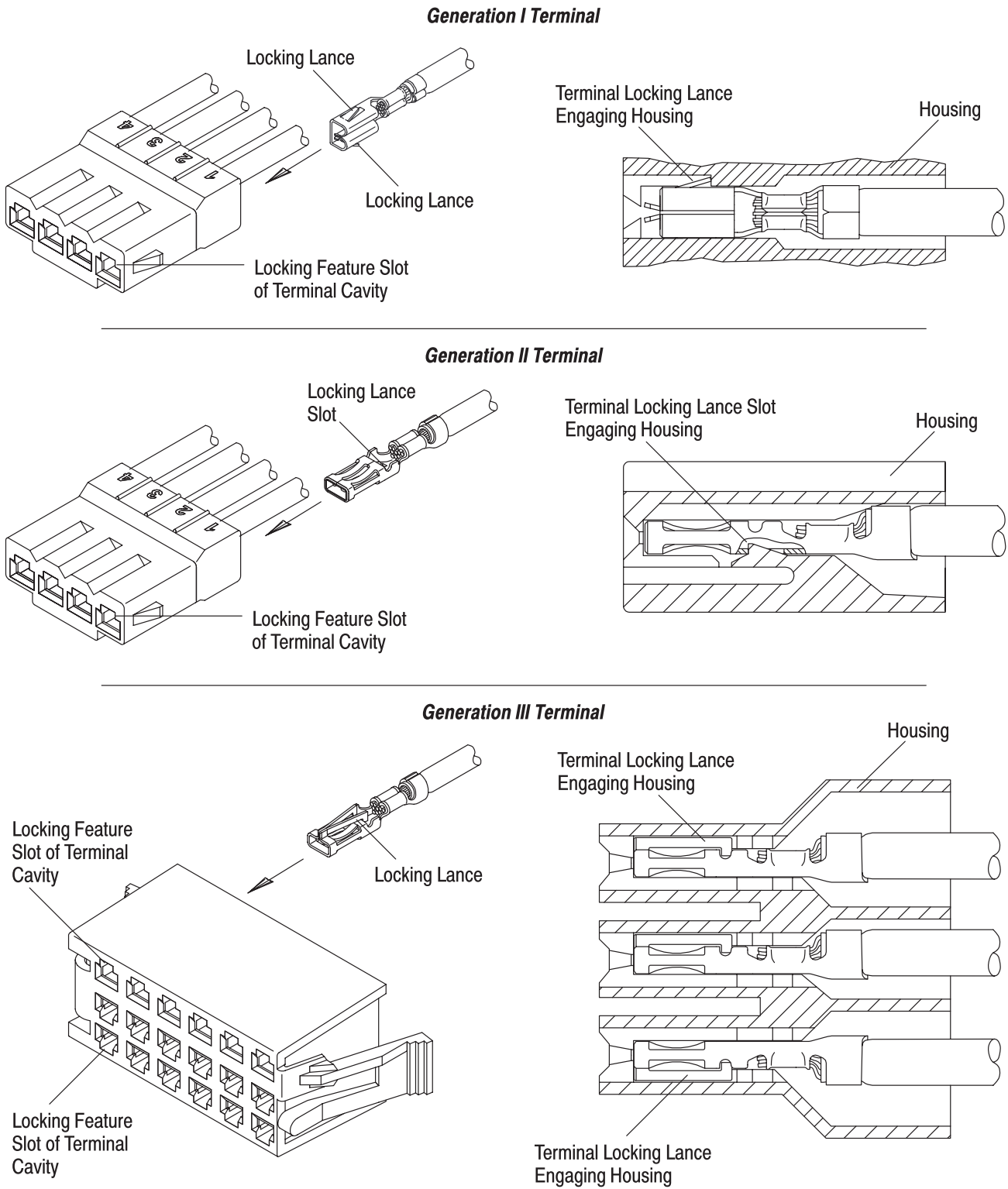

Figure 6

3.5. Repair and Replacement

Terminals are not repairable once a termination has been made. Any damaged or defective terminals must be removed and replaced. Terminals can be removed from the housing using available tooling.



Damaged product should not be used. If a damaged terminal is evident before it is inserted into the housing, the wire can be cut in back of the terminal and the wire end can be re-terminated. If a terminal or housing is damaged after insertion, the wire must be cut directly in back of the housing and re-terminated.

4. QUALIFICATIONS

Standard Timer Connectors are Listed by Underwriters Laboratories Inc. (UL) in File E28476 and Certified by CSA International in File LR 7189.

5. TOOLING

Tooling part numbers and instructional material packaged with the tooling are shown in Figure 7.



Machines have been designed for a variety of application requirements. For assistance in setting up prototype and production line equipment, contact your local Representative or call the TOOLING ASSISTANCE CENTER at the number at the bottom of page 1.

5.1. Applicator

The applicators are designed to crimp strip-fed terminals onto pre-stripped wire. These applicators accept interchangeable crimping dies and must be installed onto a power unit.

5.2. Power Unit

These semi-automatic machines provide the force required to drive the applicator for crimping tape-mounted terminals. These machines are designed to be bench mounted and provide for medium-volume applications.

5.3. Extraction Tool

The extraction tool is designed to remove a terminal from the housing by releasing the locking lance from the housing without damaging the housing or over-stressing the terminal.

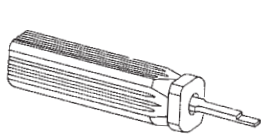

Extraction Tool 454983-1
(408-9332)
(For Generation I Terminal)

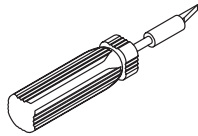

Extraction Tool 844751-1
(408-9514)
(For Generation II Terminal)

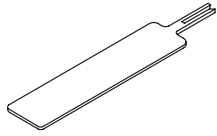

Extraction Tool 1976096-1
(408-10142)
(For Generation III Terminal)

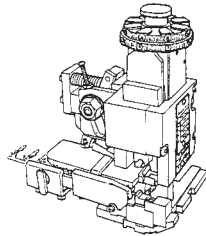

AMP-O-LECTRIC Model "K"
Terminating Machine
471273-[] (409-5128)

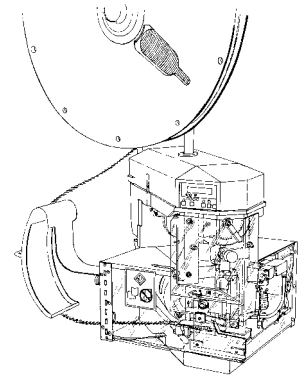

AMP-O-LECTRIC Model "G"
Terminating Machine
354500-1 and -2 (409-5842)

Heavy Duty Miniature Quick-Change
Applicators (Side-Feed Type)
(Refer to Table) (408-8040)

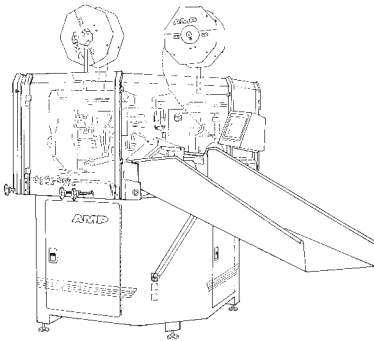

AMPOMATOR CLS III-G
Lead-Making Machine
122500-2 and -3 (409-5852)

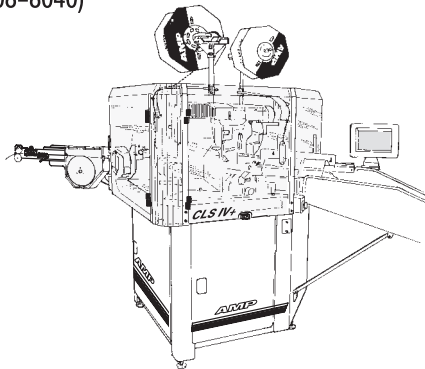

AMPOMATOR CLS IV+
Lead-Making Machine
356500-1 and -2 (409-5878)

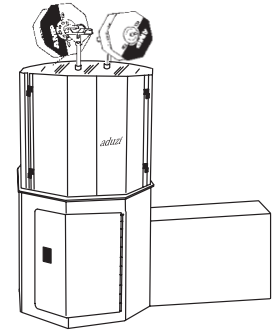

ADUZI Lead-Making
Machine 662700-[]
(409-5884)

WIRE		APPLICATOR	POWER UNIT	
SIZE (AWG)	INSULATION DIAMETER		PART NUMBER	DESCRIPTION
22-18	1.90-3.30 [.075-.130]	680416-1	122500-2, -3, 356500-1, -2, or 662700-[]	Lead-Making
		680416-2	471273-[]	Model "K"
		680416-3	354500-1 or -2	Model "G"
20-14	2.16-3.18 [.085-.125]	466498-1	122500-2, -3, 356500-1, -2, or 662700-[]	Lead-Making
		466498-2	471273-[]	Model "K"
(2) 18 or (2) 16	(2) 3.18 [.125] Max	466603-2	471273-[]	Model "K"
18-14	3.18 [.125] or (2) 2.79 [.110] Max	567349-4	122500-2, -3, 356500-1, -2, or 662700-[]	Lead-Making
		567349-5	471273-[]	Model "K"
	3.18 [.125] Max	567349-9	354500-1 or -2	Model "G"

Figure 7

6. VISUAL AID

Figure 8 shows a typical application of Standard Timer Connectors. This illustration should be used by production personnel to ensure a correctly applied product. Applications which DO NOT appear correct should be inspected using the information in the preceding pages of this specification and in the instructional material shipped with the product or tooling.

CRIMPED TERMINAL

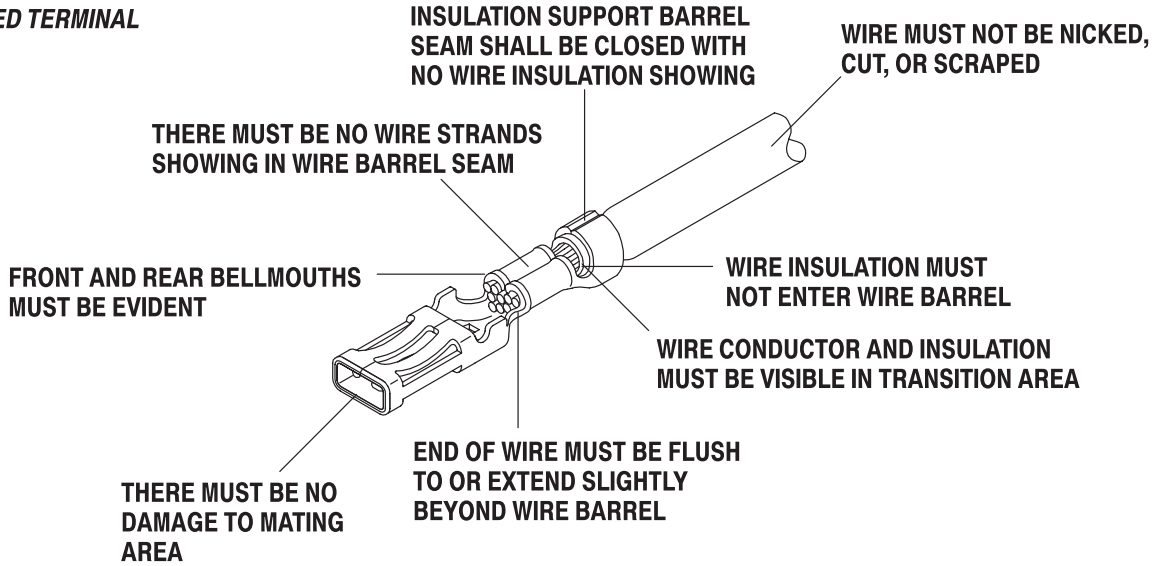

TERMINALS INSTALLED IN HOUSING

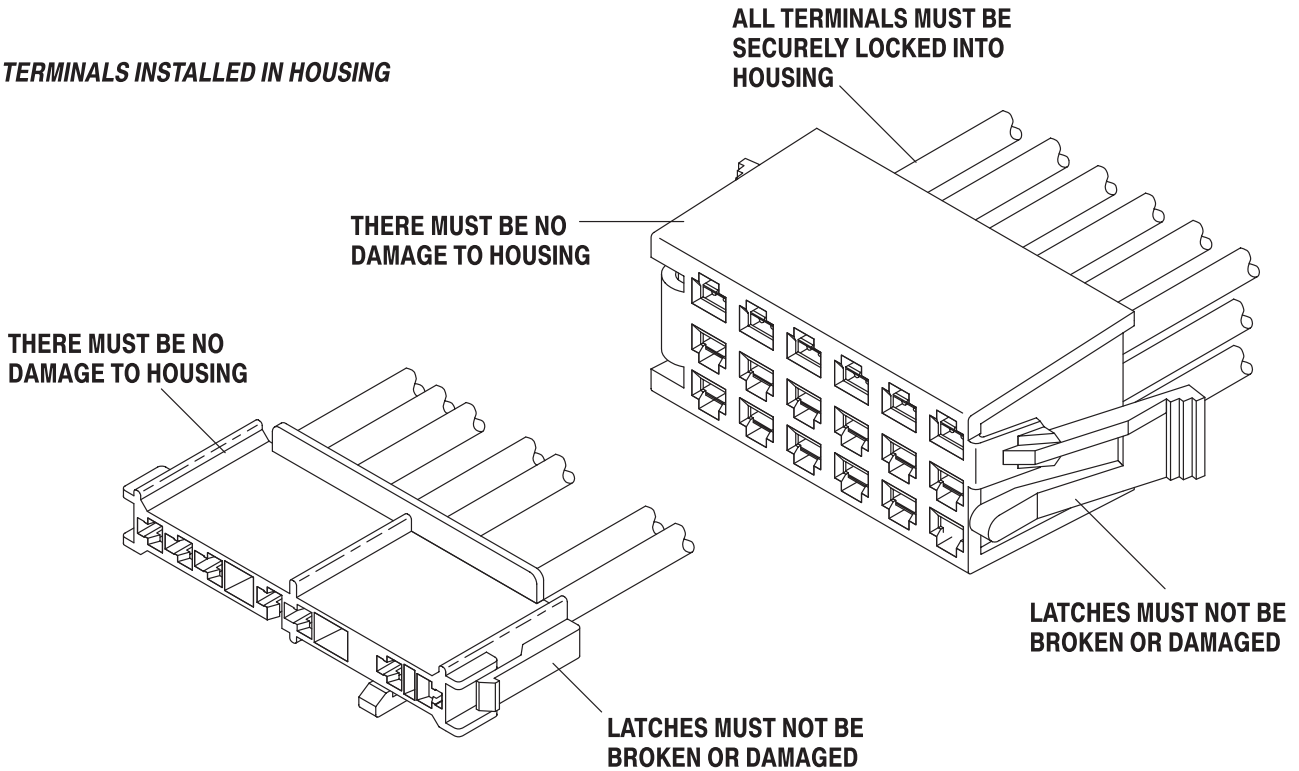

FIGURE 8. VISUAL AID