

GM432

Adjustable Shunt Regulator

Description

The GM432 series are three-terminal adjustable precision shunt regulators with guaranteed stable temperature over the applicable extended commercial temperature range. The output voltage may be set at any level greater than 1.24V (V_{REF}) up to 20V merely by selecting two external resistors that act as a voltage divider network. These devices have a typical output impedance of 0.2Ω. Active output circuitry provides very sharp turn-on characteristics, making these devices excellent improved replacements for Zener diodes in many applications.

The precise +/- 2% reference voltage tolerance of GM432 make it possible in many applications to avoid the use of a variable resistor, consequently saving cost and eliminating drift and reliability problems associated with it.

Features

- *Precision reference voltage
 - A Rank: 1.24V ±0.5% ,
 - B Rank: 1.24V ±1% ,
 - C Rank: 1.24V ±2.0%
- *Sink current capability: 200 mA.
- *Minimum cathode current for regulation: 150 μA.
- *Equivalent full-range temp coefficient: 30 ppm/°C.
- *Fast turn-on Response.
- *Low dynamic output impedance: 0.2Ω.
- *Programmable output voltage to 20V.
- *Low output noise.

Package Dimensions

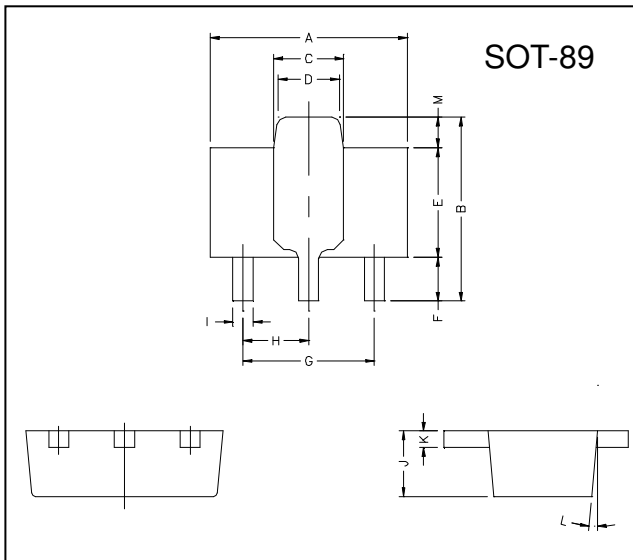

Marking :

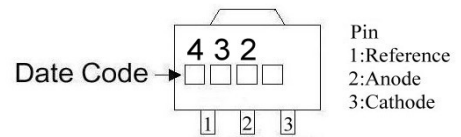

REF.	Millimeter		REF.	Millimeter	
	Min.	Max.		Min.	Max.
A	4.4	4.6	G	3.00	REF.
B	4.05	4.25	H	1.50	REF.
C	1.50	1.70	I	0.40	0.52
D	1.30	1.50	J	1.40	1.60
E	2.40	2.60	K	0.35	0.41
F	0.89	1.20	L	5° TYP.	
			M	0.70 REF.	

Typical Application Circuit

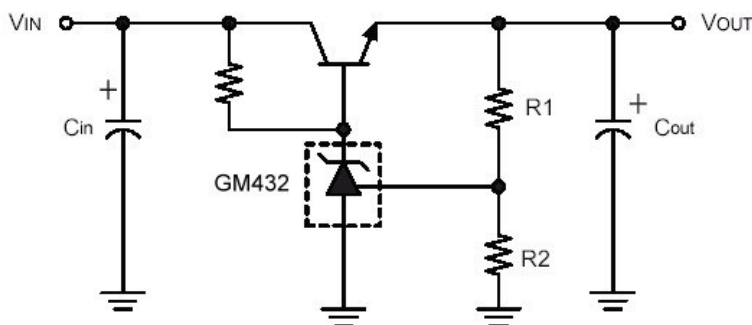

$$V_{OUT} = (1 + R1/R2)V_{REF}$$

Precision Regulator

Block Diagram

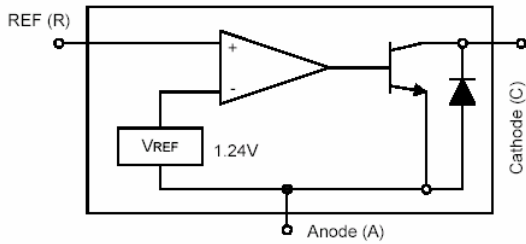

Symbol

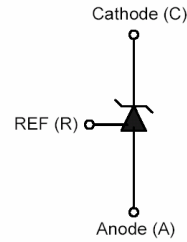

Absolute Maximum Ratings at Ta = 25°C

Parameter	Symbol	Ratings	Unit
Junction Temperature	Tj	+150	°C
Storage Temperature	Tstg	-65 ~ +150	°C
Cathode Voltage	VKA	20	V
Continuous Cathode Current	IKA	-10~+250	mA
Reference Input Current Range	IREF	-0.05~+10	mA
Total Power Dissipation	PD	225	mW

Electrical Characteristics (Ta = 25°C, unless otherwise specified.)

Parameter	Symbol	Min	Typ.	Max.	Unit	Test Conditions
Reference Voltage GM432C GM432B GM432A	VREF	1.215	1.24	1.265	V	VKA= VREF, Ik=10mA (Fig.1)
Deviation of reference Input Voltage Over temperature(note1)	$\Delta V_{REF}/\Delta T$	-	3.0	20	mV	VKA= VREF, Ik=10mA Ta=Full range (Fig.1)
Ratio of Change in Reference Input Voltage to the Change in Cathode Voltage	$\Delta V_{REF}/\Delta V_{KA}$	-	-1.4	-2.0	mV/V	Ik=10mA (Fig.2) $\Delta V_{KA}=20V \sim V_{REF}$
Reference Input Current	IREF	-	1.4	3.5	uA	Ik=10mA, R1=10K Ω , R2= ∞ (Fig.2)
Deviation of reference Input Current Over Temperature Range	αI_{REF}	-	0.4	1.2	uA	Ik=10mA, R1=10K Ω , R2= ∞ Ta=Full range(Fig.2)
Minimum Cathode Current for Regulation	IKA(min)	-	0.15	0.3	mA	VKA=VREF(Fig.1)
Off-State Cathode Current	IKA(off)	-	0.1	1.0	uA	VKA=20V, VREF=0 (Fig.3)
Dynamic Output Impedance (note2)	Zka	-	0.2	0.5	Ω	VKA=VREF, Ik=1 ~100mA F \leq 1.0KHz(Fig.1)

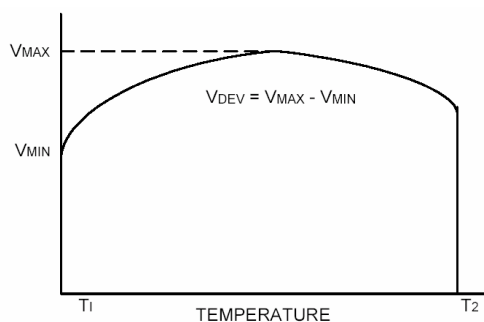

Note1. Deviation of reference input voltage, VDEV, is defined as the maximum variation of the reference over the full temperature range.

The average temperature coefficient of the reference input voltage αV_{REF} is defined as:

$$|\alpha V_{REF}| = \frac{\left(\frac{V_{DEV}}{V_{REF}(25^{\circ}C)}\right) \times 10^6}{T_2 - T_1} \dots\dots\dots (ppm/^{\circ}C)$$

Where:

$T_2 - T_1$ = full temperature change.

αV_{REF} can be positive or negative depending on whether the slope is positive or negative.

Note2. The dynamic output impedance, R_Z , is defined as:

$$|Z_{KA}| = \frac{\Delta V_{KA}}{\Delta I_{KA}}$$

When the device is programmed with two external resistors R_1 and R_2 (see figure 2.), the dynamic output impedance of the overall circuit, is defined as:

$$|Z_{KA}'| = \frac{\Delta v}{\Delta i} > |Z_{KA}| \left(1 + \frac{R_1}{R_2}\right)$$

Test Circuits

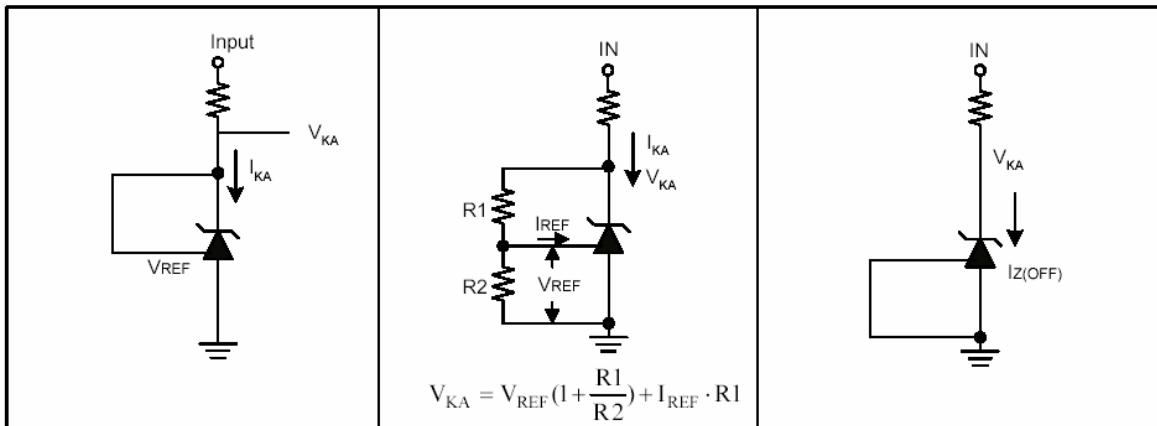
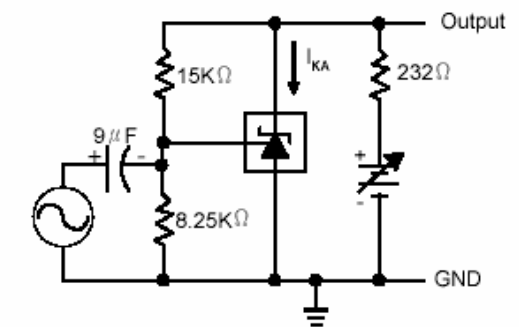
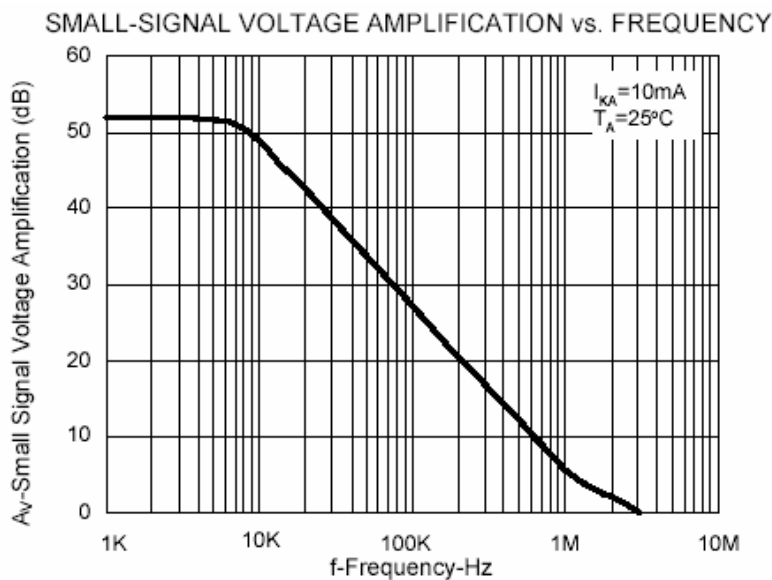

Fig1. Test Circuit for $V_{KA} = V_{REF}$

Fig2. Test circuit for $V_{KA} > V_{REF}$

Fig3. Test Circuit for off-state Current

Typical Performance Characteristics



TEST CIRCUIT FOR VOLTAGE AMPLIFICATION

REFERENCE IMPEDANCE vs. FREQUENCY

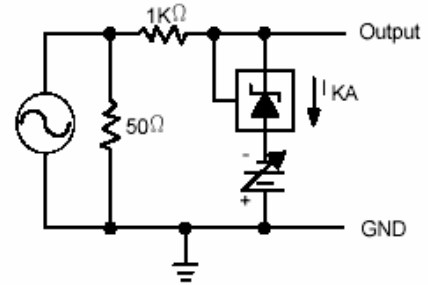
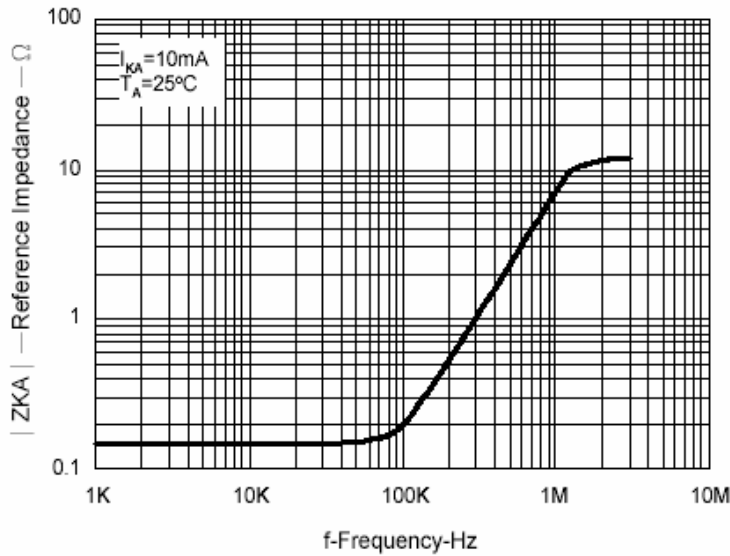

TEST CIRCUIT FOR REFERENCE IMPEDANCE

STABILITY BOUNDARY CONDITIONS†

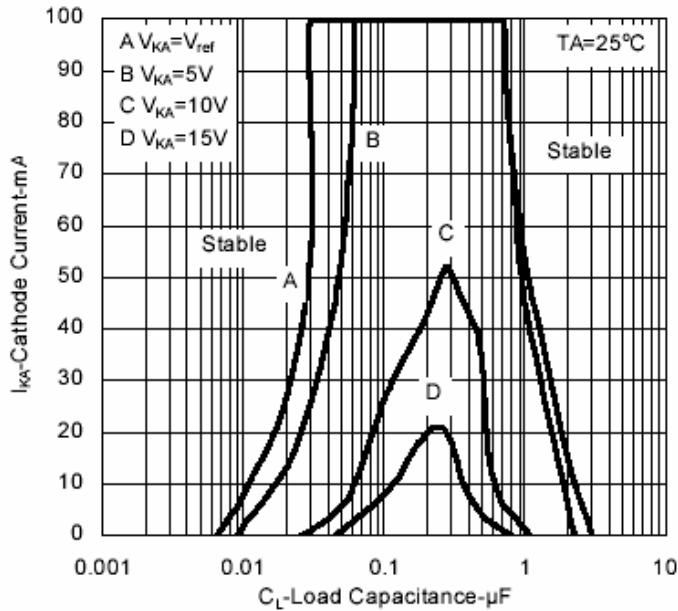

†The areas under the curves represent conditions that may cause the device to oscillate. For curves B, C, and D, R2 and V+ were adjusted to establish the initial V_{KA} and I_{KA} conditions with $C_L = 0$. V_{BATT} and C_L were then adjusted to determine the ranges of stability.

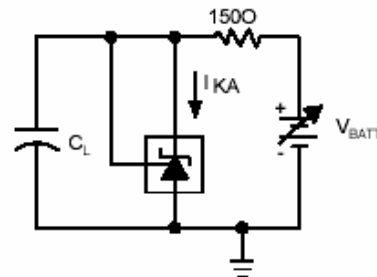

TEST CIRCUIT FOR CURVE A

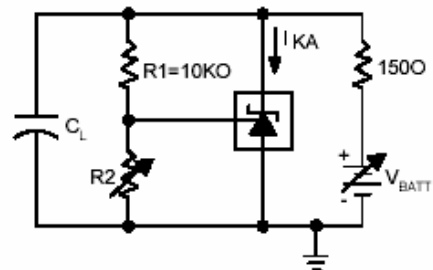

TEST CIRCUIT FOR CURVE B, C, AND D

Application Examples

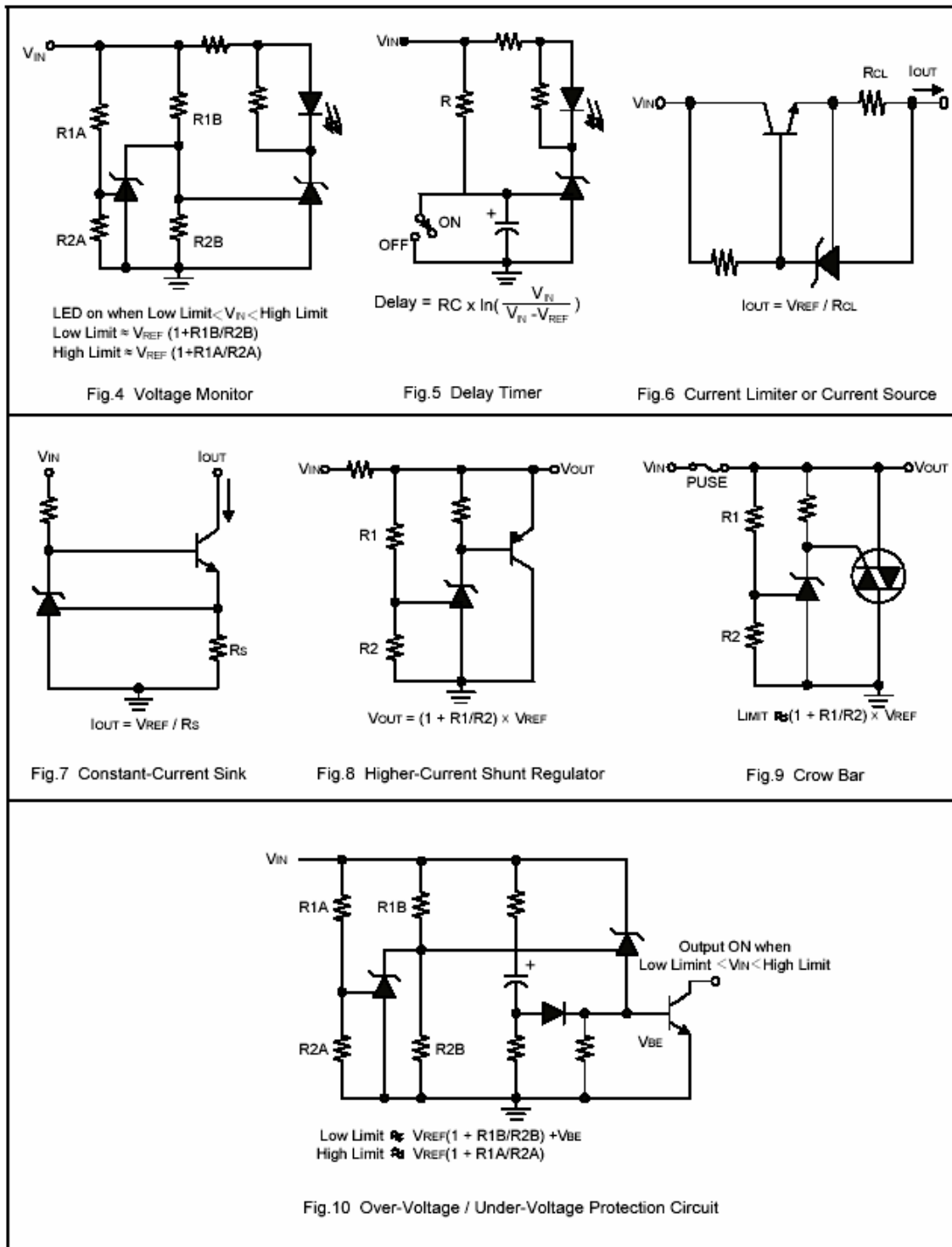

Important Notice:

- All rights are reserved. Reproduction in whole or in part is prohibited without the prior written approval of GTM.
- GTM reserves the right to make changes to its products without notice.
- GTM semiconductor products are not warranted to be suitable for use in life-support Applications, or systems.
- GTM assumes no liability for any consequence of customer product design, infringement of patents, or application assistance.

Head Office And Factory:

- **Taiwan:** No. 17-1 Tatung Rd. Fu Kou Hsin-Chu Industrial Park, Hsin-Chu, Taiwan, R. O. C.
- TEL : 886-3-597-7061 FAX : 886-3-597-9220, 597-0785
- **China:** (201203) No.255, Jang-Jiang Tsai-Lueng RD. , Pu-Dung-Hsin District, Shang-Hai City, China
- TEL : 86-21-5895-7671 ~ 4 FAX : 86-21-38950165