

RoHS Compliant Product

### Description

The S2113 series of positive, linear regulators feature low quiescent current (30uA typ.) with low dropout voltage, making them ideal for battery applications. These rugged devices have both Thermal Shutdown, and Current Fold-back to prevent device failure under the "Worst" of operating conditions. The S2113 is stable with an output capacitance of 2.2uF or greater.

### Features

- \* High Accurate  $\pm 1.5\%$
- \* Over-Temperature Shutdown
- \* Factory Pre-set Output Voltage
- \* Very Low Dropout Voltage
- \* Low Temperature Coefficient
- \* Short Circuit Current Fold-back
- \* Guaranteed 300mA output
- \* Current Limiting

### Applications

- \* PC Peripherals
- \* Wireless Devices
- \* Portable Electronics
- \* Battery Powered Widgets
- \* Electronic Scales
- \* Instrumentation
- \* Cordless Phones

TO-92

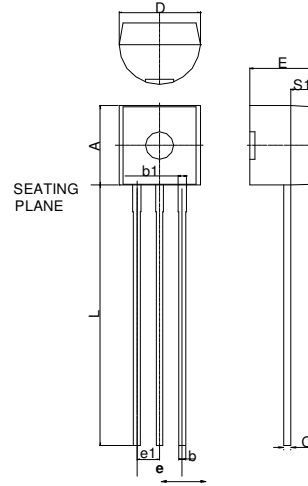

REF.	Millimeter		REF.	Millimeter	
	Min.	Max.		Min.	Max.
A	4.45	4.7	D	4.44	4.7
S1	1.02	-	E	3.30	3.81
b	0.36	0.51	L	12.70	-
b1	0.36	0.76	e1	1.150	1.390
C	0.36	0.51	e	2.42	2.66

### Marking :

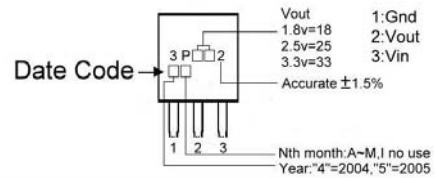

### Block Diagram

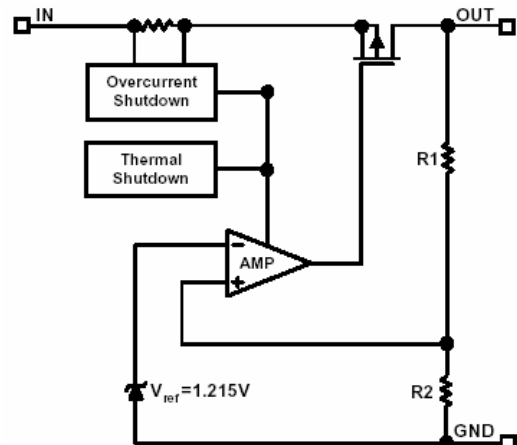

### Typical Application Circuit

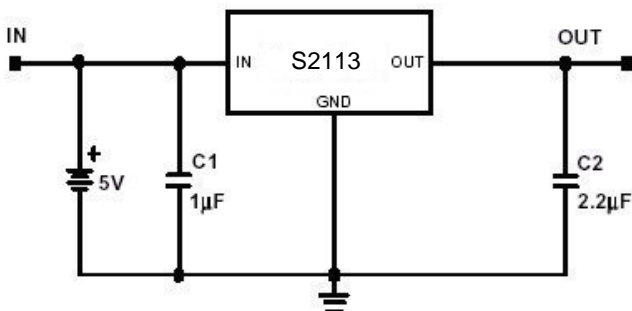

## Absolute Maximum Ratings

Parameter	Symbol	Ratings	Unit
Input Voltage	$V_{IN}$	8	V
Output Current	$I_{OUT}$	$P_D/(V_{IN}-V_O)$	mA
Output Voltage	$V_{OUT}$	1.3~5	V
Operating Ambient Temperature	$T_{opr}$	-40~+85	°C
Junction Temperature	$T_j$	-40~+125	°C
Max. Junction Temperature	$T_j \text{ Max.}$	150	°C
Thermal Resistance	$\theta_{jc}$	80	W/°C
	$\theta_{ja}$	180	W/°C
Power Dissipation ( $\Delta T=100^\circ\text{C}$ )	$P_D$	625	mW
EDS Classification		B	

## Electrical Characteristics $T_a=25^\circ\text{C}$

Parameter	Symbol	Min.	Typ.	Max.	Unit	Condition	
Output Voltage	$V_{OUT(E)}^1$	-1.5%	$V_{OUT(E)}^2$	1.5%	V	$V_{IN}=V_{OUT(T)}+1V, I_o=1mA$	
Output Current	$I_o$	300	-	-	mA	$V_{IN}=V_{OUT(T)}+2V, V_{OUT} \geq V_{OUT(E)} \cdot 0.96$	
Current Limit	$I_{LIM}$	300	450	-	mA	$V_o > 1.2V$	
Load Regulation	$REG_{LOAD}$	-1	0.2	1	%	$V_{IN}=V_{OUT(T)}+2V, I_o=1mA \text{ to } 300mA$	
Dropout Voltage	$V_{DROPOUT}$	-	-	1300	mV	$1.3V \leq V_{OUT(T)} \leq 2.0V$	$I_o=300mA$ $V_o=V_{OUT(E)}-2\%$
		-	-	400		$2.0V < V_{OUT(T)} \leq 2.8V$	
		-	-	300		$2.8V < V_{OUT(T)}$	
Quiescent Current	$I_q$	-	30	50	µA	$V_{IN}=V_{OUT(T)}+1V$	
Line Regulation	$REG_{LINE}$	-0.2	-	0.2	%	$1.3V \leq V_{OUT(T)} \leq 1.4V$	$I_o=1mA$ $V_{IN}=V_{OUT(T)}+1$ to $V_{OUT(T)}+2$
		-0.15	-	0.15		$1.4V < V_{OUT(T)} \leq 2.0V$	
		-0.1	0.02	0.1		$2.0V < V_{OUT(T)} < 4.0V$	
		-0.4	0.2	0.4		$4.0V \leq V_{OUT(T)}$	
Input Voltage	$V_{IN}$	Note <sup>3</sup>	-	7	V		
Over Temperature Shutdown	$O_{TS}$	-	150	-	°C		
Over Temperature Hystersis	$O_{TH}$	-	30	-	°C		
Output Voltage Temperature Coefficient	$T_C$	-	30	-	ppm/°C		
Short Circuit Current <sup>4</sup>	$I_{SC}$	-	150	300	mA	$V_{IN}=V_{OUT(T)}+1V, V_{OUT}=0V$	
PSRR	PSRR	-	50	-	dB	$f=1kHz$	$I_o=100mA$ $C_o=2.2\mu F$
		-	20	-		$f=10kHz$	
		-	15	-		$f=100kHz$	
Output Voltage Noise	eN	-	30	-	µVrms	$C_o=2.2\mu F$ $f=10Hz \sim 100kHz$ $I_o=10mA$	

Note 1:  $V_{OUT(E)}$  =Effective Output Voltage (i.e. the output voltage when " $V_{OUT(T)} + 1.0V$ " is provided at the  $V_{IN}$  pin while maintaining a certain  $I_{OUT}$  value).

2:  $V_{OUT(T)}$  =Specified Output Voltage

3:  $V_{IN(MIN)} = V_{OUT} + V_{DROPOUT}$

4: To prevent the Short Circuit Current protection feature from being prematurely activated, the input voltage must be applied before a current source load is applied.

## Ordering Information(contd.)

Part Number	Marking	Output Voltage	Part Number	Marking	Output Voltage
S2113-15	3P152 XX	1.5V	S2113-18	3P182 XX	1.8V
S2113-25	3P252 XX	2.5V	S2113-27	3P272 XX	2.7V
S2113-2H	3P2H2 XX	2.85V	S2113-28	3P282 XX	2.8V
S2113-29	3P292 XX	2.9V	S2113-30	3P302 XX	3.0V
S2113-31	3P312 XX	3.1V	S2113-33	3P332 XX	3.3V
S2113-34	3P342 XX	3.4V	S2113-35	3P352 XX	3.5V
S2113-36	3P362 XX	3.6V	S2113-37	3P372 XX	3.7V
S2113-38	3P382 XX	3.8V			

## Characteristics Curve

