

RoHS Compliant Product

Description

The SU1084 is a low dropout at positive adjustable or fixed-mode regulator with min. of 5A output current capability. The product is specifically designed to provide well-regulated supply for low voltage IC applications such as high-speed bus termination and low current 3.3V logic supply. SU1084 is also well suited for other applications such as VGA cards. SU1084 is guaranteed to have lower than 1.5V dropout at full load current making it ideal to provide well regulated outputs of 1.25V to 3.3V with 4.7 to 12V input supply.

Features

- * 1.5V Max. Dropout At Full Load Current
- * Adjustable Output Voltage or Fixed 1.5V, 1.8V, 2.5V, 3.3V, 5.0V
- * Output Current Limiting
- * Good Noise Rejection
- * Fast Transient Response
- * Built-in Thermal Shutdown

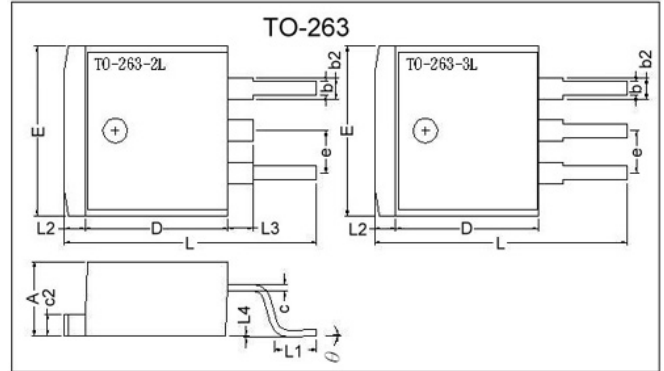

| REF. | Millimeter | | REF. | Millimeter | |
|------|------------|------|------|------------|------|
| | Min. | Max. | | Min. | Max. |
| A | 4.40 | 4.80 | c2 | 1.25 | 1.45 |
| b | 0.76 | 1.00 | b2 | 1.17 | 1.47 |
| L4 | 0.00 | 0.30 | D | 8.6 | 9.0 |
| c | 0.36 | 0.5 | e | 2.54 | REF. |
| L3 | 1.50 | REF. | L | 14.6 | 15.8 |
| L1 | 2.29 | 2.79 | θ | 0° | 8° |
| E | 9.80 | 10.4 | L2 | 1.27 | REF. |

Block Diagram

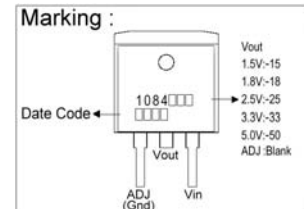
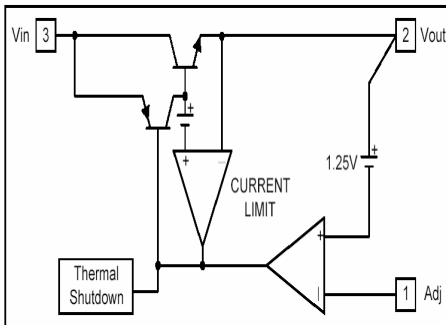

Typical Circuit

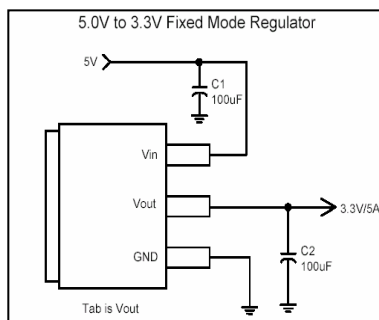
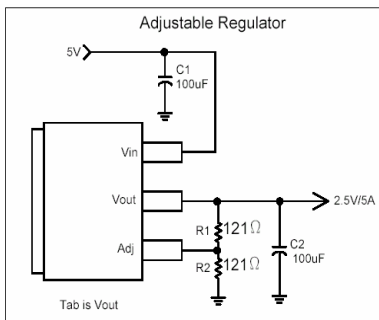

Pin Descriptions

| Name | I/O | PIN# | FUNCTION |
|-----------|-----|------|--|
| Adj (GND) | | 1 | Adjustable (Ground only for fixed mode) |
| Vout | O | 2 | The output of the regulator. A minimum of 10uF capacitor must be connected from this pin to ground to insure stability. |
| Vin | I | 3 | The input pin of regulator .Typically a large storage capacitor is connected from this pin to ground to insure that the input voltage does not sag below the minimum dropout voltage during the load transient response .This pin must always be 1.5V higher than Vout in order for the device to regulate properly. |

Absolute Maximum Ratings

| Parameter | Symbol | Ratings | Unit |
|--------------------------------------|-----------------|--------------------|------|
| DC Supply Voltage | V _{IN} | -0.3 to 12 | V |
| Power Dissipation | P _D | Internally Limited | |
| Storage Temperature Range | T _{ST} | -65~+150 | °C |
| Operating Junction Temperature Range | T _{OP} | 0~+150 | °C |

Electrical Characteristics

| Symbol | Parameter | Conditions(Notes) | MIN | TYP | MAX | UNIT |
|------------------|---|---|-------|-------|-------|------|
| V _{REF} | SU1084ADJ | I _o =10mA, T _j =25°C, (V _{in} -V _{out})=1.5V | 1.225 | 1.250 | 1.275 | V |
| Output Voltage | SU1084-1.5 | I _o =10mA, T _j =25°C, 3.0V≤V _{in} ≤12V | 1.470 | 1.500 | 1.530 | V |
| | SU1084-1.8 | I _o =10mA, T _j =25°C, 3.3V≤V _{in} ≤12V | 1.764 | 1.800 | 1.836 | V |
| | SU1084-2.5 | I _o =10mA, T _j =25°C, 4.0V≤V _{in} ≤12V | 2.450 | 2.500 | 2.550 | V |
| | SU1084-3.3 | I _o =10mA, T _j =25°C, 4.8V≤V _{in} ≤12V | 3.235 | 3.300 | 3.365 | V |
| | SU1084-5.0 | I _o =10mA, T _j =25°C, 6.5V≤V _{in} ≤12V | 4.900 | 5.000 | 5.100 | V |
| Line Regulation | SU1084XXX | I _o =10mA, V _{out} +1.5V<V _{in} <12V, T _j =25°C | - | - | 0.2 | % |
| Load Regulation | SU1084ADJ | V _{in} =3.3V, 0mA<I _o <5A, T _J =25°C (Note 1,2) | - | - | 1 | % |
| | SU1084-1.5 | V _{in} =3.0V, 0mA<I _o <5A, T _J =25°C (Note 1,2) | - | 12 | 15 | mV |
| | SU1084-1.8 | V _{in} =3.3V, 0mA<I _o <5A, T _J =25°C (Note 1,2) | - | 15 | 18 | mV |
| | SU1084-2.5 | V _{in} =4.0V, 0mA<I _o <5A, T _J =25°C (Note 1,2) | - | 20 | 25 | mV |
| | SU1084-3.3 | V _{in} =5.0V, 0mA<I _o <5A, T _J =25°C (Note 1,2) | - | 26 | 33 | mV |
| | SU1084-5.0 | V _{in} =8.0V, 0mA<I _o <5A, T _J =25°C (Note 1,2) | - | 40 | 50 | mV |
| ΔV _o | Dropout Voltage | I _o =5.0A(ΔV _{out} =1% V _{out}) | - | 1.4 | 1.5 | V |
| I _{LIM} | Current Limit | V _{in} -V _{out} =5V | 5.1 | - | - | A |
| I _{MIN} | Minimum Load Current | V _{in} =5V (adjustable model) | - | 5 | 10 | mA |
| I _{ADJ} | Adjust Pin Current | V _{in} =12V, I _o =10mA | - | 55 | 100 | uA |
| I _Q | Quiescent Current | V _{in} =12V, I _o =0mA (fixed model) | - | - | 12 | mA |
| | Temperature Stability | I _o =10mA | - | 0.5 | - | % |
| θ _{JA} | Thermal Resistance Junction-to-Ambient(No heat sink ;No air flow) | | - | 91 | - | °C/w |
| θ _{JC} | Thermal Resistance Junction-to-Case | | - | 10 | - | °C/w |

Note 1: See thermal regulation specifications for changes in output voltage due to heating effects. Line and load regulation are measured at a constant junction Temperature by low duty cycle pulse testing .Load regulation is measured at the output lead =1/18" from the package.

Note 2: Line and load regulation are guaranteed up to the maximum power dissipation of 15W. Power dissipation is determined by the difference between input and output and the output current .Guaranteed maximum power dissipation will not be available over the full input/output range.

Functional Description

Introduction

The SU1084 adjustable Low Dropout (LDO) regulator is a 3 terminal device that can easily be programmed with the addition of two external resistors to any voltages within the range of 1.25V to 2.5V. The SU1084 only needs 1.5V differential between V_{in} and V_{out} to maintain output regulation, the output voltage tolerances are also extremely tight and they include the transient response as part of the specification. For example, Intel VRE specification calls for a total of +/-100mV including initial tolerance, load regulation and 0 to 5.0A load step. The SU1084 is specifically designed to meet the fast current transient needs as well as providing an accurate initial voltage, reducing the overall system cost with the need for fewer output capacitors.

Output Voltage Setting

The SU1084 can be programmed to any voltages in the range of 1.25V to 5V with the addition of R1 and R2 external resistors According to the following formula:

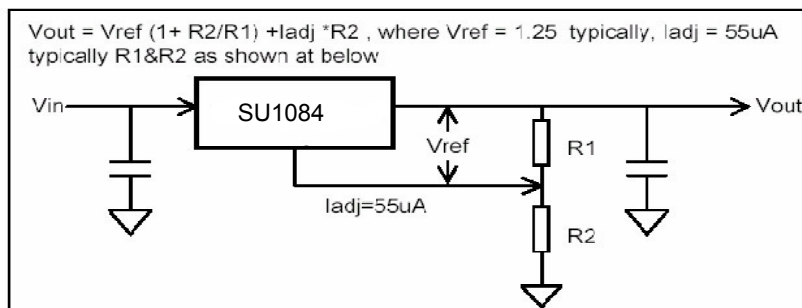

The SU1084 keeps a constant 1.25V between the output pin and the adjust pin. By placing a resistor R1 across these two pins a constant current flows through R1, adding to the **Iadj** current requirement of the SU1084 is 10mA, R1 is typically selected to be 121Ω resistor so that it automatically satisfies the minimum current requirement. Notice that since **Iadj** is typically in the range of 55uA it only adds a small error to the output voltage and should only be considered when a very precise output voltage setting is required. For example, in a typical 3.3V application where R1=121Ω and R2=200Ω the error due to **Iadj** is only 0.3% of the nominal set point.

Load Regulation

Since the SU1084 is only a 3 terminal device, it is not possible to provide true remote sensing of the output voltage at the load.

The best load Regulation is achieved when the bottom side of R2 is connected to the load and the top-side of R1 resistor is connected directly to the case or the V_{out} pin of the regulator and not to the load. It is important to note that for high current applications, this can re-present a significant percentage of the overall load regulation and one must keep the path from the regulator to the load as short as possible to minimize this effect.

Stability

The SU1084 requires the use of an output capacitor as part of the frequency compensation in order to make the regulator stable. For most applications a minimum of 10uF aluminum electrolytic capacitor insures both stability and good transient response.

Thermal Design

The SU1084 incorporates an internal shutdown that protects the device when the junction temperature exceeds the maximum allowable junction temperatures. Although this device can operate with junction temperatures in the range of 150°C, it is recommended that the selected heat sink be chosen such that during maximum continuous load operation the junction temperature is kept below the temperature.

Layout Consideration

The output capacitors must be located as close to the V_{out} terminal of the device as possible. It is recommended to use a section of a layer of the PC board as a plane to connect the V_{out} pin to the output capacitors to prevent any high frequency oscillation that may result due to excessive trace inductance.

Performance Characteristics

