

**FEATURES**

- 3% Dynamic EVM @ P<sub>OUT</sub> = +18 dBm with IEEE 802.11a 64 QAM OFDM at 54 Mbps
- 3% Dynamic EVM @ P<sub>OUT</sub> = +20 dBm with IEEE 802.11g 64 QAM OFDM at 54 Mbps
- -30 dBc 1st Sidelobe / -50 dBc 2nd Sidelobe at +23 dBm w/ IEEE 802.11b, 1 Mbps CCK/DSSS
- 31 dB of Linear Power Gain in 2 GHz and 5 GHz Transmit Paths
- 2.6 dB Noise Figure in 2 GHz Receive Path and 3.0 dB in 5 GHz Receive Path
- Single +3.3 V Nominal Supply
- SP3T RF Switch w/Bluetooth and 2 GHz Tx/Rx
- SP2T RF Switch for 5 GHz Tx/Rx Function
- Independent Switch Control for BT, 2 GHz, and 5 GHz Tx/Rx Paths
- 12 dB Gain in 2 GHz Receive Path and 14 dB in 5 GHz Receive Path
- LNA Bypass Mode in 2 GHz and 5 GHz Receive Paths
- 50 Ω - Matched RF Ports
- Leadfree Package
- Materials set consistent with RoHS Directive
- 4.0 x 4.0 x 0.55 mm QFN Package

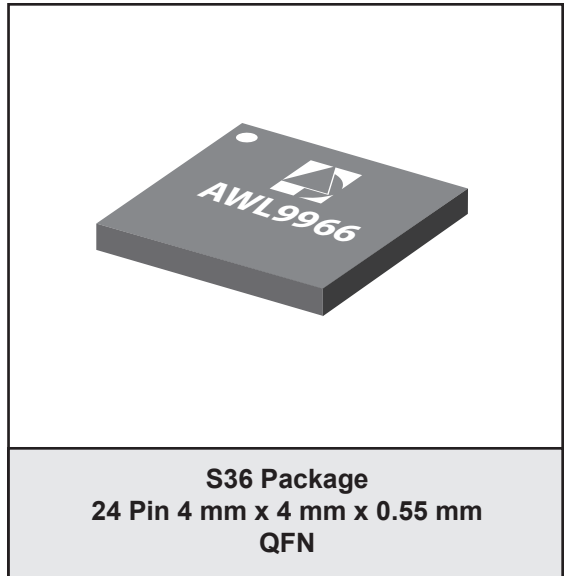

A single temperature-compensated power detector is used in the FEIC to serve both WLAN bands. The detector provides a single-ended output voltage with excellent accuracy over a wide range of operating temperatures. All circuits are biased by a single +3.3V supply and consume ultra-low current in the OFF mode.

**APPLICATIONS**

- 802.11a/b/g/n WLAN for Fixed, Mobile, and Handheld applications

**PRODUCT DESCRIPTION**

The ANADIGICS AWL9966 is a high performance FEIC that incorporates dual band power amplifiers, low-noise amplifiers, RF switches, and filters. The FEIC is designed for WLAN transmit and receive applications in the 2.412-2.484 GHz and 5.15-5.85 GHz bands. Matched to 50 Ohms at all RF inputs and outputs, the part requires no additional RF matching components off-chip. The antenna ports are switched between WLAN transmit, WLAN receive, Bluetooth, and simultaneous WLAN and Bluetooth paths with low loss RF switches. The PAs exhibit unparalleled linearity and efficiency for IEEE 802.11g, 802.11b, 802.11a and 802.11n WLAN systems under the toughest signal configurations within these standards.

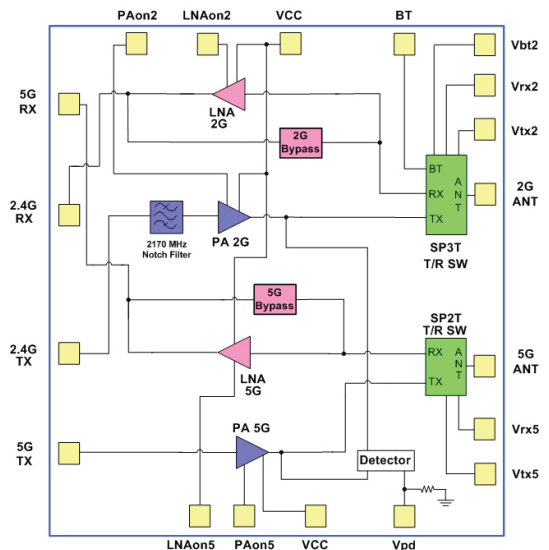

**Figure 1: Block Diagram and Pinout**

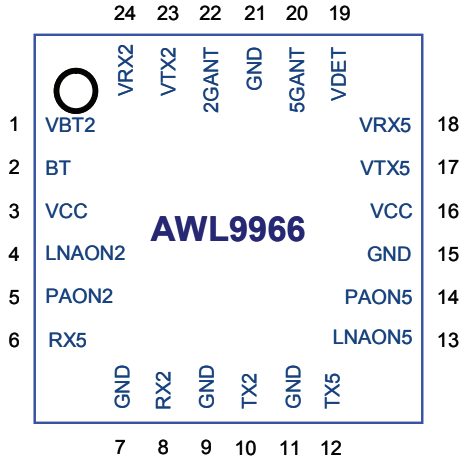

Figure 2: Pinout Diagram

Table 1: Pin Description

PIN	NAME	DESCRIPTION	PIN	NAME	DESCRIPTION
1	VBT2	Bluetooth enable. On/Off control for the Bluetooth RF path.	13	LNAON5	5 GHz LNA Enable. On/Off control for the 5 GHz receive path low noise amplifier.
2	BT	Bluetooth RF port.	14	PAON5	5 GHz PA Enable. On/Off control for the 5 GHz transmit path power amplifier.
3	VCC	Power Supply. Bias for transistors.	15	GND	Ground.
4	LNAON2	2 GHz LNA Enable. On/Off control for the 2 GHz receive path low noise amplifier.	16	VCC	Power Supply. Bias for transistors.
5	PAON2	2 GHz PA Enable. On/Off control for the 2 GHz transmit path power amplifier.	17	VTX5	Switch control for 5 GHz transmit path.
6	RX5	5 GHz RF receive output port.	18	VRX5	Switch control for 5 GHz receive path.
7	GND	Ground.	19	VDET	Power Detector Output. DC coupled power detector output
8	RX2	2 GHz RF receive output port.	20	5GANT	5 GHz Antenna Port.
9	GND	Ground.	21	GND	Ground.
10	TX2	2 GHz RF transmit input port.	22	2GANT	2 GHz Antenna Port.
11	GND	Ground.	23	VTX2	Switch control for 2 GHz transmit path.
12	TX5	5 GHz RF transmit input port.	24	VRX2	Switch control for 2 GHz receive path.

## ELECTRICAL CHARACTERISTICS

**Table 2: Absolute Minimum and Maximum Ratings**  
**Operating Conditions: T<sub>c</sub>=+25 °C, V<sub>cc</sub>=+3.3 V, V<sub>controls</sub>=+3.3 V**

PARAMETER	MIN	MAX	UNIT	COMMENTS
DC Power Supply Voltages (VCC)	-	+6.0	V	
RF Input Level, 2.4 GHz PA, 5 GHz PA		+5	dBm	Modulated
Case Temperature	-40	+85	C	
Storage Temperature	-55	+85	C	
Storage Humidity	-	60	%	
Shipping Temperature	-55	+150	C	
Shipping Humidity	-	60	%	
ESD Tolerance	400	-	V	Human body model (HBM), all pins
MSL Rating	-	MSL-2		

**Notes:**

1. Stresses in excess of the absolute ratings may cause permanent damage. Functional operation is not implied under these conditions. Exposure to absolute ratings for extended periods of time may adversely affect reliability.

**Table 3: Operating Ranges**

PARAMETER	MIN	TYP	MAX	UNIT	COMMENTS
Operating Frequency Ranges	2412 5150		2484 5850	MHz	802.11b/g 802.11a
DC Power Supply Voltage (V <sub>cc</sub> )	+3.0	+3.3	+4.2	V	With RF applied
Control Pin Voltage (PA <sub>ON2</sub> , LNA <sub>ON2</sub> , PA <sub>ON5</sub> , LNA <sub>ON5</sub> , V <sub>BT2</sub> , V <sub>Rx2</sub> , V <sub>Tx2</sub> , V <sub>Rx5</sub> , V <sub>Tx5</sub> )	+2.8 0	+3.3 0	+4.2 +0.5	V	Logic High/On Logic Low/Off
Case Temperature	-40		+85	°C	

**NOTES:**

The device may be operated safely over these conditions; however, parametric performance is guaranteed only over the conditions defined in the electrical specifications.

**Table 4: Electrical Specifications - 802.11b/g Transmit Path**  
 (T<sub>c</sub> = +25 °C, V<sub>CC</sub> = +3.3 V, PA<sub>ON2</sub> = +3.3 V, V<sub>TX2</sub> = +3.3 V, V<sub>RX2</sub> = V<sub>BT2</sub> = 0 V)  
 Static Mode 64 QAM OFDM 54 Mbps

PARAMETER	MIN	TYP	MAX	UNIT	COMMENTS
Operating Frequency	2412		2484	MHz	
Power Gain		31		dB	
Gain Flatness		+/-1.0 +/-0.5		dB	Across full band Across any 40 MHz band
Error Vector Magnitude (EVM) <sup>(1)</sup>		-30 190		dB mA	P <sub>OUT</sub> = 20 dBm, Dyn Mode 54 Mbps data rate, Avg during packet
		-33 175		dB mA	P <sub>OUT</sub> = 19 dBm, Dyn Mode 54 Mbps data rate, Avg during packet
		-36 140		dB mA	P <sub>OUT</sub> = 16 dBm, Dyn Mode 54 Mbps data rate, Avg during packet
		-40 95		dB mA	P <sub>OUT</sub> = 5 dBm, Dyn Mode 54 Mbps data rate, Avg during packet
ACPR Sidelobe 1	-30			dBc	P <sub>OUT</sub> = 23 dBm, CCK 1 - 11 Mbps Root cosine filtering, α = 0.45
ACPR Sidelobe 2	-50			dBc	P <sub>OUT</sub> = 23 dBm, CCK 1 - 11 Mbps Root cosine filtering, α = 0.45
Transmit Mask	Pass			N/A	CCK, all rates, P <sub>OUT</sub> = 23 dBm; OFDM, all rates, P <sub>OUT</sub> = 20 dBm
PA Noise Figure		8		dB	
PA Out of Band Noise Power		-150		dBm/Hz	WCDMA RX Band (2.11 to 2.17 GHz)
P <sub>SAT</sub>		26		dBm	
Group Delay		2.5		nS	
Group Delay Variation		0.5		nS	For any 20 MHz channel
Return Loss, Input		12		dB	50 Ω
Return Loss, Output		10		dB	50 Ω
TX Output Spurious Levels 2 fo 3 fo 4 fo		-20 -30 -45		dBm/MHz	For power levels up to 23 dBm, CCK @ 1 Mbps

Note:

(1) EVM includes system noise floor of 1% (-40 dB).

**Table 4: Electrical Specifications - 802.11b/g Transmit Path (Continued)**  
 (T<sub>c</sub> = +25 °C, V<sub>CC</sub> = +3.3 V, PA<sub>ON2</sub> = +3.3 V, V<sub>TX2</sub> = +3.3 V, V<sub>RX2</sub> = V<sub>BT2</sub> = 0 V)  
 Static Mode 64 QAM OFDM 54 Mbps

PARAMETER	MIN	TYP	MAX	UNIT	COMMENTS
TX Output Spurious Levels Non-Harmonics		-60		dBm/MHz	For power levels up to 23 dBm, CCK @ 1 Mbps
Stability and Load Mismatch Susceptibility		-65		dBc	Unconditionally stable and no damage, 5:1 VSWR, up to P <sub>OUT</sub> = 20 dBm, OFDM 54 Mbps
Settling Time		0.5	1.0	uS	Within 0.5 dB of final value
I <sub>CC</sub> Quiescent Current		95		mA	
Shutdown Current			10	uA	PA <sub>ON2</sub> set low

**Table 5: Electrical Specification - 2 GHz Receive Path - LNA Mode**  
 (T<sub>c</sub> = +25 °C, V<sub>CC</sub> = +3.3 V, LNA<sub>ON2</sub> = +3.3 V, V<sub>RX2</sub> = +3.3 V, V<sub>TX2</sub> = V<sub>BT2</sub> = 0 V)

PARAMETER	MIN	TYP	MAX	UNIT	COMMENTS
Operating Frequency	2412		2484	MHz	
Power Gain		12		dB	
Gain Flatness		+/-0.5 +/-0.25		dB	Across full band Across any 40 MHz band
Noise Figure		2.6		dB	
Reverse Isolation		18		dB	
Group Delay		2.5		nS	
Group Delay Variation		0.5		nS	For any 20 MHz channel
Input Return Loss		5		dB	50 Ω
Output Return Loss		8		dB	50 Ω
IIP3		-5		dBm	
IP1dB		-13		dBm	
Settling Time		0.5	1.0	uS	Within 0.5 dB of final value
I <sub>CC</sub> Quiescent Current		12		mA	

**Table 6: Electrical Specification - 2 GHz Receive Path - Bypass Mode**  
 (T<sub>c</sub> = +25 °C, V<sub>CC</sub> = +3.3 V, LNA<sub>ON2</sub> = 0 V, V<sub>RX2</sub> = +3.3 V, V<sub>TX2</sub> = V<sub>BT2</sub> = 0 V)

PARAMETER	MIN	TYP	MAX	UNIT	COMMENTS
Operating Frequency	2412		2484	MHz	
Insertion Loss		3.5		dB	
Gain Flatness		+/-0.5 +/-0.25		dB	Across full band Across any 40 MHz band
Input Return Loss		10		dB	50 Ω
Output Return Loss		10		dB	50 Ω
IIP3		28		dBm	
IP1dB		22		dBm	
Settling Time		0.5	1.0	μS	Within 0.5 dB of final value
I <sub>cc</sub> Leakage Current		<1		μA	LNA <sub>ON2</sub> set low

**Table 7: Electrical Specification - Bluetooth TX/RX**  
 (T<sub>c</sub> = +25 °C, V<sub>CC</sub> = 0 V, LNA<sub>ON2</sub> = 0 V, V<sub>RX2</sub> = 0 V, V<sub>BT2</sub> = +3.3 V, V<sub>TX2</sub> = 0 V)

PARAMETER	MIN	TYP	MAX	UNIT	COMMENTS
Operating Frequency	2402		2480	MHz	
Insertion Loss		0.8		dB	
Gain Flatness		+/-0.25		dB	Across any 40 MHz band
Input Return Loss	10			dB	
Output Return Loss	10			dB	
BT - RX Isolation	20			dB	
BT - TX Isolation	20			dB	
Settling Time		0.5	1.0	μS	
I <sub>cc</sub> Leakage Current		<1		μA	

**Table 8: Electrical Specification - 802.11a Transmit Path**  
 (T<sub>c</sub> = +25 °C, V<sub>CC</sub> = +3.3 V, PA<sub>ON5</sub> = +3.3 V, V<sub>TX5</sub> = +3.3 V, V<sub>RX5</sub> = 0 V,  
 Static Mode 64 QAM OFDM 54 Mbps)

PARAMETER	MIN	TYP	MAX	UNIT	COMMENTS
Operating Frequency	5150		5850	MHz	
Power Gain		31		dB	
Gain Flatness		+/-2.0 +/-0.5		dB	Across full band Across any 40 MHz band
Error Vector Magnitude (EVM) <sup>(1)</sup>		-30 160		dB mA	P <sub>OUT</sub> = 18 dBm, Dyn Mode 54 Mbps data rate, Avg during packet
		-33 130		dB mA	P <sub>OUT</sub> = 15 dBm, Dyn Mode 54 Mbps data rate, Avg during packet
		-40 90		dB mA	P <sub>OUT</sub> = 5 dBm, Dyn Mode 54 Mbps data rate, Avg during packet-
Transmit Mask	Pass			N/A	OFDM, All rates, P <sub>OUT</sub> = 18 dBm
PA Noise Figure		8		dB	
Group Delay		1.5		nS	
Group Delay Variation		0.5		nS	For any 20 MHz channel
Input Return Loss		10		dB	
Output Return Loss		12		dB	
TX Output Spurious Levels 2 fo 3 fo 4 fo		-26 -42 -60		dBm/ MHz	For power levels up to 18 dBm, OFDM @ 54 Mbps
TX Output Spurious Levels Non-Harmonics		-60		dBm/ MHz	For power levels up to 18 dBm, OFDM @ 54 Mbps
Stability and Load Mismatch Susceptibility		-65		dBc	Unconditionally stable and no damage, 5:1 VSWR, up to P <sub>OUT</sub> = 18 dBm, OFDM @ 54 Mbps
Settling Time		0.5	1.0	uS	Within 0.5 dB of final value
I <sub>CC</sub> Quiescent Current		90		mA	
Shutdown Current			10	uA	PA <sub>ON5</sub> set low

Note:

(1) EVM includes system noise floor of 1% (-40 dB).

**Table 9: Electrical Specification - 5 GHz Receive Path - LNA Mode**  
 (T<sub>c</sub> = +25 °C, V<sub>cc</sub> = +3.3 V, LNA<sub>ON5</sub> = +3.3 V, V<sub>Rx5</sub> = +3.3 V, V<sub>Tx5</sub> = 0 V)

PARAMETER	MIN	TYP	MAX	UNIT	COMMENTS
Operating Frequency	5150		5850	MHz	
Power Gain		14		dB	
Gain Flatness		+/-1.0 +/-0.25		dB	Across full band Across any 40 MHz band
Noise Figure		3.0		dB	
Reverse Isolation		30		dB	
Reverse Isolation		30		dB	
Group Delay		2.0		nS	
Group Delay Variation		0.5		nS	For any 20 MHz channel
Input Return Loss		6		dB	50 Ω
Output Return Loss		10		dB	50 Ω
IIP3		-14		dBm	
IP1dB		-20		dBm	
Settling Time		0.5	1.0	uS	Within 0.5 dB of final value
I <sub>cc</sub> Quiescent Current		12		mA	



**Table 10: Electrical Specification - 5 GHz Receive Path - Bypass Mode**  
 (T<sub>C</sub> = +25 °C, V<sub>CC</sub> = +3.3 V, LNA<sub>ON5</sub> = 0 V, V<sub>Rx5</sub> = +3.3 V, V<sub>Tx5</sub> = 0 V)

PARAMETER	MIN	TYP	MAX	UNIT	COMMENTS
Operating Frequency	5150		5850	MHz	
Insertion Loss		6		dB	
Gain Flatness		+/-1.0 +/-0.25		dB	Across full band Across any 40 MHz band
Input Return Loss		12		dB	50 Ω
Output Return Loss		12		dB	50 Ω
IIP3		31		dBm	
IP1dB		25		dBm	
Settling Time		0.5	1.0	μS	Within 0.5 dB of final value
I <sub>cc</sub> Leakage Current		<1		μA	LNA <sub>ON5</sub> set low

**Table 11: Electrical Specification - Power Detector**  
 (T<sub>C</sub> = +25 °C, V<sub>CC</sub> = +3.3 V, PA<sub>ON2/5</sub> = +3.3 V, V<sub>Tx2/5</sub> = +3.3 V)

PARAMETER	MIN	TYP	MAX	UNIT	COMMENTS
Voltage Range	200		800	mV	
Total Internal Load Impedance		5		kΩ	
Dynamic Range		20		dB	
Resolution		20		mV/dB	
Video Bandwidth		5		MHz	Adjustable with External RC Load

**Table 12: Electrical Specification - Switch and Control Lines**  
 (T<sub>c</sub> = +25 °C, V<sub>cc</sub> = +3.3 V, V<sub>control</sub> pins High = +3.3 V, V<sub>control</sub> pins Low = 0 V)

PARAMETER	MIN	TYP	MAX	UNIT	COMMENTS
Control Pin Steady State Input Current (PA <sub>ON2</sub> , LNA <sub>ON2</sub> , PA <sub>ON5</sub> , LNA <sub>ON5</sub> )		200 0.5		μA	Logic High/On Logic Low/Off
Control Pin Steady State Input Current (V <sub>BT2</sub> , V <sub>RX2</sub> , V <sub>TX2</sub> , V <sub>RX5</sub> , V <sub>TX5</sub> )		150 0.5		μA	Logic High/On Logic Low/Off
Control Pin Input Impedance	3.5			kΩ	Logic High/On
TX2 - RX2 Isolation	20			dB	20 dBm
TX5 - RX5 Isolation	20			dB	18 dBm

PERFORMANCE DATA PLOTS

**Figure 3: 2 GHz Band EVM and Average Packet Current vs Modulated Output Power**  
 (T<sub>C</sub> = +25 °C, V<sub>CC</sub> = +3.3 V, PA<sub>ON2</sub> = +3.3 V, V<sub>TX2</sub> = +3.3 V, V<sub>RX2</sub> = V<sub>BT2</sub> = 0 V)  
 Static Mode 64 QAM OFDM 54 Mbps

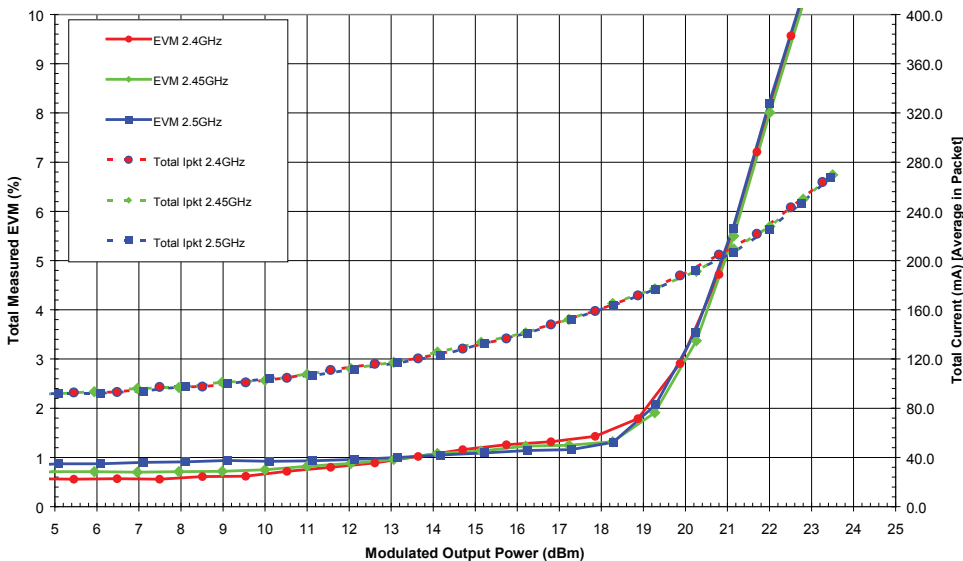

**Figure 4: 2 GHz Band Transducer Gain and Detector Voltage vs Single Tone Output Power**  
 (T<sub>C</sub> = +25 °C, V<sub>CC</sub> = +3.3 V, PA<sub>ON2</sub> = +3.3 V, V<sub>TX2</sub> = +3.3 V, V<sub>RX2</sub> = V<sub>BT2</sub> = 0 V)

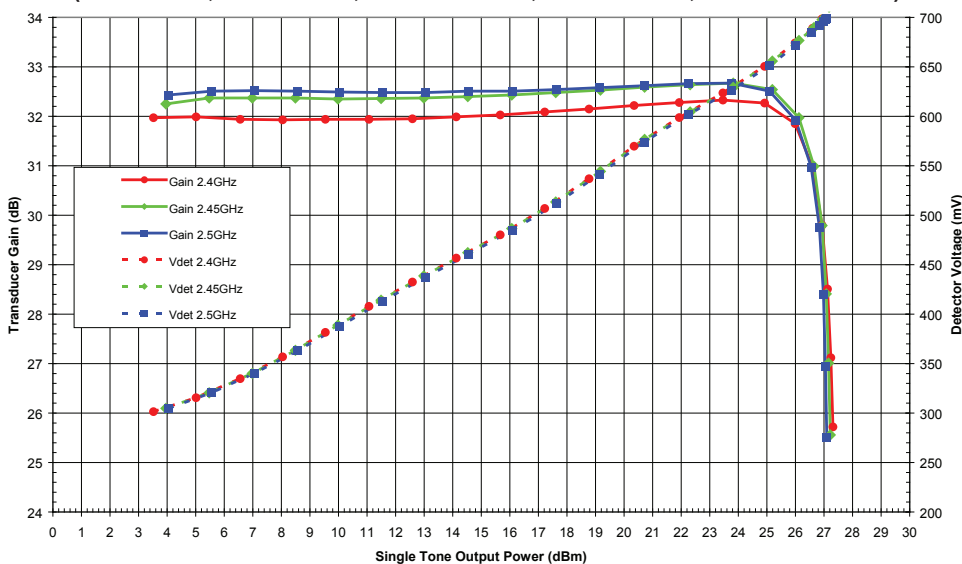

**Figure 5: 2 GHz Band Noise Figure vs Frequency**  
 (T<sub>c</sub> = +25 °C, V<sub>CC</sub> = +3.3 V, LNA<sub>ON2</sub> = +3.3 V, V<sub>RX2</sub> = +3.3 V, V<sub>TX2</sub> = V<sub>BT2</sub> = 0 V)

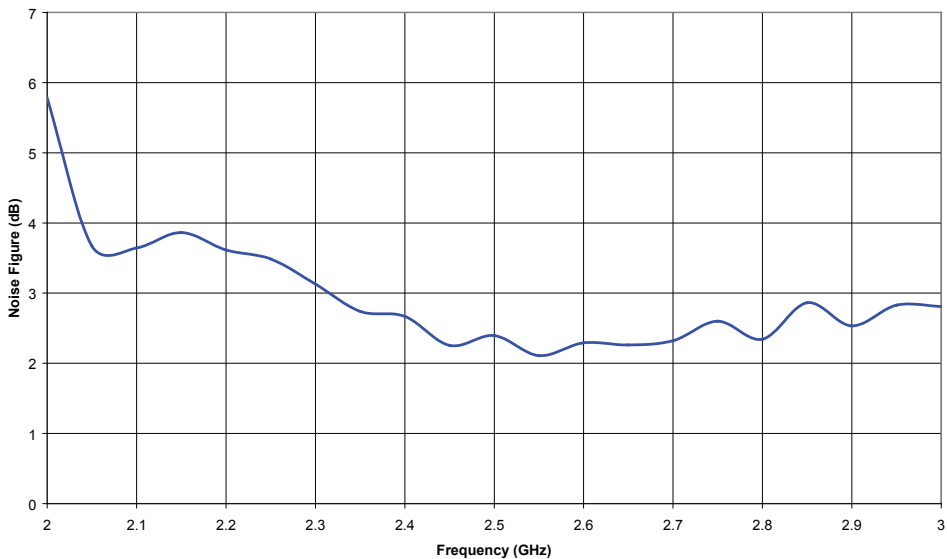

**Figure 6: 2 GHz Band RX Gain vs Frequency**  
 (T<sub>c</sub> = +25 °C, V<sub>CC</sub> = +3.3 V, LNA<sub>ON2</sub> = +3.3 V, V<sub>RX2</sub> = +3.3 V, V<sub>TX2</sub> = V<sub>BT2</sub> = 0 V)

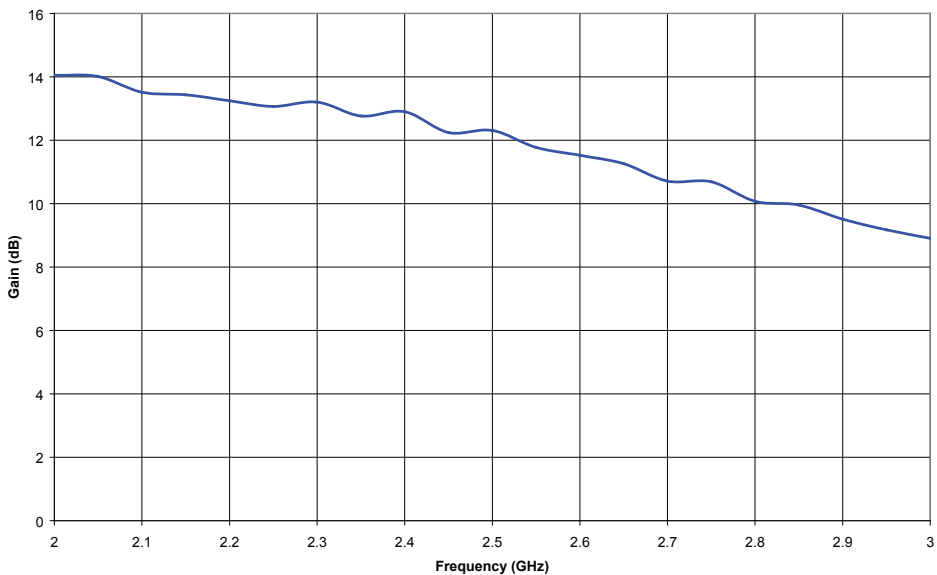

**Figure 7: Bluetooth Path S-parameters (dB) versus frequency**  
 (T<sub>C</sub> = +25 °C, V<sub>CC</sub> = 0 V, LNA<sub>ON2</sub> = 0 V, V<sub>RX2</sub> = 0 V, V<sub>BT2</sub> = +3.3 V, V<sub>TX2</sub> = 0 V)

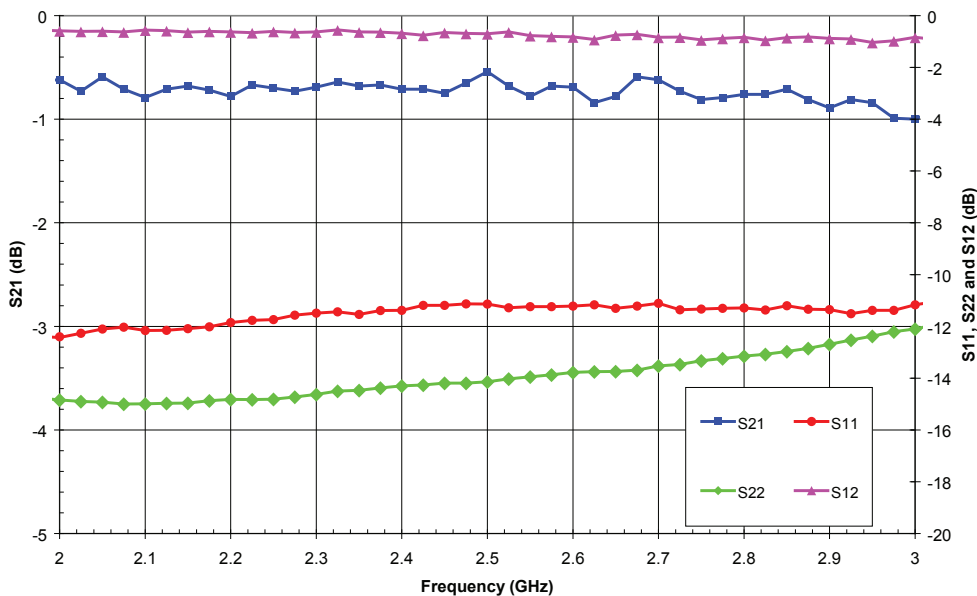

**Figure 8: 5 GHz Band EVM and Average Packet Current vs Modulated Output Power**  
 (T<sub>C</sub> = +25 °C, V<sub>CC</sub> = +3.3 V, PA<sub>ON5</sub> = +3.3 V, V<sub>TX5</sub> = +3.3 V, V<sub>RX5</sub> = 0 V) Static Mode 64 QAM OFDM 54 Mbps

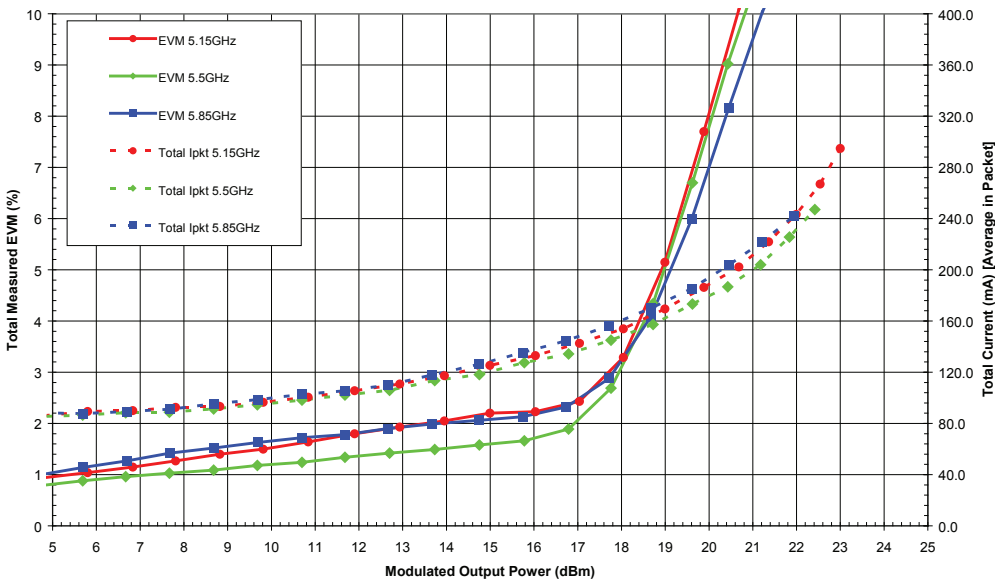

**Figure 9: 5 GHz Band Transducer Gain and Detector Voltage vs Modulated Output Power**  
 (T<sub>c</sub> = +25 °C, V<sub>CC</sub> = +3.3 V, PA<sub>ON5</sub> = +3.3 V, V<sub>TX5</sub> = +3.3 V, V<sub>RX5</sub> = 0 V)

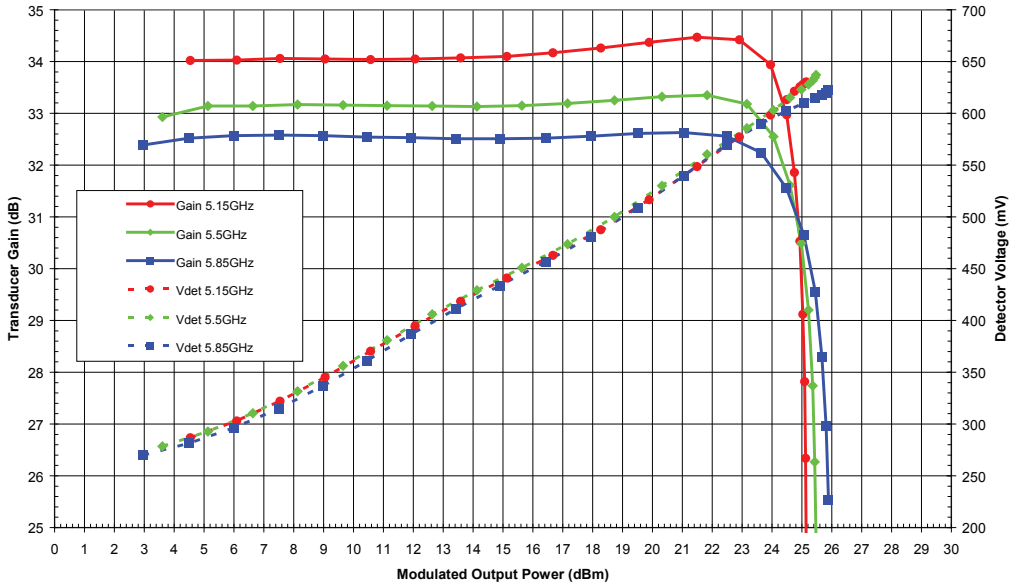

**Figure 10: 5 GHz Band Noise Figure vs Frequency**  
 (T<sub>c</sub> = +25 °C, V<sub>CC</sub> = +3.3 V, LNA<sub>ON5</sub> = +3.3 V, V<sub>RX5</sub> = +3.3 V, V<sub>TX5</sub> = 0 V)

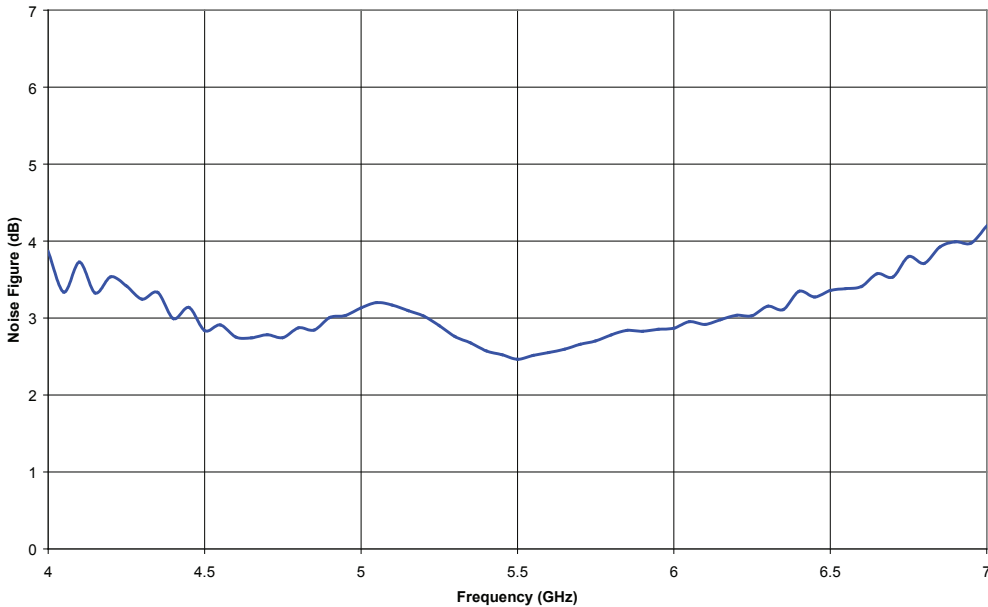

**Figure 11: 5 GHz Band RX Gain vs Frequency**  
( $T_C = +25\text{ }^\circ\text{C}$ ,  $V_{CC} = +3.3\text{ V}$ ,  $LNA_{ON5} = +3.3\text{ V}$ ,  $V_{RX5} = +3.3\text{ V}$ ,  $V_{TX5} = 0\text{ V}$ )

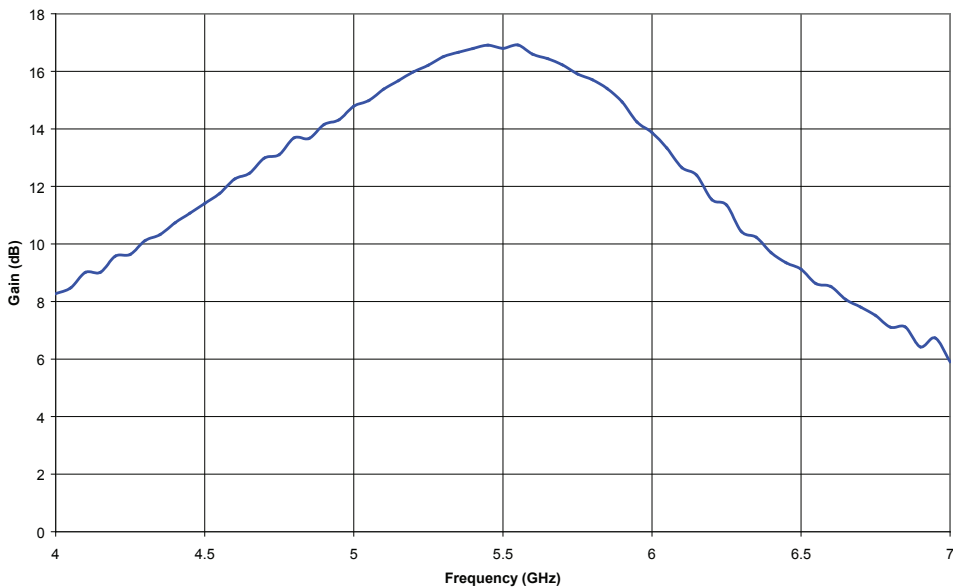

APPLICATION INFORMATION

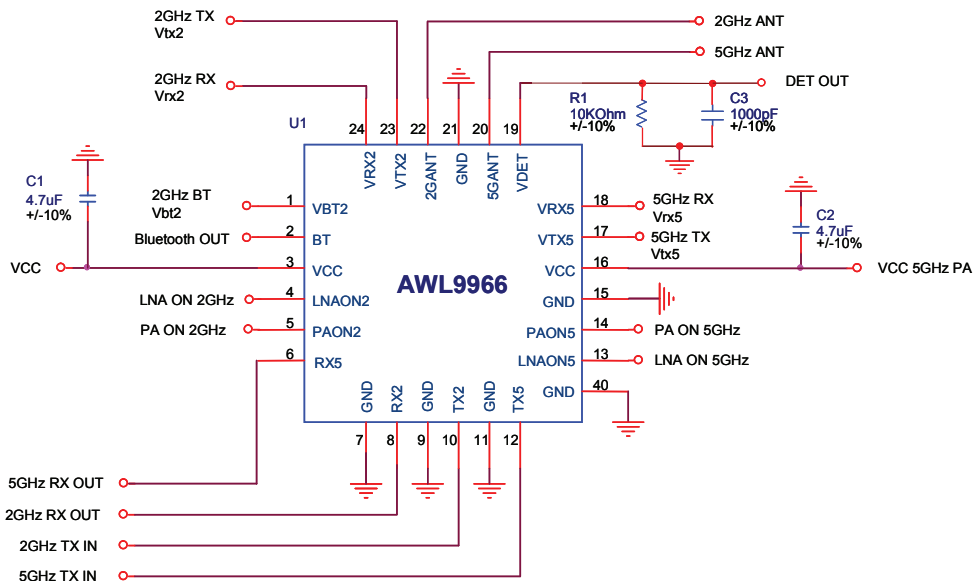

Figure 12: Application Circuit

Table 13: Switch Modes of Operation

MODES OF OPERATION	PAon2	PAon5	LNAon2	LNAon5	VBT2	VRx2	VTx2	VRx5	VTx5
TX 2 GHz	<b>HIGH</b>	LOW	LOW	LOW	LOW	LOW	<b>HIGH</b>	LOW	LOW
RX 2 GHz	LOW	LOW	<b>HIGH</b>	LOW	LOW	<b>HIGH</b>	LOW	LOW	LOW
2 GHz RX Bypass	LOW	LOW	LOW	LOW	LOW	<b>HIGH</b>	LOW	LOW	LOW
BT 2 GHz	LOW	LOW	LOW	LOW	<b>HIGH</b>	LOW	LOW	LOW	LOW
BT & Bypass 2 GHz	LOW	LOW	LOW	LOW	<b>HIGH</b>	<b>HIGH</b>	LOW	LOW	LOW
BT & Rx 2 GHz	LOW	LOW	<b>HIGH</b>	LOW	<b>HIGH</b>	<b>HIGH</b>	LOW	LOW	LOW
TX 5 GHz	LOW	<b>HIGH</b>	LOW	LOW	LOW	LOW	LOW	LOW	<b>HIGH</b>
RX 5 GHz	LOW	LOW	LOW	<b>HIGH</b>	LOW	LOW	LOW	<b>HIGH</b>	LOW
5 GHz RX Bypass	LOW	LOW	LOW	LOW	LOW	LOW	LOW	<b>HIGH</b>	LOW
Power High Reset	LOW	LOW	LOW	LOW	LOW	LOW	LOW	LOW	LOW

Notes:

Vcc = +3.0 V to +4.2 V; Logic State LOW = 0 V to +0.5 V; Logic State HIGH = +3.0 V to +4.2 V



PACKAGE OUTLINE

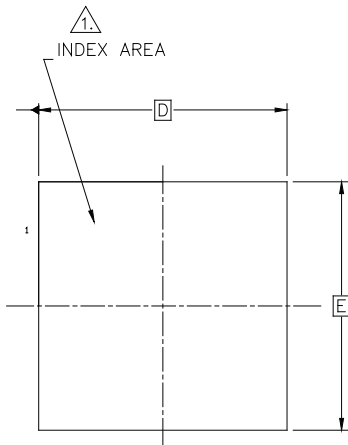

TOP VIEW

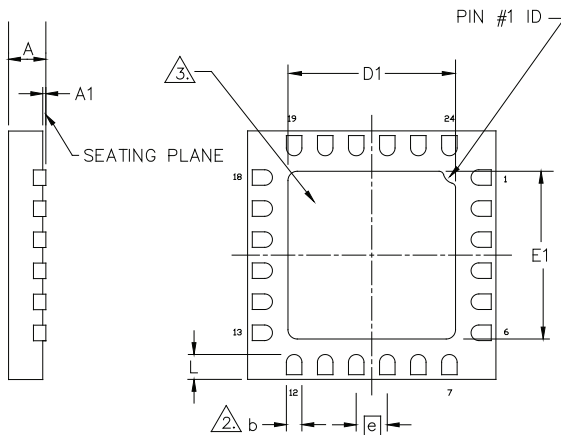

SIDE VIEW

BOTTOM VIEW

SYMBOL	DIMENSIONS—MM			NOTE
	MIN.	NOM.	MAX.	
A	0.50	0.55	0.60	
A1	0.00	0.02	0.05	
b	0.18	0.250	0.30	
D	4.00 BSC			
D1	2.55	2.70	2.80	
E	4.00 BSC			
E1	2.55	2.70	2.80	
e	0.50 BSC			
L	0.30	0.40	0.50	

NOTES :

- 1. TERMINAL #1 IDENTIFIER AND PAD NUMBERING CONVENTION SHALL CONFORM TO JESD 95-1 SPP-012.
- 2. DIMENSION b APPLIES TO METALLIZED TERMINAL AND IS MEASURED BETWEEN 0.25 AND 0.30mm FROM TERMINAL TIP.
- 3. BILATERAL COPLANARITY ZONE APPLIES TO THE EXPOSED PAD AS WELL AS THE TERMINALS.

Figure 13: S36 Package Outline - 24 Pin 4 mm x 4 mm x 0.55 mm QFN

## ORDERING INFORMATION

ORDER NUMBER	TEMPERATURE RANGE	PACKAGE DESCRIPTION	COMPONENT PACKAGING
AWL9966RS36P8	-40°C to +85°C	RoHS-Compliant 24 Pin 4 mm x 4 mm x 0.55 mm Surface Mount IC	2,500 piece Tape and Reel

**ANADIGICS, Inc.**

141 Mount Bethel Road  
Warren, New Jersey 07059, U.S.A.

Tel: +1 (908) 668-5000

Fax: +1 (908) 668-5132

URL: <http://www.anadigics.com>

E-mail: [Mktg@anadigics.com](mailto:Mktg@anadigics.com)

**IMPORTANT NOTICE**

ANADIGICS, Inc. reserves the right to make changes to its products or to discontinue any product at any time without notice. The product specifications contained in Advanced Product Information sheets and Preliminary Data Sheets are subject to change prior to a product's formal introduction. Information in Data Sheets have been carefully checked and are assumed to be reliable; however, ANADIGICS assumes no responsibilities for inaccuracies. ANADIGICS strongly urges customers to verify that the information they are using is current before placing orders.

**WARNING**

ANADIGICS products are not intended for use in life support appliances, devices or systems. Use of an ANADIGICS product in any such application without written consent is prohibited.