



Quad Small Form-factor Pluggable (QSFP) Products

DESCRIPTION

Tyco Electronics is a leading developer of Quad Small Form-factor Pluggable, a new high speed pluggable I/O interface. This interconnect system offers 4 channels, providing 3 times the density of SFP/SFP+ ports. QSFP cages and connectors are designed for data rates up to 10 Gb/s, supporting Fibre Channel, Ethernet, SDH/SONET and INFINIBAND standards. The cage/connector system will accept optical or copper interfaces.

APPLICATIONS

- Switches, routers, and host bus adapters (HBA's)
- Enterprise storage
- High density, high speed I/O
- Multiple channel interconnects

KEY FEATURES

- 4x solution featuring Tyco Electronics 38 position EVERCLEAR connector
- Lightpipe and heatsink options available
- Through-bezel and behind-bezel cage options with proven EMI containment
- Direct attach copper cables for short reach applications
- Quick release latching system
- MPO connectors plug into QSFP parallel optic transceiver modules

TECHNICAL DOCUMENTS

Product Specification: 108-2286

FOR MORE INFORMATION

Technical Support

Internet: <http://www.tycoelectronics.com>

USA: 1-800-522-6752

Canada: 1-905-470-4425

UK: 44-141-810-8967

Japan: 81-44-844-8013

Quad Small Form-factor Pluggable (QSFP) Products

PRODUCT APPLICATION

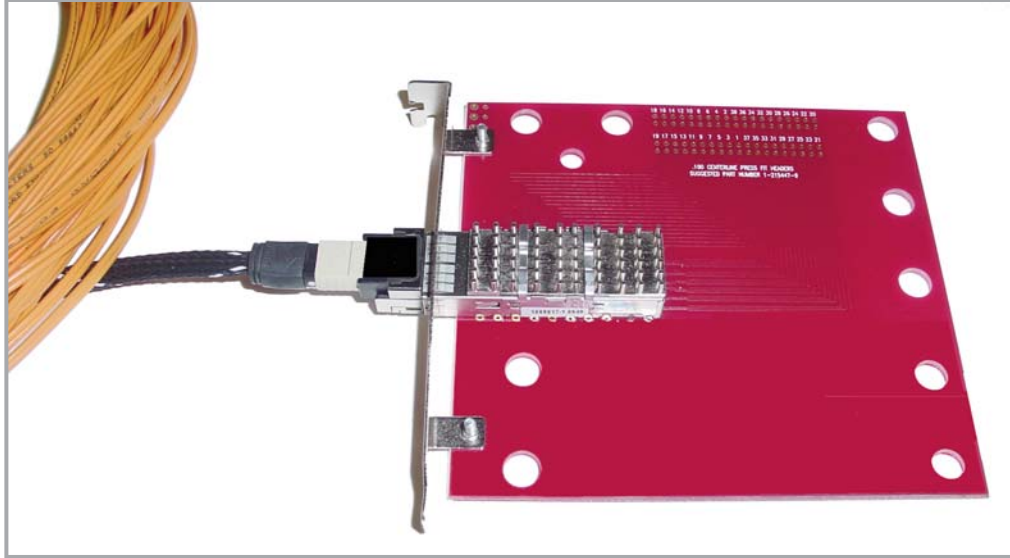

Connector/Cage Application

CONNECTOR

Part Number
1761987-9

- Tape and reel packaged for pick and place SMT processing
- 38 position EVERCLEAR connector
- Designed to optimize signal integrity through 10 Gb/s



Connector (front)



Connector (bottom)

Note: Part Numbers are RoHS Compliant.

CAGES

- Proven springs and gasket designs for EMI containment
- Single and dual lightpipes
- Riding heatsinks for thermal dissipation, various fin heights available
- Belly-to-belly compatible (double-sided PCB's)
- Press-fit termination
- Port-to port spacing-21.0mm (through-bezel)/23.5 (behind-bezel)



Quad Small Form-factor Pluggable (QSFP) Products

CAGES (Continued)

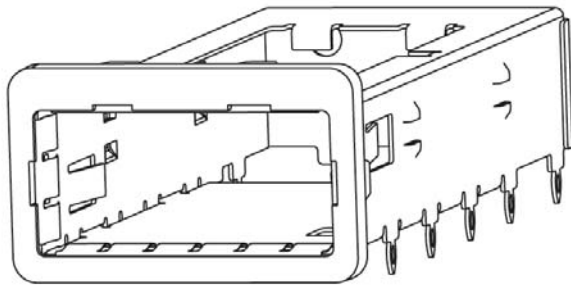

Behind-Bezel Cage

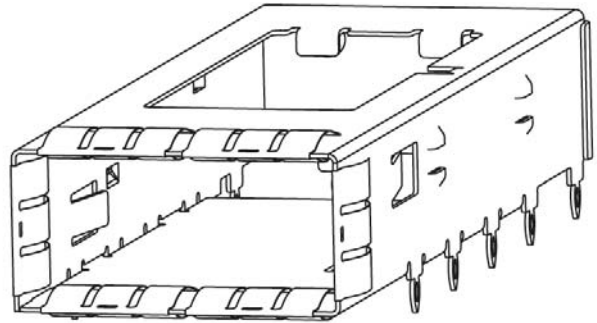

Through-Bezel Cage

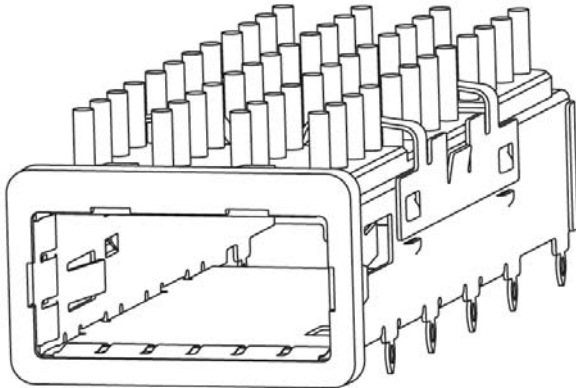

Behind-Bezel Cage with Heatsink

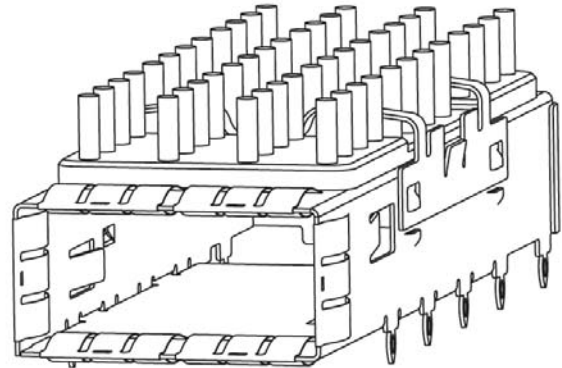

Through-Bezel Cage with Heatsink

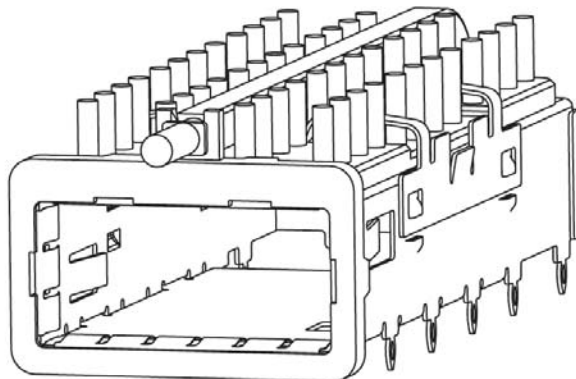

Behind-Bezel Cage with Heatsink and Lightpipe

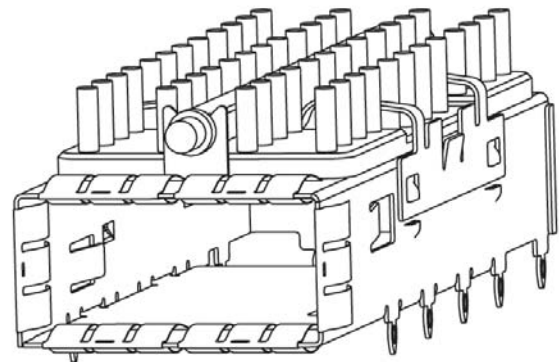

Through-Bezel Cage with Heatsink and Lightpipe

QSFP Cage Kits:

Part Number	Bezel Mount	Heatsink	Lightpipe
1888617-1	Through-bezel	None	None
1888674-1	Through-bezel	None	customer applied
1888631-1	Through-bezel	PCI	None
1888631-2	Through-bezel	SAN	None
1888631-3	Through-bezel	Networking	None
1888972-1	Through-bezel	SAN	Yes
1888972-2	Through-bezel	Networking	Yes
1888781-1	Behind-bezel	None	None
1888968-1	Behind-bezel	PCI	None
1888968-2	Behind-bezel	SAN	None
1888968-3	Behind-bezel	Networking	None

Note: Part Numbers are RoHS Compliant.

Quad Small Form-factor Pluggable (QSFP) Products

EMI/DUST PLUG

- Part Number: 1888810-2
- Provides EMI containment for unused ports
- Keeps interface free of contamination or debris
- Ergonomic Design



DIRECT ATTACH COPPER CABLE ASSEMBLIES

- Self-resetting latch, with ergonomic pull-tab for PCB protection
- Rugged stainless steel tab for PCB protection
- Cable wire size 28 or 26 AWG
- Active or passive equalization
- Various lengths available
- Breakout cables to SFP, CX4 and HSSDC2 are possible



Type	Part Number	Description
Passive	2015234-1	1 meter QSFP Cable Assembly
	2015234-2	2 meter QSFP Cable Assembly
	2015234-3	3 meter QSFP Cable Assembly
	2015234-4	4 meter QSFP Cable Assembly
	2015234-5	5 meter QSFP Cable Assembly
	2015234-6	6 meter QSFP Cable Assembly
	2015234-7	7 meter QSFP Cable Assembly
	2015234-8	8 meter QSFP Cable Assembly
Active	2015446-1	1 meter QSFP Cable Assembly
	2015446-2	2 meter QSFP Cable Assembly
	2015446-3	3 meter QSFP Cable Assembly
	2015446-4	4 meter QSFP Cable Assembly
	2015446-5	5 meter QSFP Cable Assembly
	2015446-6	6 meter QSFP Cable Assembly
	2015446-7	7 meter QSFP Cable Assembly
	2015446-8	8 meter QSFP Cable Assembly
	2015446-9	9 meter QSFP Cable Assembly
	2015446-10	10 meter QSFP Cable Assembly
	2015446-11	11 meter QSFP Cable Assembly
	2015446-12	12 meter QSFP Cable Assembly
	2015446-13	13 meter QSFP Cable Assembly
	2015446-14	14 meter QSFP Cable Assembly
	2015446-15	15 meter QSFP Cable Assembly

Note: Part Numbers are RoHS Compliant.

Quad Small Form-factor Pluggable (QSFP) Products

FIBER OPTIC CABLE ASSEMBLIES

QSFP Optical Jumper:

- Uses 50/125um MM fiber (500MHz-km BW at 850nm and 1300nm wavelengths) with OFNR-rated jacket
- Fiber path is reversed (1 to 12, 2 to 11, 3 to 10, 4 to 9, fibers 5, 6, 7, 8 not used)

Other options include:

- Custom lengths
- High bandwidth cable (up to 2000MHz-km)
- OFNP rated jacket
- Fanout to LC for interface to SFP optical ports

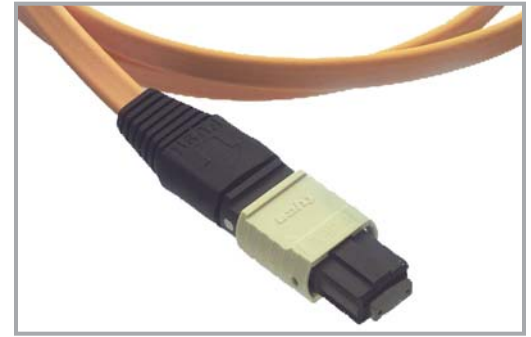

MPO to MPO suitable for interface to transceiver

Part Number	Standard Length
1938208-1	1m
1938208-5	5m
1-1938208-0	10m
2-1938208-0	20m
5-1938208-0	50m

Note: See drawing for part numbers of other standard lengths.

Note: Part Numbers are RoHS Compliant.

Restriction on the use of Hazardous Substances (RoHS)

At Tyco Electronics, we're ready to support your RoHS requirements. We've assessed more than 1.5 million end items/components for RoHS compliance, and issued new part numbers where any change was required to eliminate the restricted materials. Part numbers in this catalog are identified as:

RoHS Compliant — Part numbers in this catalog are RoHS Compliant, unless marked otherwise. These products comply with European Union Directive 2002/95/EC as amended 1January 2006 that restricts the use of lead, mercury, cadmium, hexavalent chromium, PBB, and PBDE in certain electrical and electronic products sold into the EU as of 1 July 2006.

NOTE: For purposes of this Catalog, included within the definition of RoHS Compliant are products that are clearly "Out of Scope" a of the RoHS Directive such as hand tools and other non-electrical accessories.

NOTE: Information regarding RoHS compliance is provided based on reasonable inquiry of our suppliers and represents our current actual knowledge based on the information provided by our suppliers. This information is subject to change. For latest compliance status, refer to our website referenced at right.

Getting the Information You Need

Our comprehensive on-line RoHS Customer Support Center provides a forum to answer your questions and support your RoHS needs. A RoHS FAQ (Frequently Asked Questions) is available with links to more detailed information. You can also submit RoHS questions and receive a response within 24hours during a normal work week.

The Support Center also provides:

- Cross-Reference from Non-compliant to Compliant Products
- Ability to browse RoHS Compliant Products in our on-line catalog
- Downloadable Technical Data Customer Information Presentation
- More detailed information regarding the definitions used above
- So whatever your questions when it comes to RoHS, we've got the answers at www.tycoelectronics.com/leadfree



Disclaimer

While Tyco Electronics Corporation and its affiliates referenced herein ("Tyco Electronics") have made every reasonable effort to ensure the accuracy of the information in this catalog, Tyco Electronics does not guarantee that it is error free, nor does Tyco Electronics make any other representation, warranty or guarantee that the information is accurate, correct reliable or current.

Tyco Electronics reserves the right to make any adjustments to the information contained herein at any time without notice. Tyco Electronics expressly disclaims all implied warranties regarding the information contained herein, including, but not limited to, any implied warranties of merchantability or fitness for a particular purpose. Tyco Electronics' only obligations are those in the Tyco Electronics Standard Terms and Conditions of Sale, and in no case will Tyco Electronics be responsible for any incidental, indirect, or consequential damages arising from the sale, resale, or misuse of its products. Users should independently evaluate the suitability of, and test each product for, their application.