

PLEASE CHECK WWW.MOLEX.COM FOR LATEST PART INFORMATION

Part Number: [0192210248](#)
Status: **Active**
Description: Compression Style Ring Tongue Terminal for 3/0 AWG Wire, Stud Size 1/2", Plated

Documents:

[Drawing \(PDF\)](#) [RoHS Certificate of Compliance \(PDF\)](#)

Agency Certification

CSA LR18689
 UL E32244

General

Product Family Ring and Spade Terminals
 Series [19221](#)
 Comments Heavy Duty
 Crimp Quality Equipment Yes
 Mil-Spec N/A
 Product Name Battery Cable Lug
 Type Ring

Physical

Barrel Type Closed
 Insulation None
 Material - Plating Mating Tin
 Packaging Type Bag
 Plating min: Mating (µin) 160
 Plating min: Mating (µm) 4
 Plating min: Termination (µin) 160
 Plating min: Termination (µm) 4
 Stud Size 1/2" (M12)
 Termination Interface: Style Crimp or Compression
 Wire Insulation Diameter N/A
 Wire Size AWG 3/0
 Wire Size mm² 76.20 - 96.30

Material Info

Old Part Number BCL-3012-PL

Reference - Drawing Numbers

Sales Drawing SD-19221-011

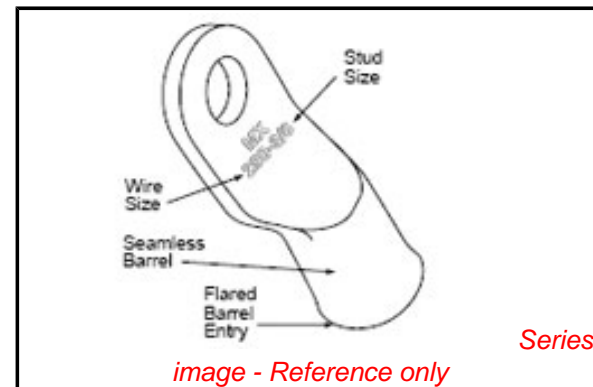

EU RoHS

ELV and RoHS Compliant

REACH SVHC

Contains SVHC: No

Halogen-Free

Status

Halogen-Free

China RoHS



Need more information on product environmental compliance?

Email productcompliance@molex.com
 For a multiple part number RoHS Certificate of Compliance, [click here](#)

Please visit the [Contact Us](#) section for any non-product compliance questions.

Search Parts in this Series

[19221Series](#)

Application Tooling | FAQ

Tooling specifications and manuals are found by selecting the products below. Crimp Height Specifications are then contained in the Application Tooling Specification document.

Global

Description	Product #
Putt Pump Dieless Head System	0192860065
Manual tool for Crimping non-insulated 8AWG thru 4/0 Terminals	0192940008
Manual Putt Pump Hydraulic System, Die set required	0192860117
Hand Crimp Tool	0192840034
Die Set (large) for the HHLS Hydraulic Crimper	0192900028

This document was generated on 04/14/2010

PLEASE CHECK WWW.MOLEX.COM FOR LATEST PART INFORMATION

13	12	11	10	9	8	7	6	5	4	3	2	1
UNPLATED MATERIAL NUMBER	UNPLATED ENG. NUMBER	PLATED MATERIAL NUMBER	PLATED ENGINEERING NUMBER	STUD SIZE	AWG WIRE RANGE	"S"	"L"	"W"	"C"	"B"	"T"	
J 1922 10423	BCL-1014	1922 10422	BCL-1014-PL	1/4/(6.4)	1/0	.278/(7.06)	1.844/(46.84)	.718/(18.24)	.460/(11.68)	.400/(10.16)	.110/(2.80)	
1922 10394	BCL-10516	1922 10240	BCL-10516-PL	5/16/(7.9)	1/0	.340/(8.64)	1.844/(46.84)	.718/(18.24)	.460/(11.68)	.400/(10.16)	.110/(2.80)	
1922 10377	BCL-1038	1922 10241	BCL-1038-PL	3/8/(9.5)	1/0	.400/(10.16)	1.844/(46.84)	.718/(18.24)	.460/(11.68)	.400/(10.16)	.110/(2.80)	
1922 10441	BCL-1038-WP	1922 10440	BCL-1038-WP-PL	3/8/(9.5)	1/0	.400/(10.16)	1.906/(48.41)	.813/(20.65)	.442/(11.23)	.400/(10.16)	.110/(2.80)	
1922 10393	BCL-1012	1922 10242	BCL-1012-PL	1/2/(12.7)	1/0	.520/(13.21)	1.844/(46.84)	.718/(18.24)	.460/(11.68)	.400/(10.16)	.110/(2.80)	
1922 10437	BCL-1012-WP	1922 10436	BCL-1012-WP-PL	1/2/(12.7)	1/0	.520/(13.21)	1.906/(48.41)	.813/(20.65)	.442/(11.23)	.400/(10.16)	.110/(2.80)	
I 1922 10249	BCL-2014	1922 10234	BCL-2014-PL	1/4/(6.4)	2/0	.278/(7.06)	2.062/(52.37)	.824/(20.93)Ⓣ	.522/(13.26)	.461/(11.71)	.110/(2.80)	
1922 10398	BCL-20516	1922 10243	BCL-20516-PL	5/16/(7.9)	2/0	.340/(8.64)	2.062/(52.37)	.824/(20.93)Ⓣ	.522/(13.26)	.461/(11.71)	.110/(2.80)	
1922 10379	BCL-2038	1922 10244	BCL-2038-PL	3/8/(9.5)	2/0	.400/(10.16)	2.062/(52.37)	.824/(20.93)Ⓣ	.522/(13.26)	.461/(11.71)	.110/(2.80)	
1922 10397	BCL-2012	1922 10245	BCL-2012-PL	1/2/(12.7)	2/0	.520/(13.21)	2.062/(52.37)	.824/(20.93)Ⓣ	.522/(13.26)	.461/(11.71)	.110/(2.80)	
1922 10597	BCL-2058	1922 10598	BCL-2058-PL	5/8/(15.9)	2/0	.656/(16.66)	2.062/(52.37)	.824/(20.93)Ⓣ	.522/(13.26)	.461/(11.71)	.110/(2.80)	
1922 10478	BCL-3014	1922 10570	BCL-3014-PL	1/4/(6.4)	3/0	.278/(7.06)	2.156/(54.76)	.916/(23.27)Ⓣ	.501/(12.73)	.511/(12.93)	.115/(2.92)	
H 1922 10402	BCL-30516	1922 10246	BCL-30516-PL	5/16/(7.9)	3/0	.340/(8.64)	2.156/(54.76)	.916/(23.27)Ⓣ	.501/(12.73)	.511/(12.93)	.115/(2.92)	
1922 10381	BCL-3038	1922 10247	BCL-3038-PL	3/8/(9.5)	3/0	.400/(10.16)	2.156/(54.76)	.916/(23.27)Ⓣ	.501/(12.73)	.511/(12.93)	.115/(2.92)	
1922 10401	BCL-3012	1922 10248	BCL-3012-PL	1/2/(12.7)	3/0	.520/(13.21)	2.156/(54.76)	.916/(23.27)Ⓣ	.501/(12.73)	.511/(12.93)	.115/(2.92)	
1922 10502	BCL-40516(.625)	1922 10503	BCL-40516-PL(.625)	5/16/(7.9)	4/0	.340/(8.63)	2.688/(68.28)	1.094/(27.78)	.557/(14.15)	.625/(15.88)	.135/(3.43)	
1922 10374	BCL-4038(.625)	1922 10371	BCL-4038-PL(.625)	3/8/(9.5)	4/0	.400/(10.16)	2.688/(68.28)	1.094/(27.78)	.557/(14.15)	.625/(15.88)	.135/(3.43)	
1922 10375	BCL-4012(.625)	1922 10372	BCL-4012-PL(.625)	1/2/(12.7)	4/0	.520/(13.21)	2.688/(68.28)	1.094/(27.78)	.557/(14.15)	.625/(15.88)	.135/(3.43)	
1922 10413	BCL-40516	1922 10412	BCL-40516-PL	5/16/(7.9)	4/0	.340/(8.63)	2.344/(59.54)	.984/(24.99)	.550/(13.97)	.559/(14.20)	.135/(3.43)	
G 1922 10382	BCL-4038	1922 10250	BCL-4038-PL	3/8/(9.5)	4/0	.400/(10.16)	2.344/(59.54)	.984/(24.99)	.550/(13.97)	.559/(14.20)	.135/(3.43)	
1922 10403	BCL-4012	1922 10251	BCL-4012-PL	1/2/(12.7)	4/0	.520/(13.21)	2.344/(59.54)	.984/(24.99)	.550/(13.97)	.559/(14.20)	.135/(3.43)	
1922 10446	BCL-25038	1922 10447	BCL-25038-PL	3/8/(9.5)	250	.400/(10.16)	2.656/(67.46)	1.203/(30.56)	.676/(17.17)	.685/(17.40)	.125/(3.18)	
1922 10652	BCL-4014	1922 10648	BCL-4014-PL	1/4/(6.4)	4/0	.278/(7.061)	2.344/(59.54)	.984/(24.99)	.550/(13.97)	.559/(13.97)	.135/(3.43)	

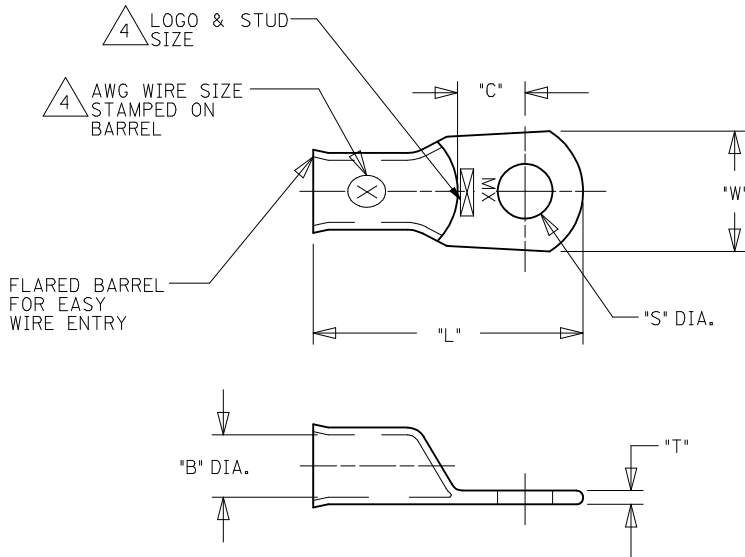

SALES DRAWING

NOTES:

- FOR INSPECTION SIGHT HOLE, PLEASE CONSULT FACTORY.
- OTHER STUD SIZES MAY BE AVAILABLE, PLEASE CONSULT FACTORY.
- MATERIAL: COPPER
PLATING: TIN
- MARKINGS CAN BE AT EITHER LOCATION SHOWN.
- IF TONGUE IS TO BE BENT AT ANY ANGLE, IT MUST BE BENT AROUND A RADIUS ONE HALF THE TONGUE THICKNESS.
- USE .625/(15.88) BARREL I.D. FOR HIGH STRAND WELDING CABLE.

TONGUE WIDTH 2/0,3/0 EC NO: MNA2009-0341 DRW: WETHRODAHL 2009/07/27 CHKD: JMACNEIL 2009/08/11 APPR: JMACNEIL 2009/08/11	QUALITY SYMBOLS ▽=0 ▽=0	GENERAL TOLERANCES (UNLESS SPECIFIED)		DIMENSION STYLE IN/MM		SCALE --	DESIGN UNITS INCH	THIRD ANGLE PROJECTION		
		mm	INCH	DRAWN BY BRE	DATE 2002/06/24	BATTERY CABLE LUG COPPER TERMINALS 1/0, 2/0, 3/0 & 4/0				
		4 PLACES ±---	±---	CHECKED BY HEB	DATE 2002/06/24					
		3 PLACES ±---	±.005	APPROVED BY RWD		DATE 2002/06/24	MOLEX INCORPORATED MATERIAL NO. SEE CHART DOCUMENT NO. SD-19221-011			
2 PLACES ±0.13	±.01	DRAFT WHERE APPLICABLE MUST REMAIN WITHIN DIMENSIONS		SIZE C	THIS DRAWING CONTAINS INFORMATION THAT IS PROPRIETARY TO MOLEX INCORPORATED AND SHOULD NOT BE USED WITHOUT WRITTEN PERMISSION					
1 PLACE ±0.25	±---									SHEET NO. 1 OF 1
ANGULAR ±---										