

Technical Data Sheet (Preliminary)**Luminosity Full Color LED****93-23/R6SGHB7C-A02/2T****Features**

- Super-luminosity chip LED.
- White SMT package.
- Built in Red, Green, and Blue chips.
- Lead frame package with individual 6 pins.
- Wide viewing angle.
- Soldering methods: IR reflow soldering.
- Pb-free.
- The product itself will remain within RoHS compliant version.

**Descriptions**

- Due to the package design, 93-23 has low power consumption and adjusting each color is possible thanks to serial connection by 6 terminal connection (Individual driving by each terminal) in case of using several number of LED. And makes it ideal for light pipe application.

Applications

- Amusement equipment.
- Information boards.
- Flashlight for digital camera of cellular phone.

Device Selection Guide

Chip			Lens Color
Type	Material	Emitted Color	
R6S	AlGaInP	Brilliant Red	Water Clear
GH	InGaN	Brilliant Green	
B7	InGaN	Blue	

93-23/R6SGHB7C-A02/2T

Package Outline Dimensions

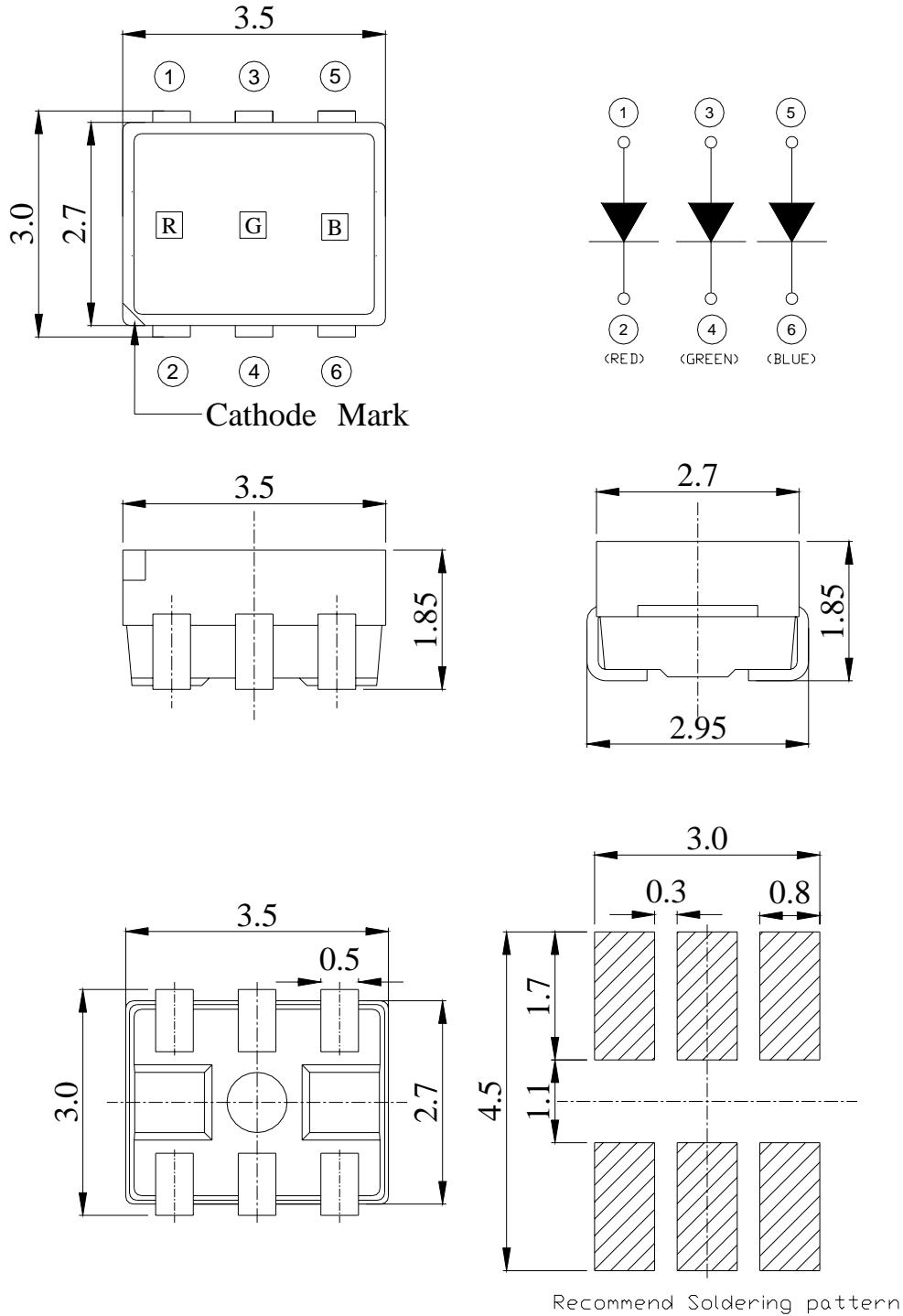

- Notes:**
- 1.All dimensions are in millimeters.
 - 2.Tolerances unspecified are ± 0.1 mm.

Absolute Maximum Ratings (Ta=25°C)

Parameter	Symbol	Rating		Unit
Reverse Voltage	V _R	5		V
Forward Current	I _F	R6S	50	mA
		GH	25	
		B7	30	
Peak Forward Current (Duty 1/10 @ 1KHz)	I _{FP}	R6S	100	mA
		GH	100	
		B7	100	
Power Dissipation	P _d	R6S	120	mW
		GH	110	
		B7	110	
Electrostatic Discharge(HBM)	ESD	R6S	2000	V
		GH	150	
		B7	150	
Operating Temperature	T _{opr}	-40 ~ +85		°C
Storage Temperature	T _{stg}	-40~ +90		°C
Soldering Temperature	T _{sol}	Reflow Soldering : 260 °C for 10 sec. Hand Soldering : 350 °C for 3 sec.		

Electro-Optical Characteristics (Ta=25°C)

Parameter	Symbol	Min.	Typ.	Max.	Unit	Condition
Luminous Intensity	I _v	R6S	180	265	-----	mcd I _F =20mA
		GH	715	1010	-----	
		B7	140	240	-----	
Viewing Angle	2θ _{1/2}	-----	120	-----	deg	I _F =20mA
Peak Wavelength	λ _p	R6S	-----	632	-----	nm I _F =20mA
		GH	-----	518	-----	
		B7	-----	468	-----	
Dominant Wavelength	λ _d	R6S	-----	624	-----	nm I _F =20mA
		GH	-----	525	-----	
		B7	-----	470	-----	
Spectrum Radiation Bandwidth	Δλ	R6S	-----	20	-----	nm I _F =20mA
		GH	-----	35	-----	
		B7	-----	35	-----	
Forward Voltage	V _F	R6S	-----	2.0	2.4	V I _F =20mA
		GH	-----	3.3	3.7	
		B7	-----	3.3	3.7	
Reverse Current	I _R	R6S	-----	-----	10	μA V _R =5V
		GH	-----	-----	50	
		B7	-----	-----	50	

93-23/R6SGHB7C-A02/2T

Typical Electro-Optical Characteristics Curves (Red)

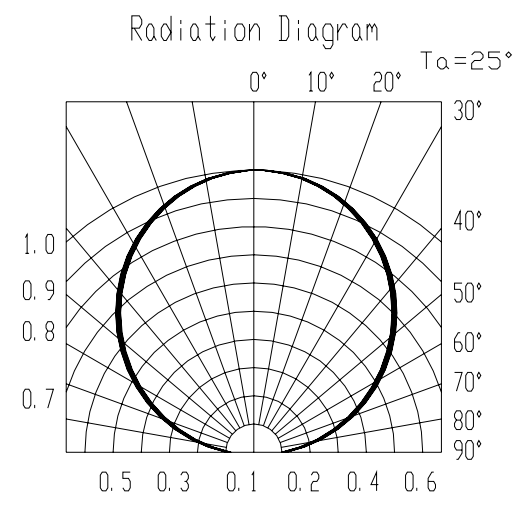
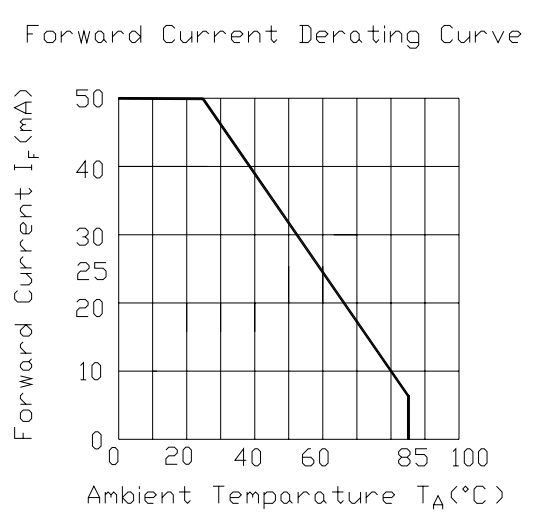
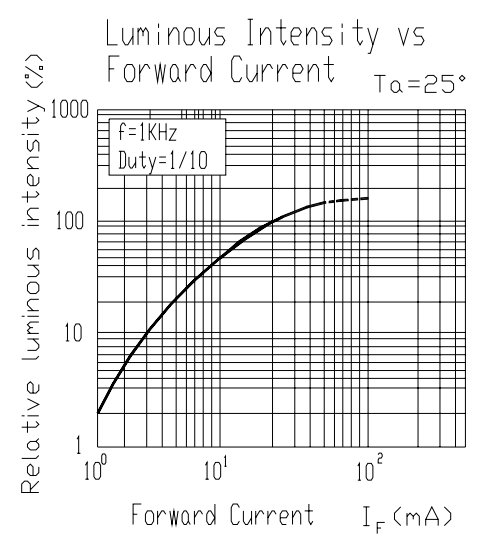
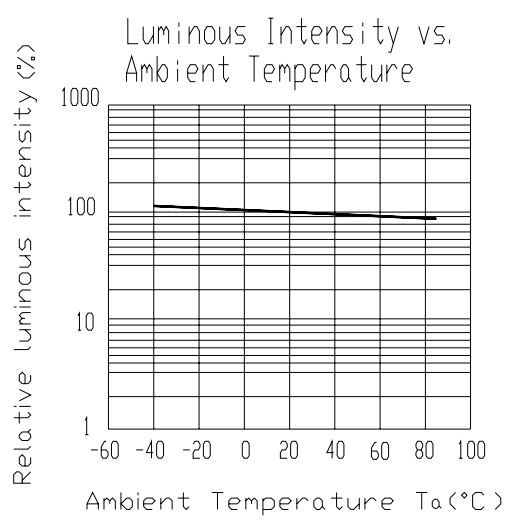
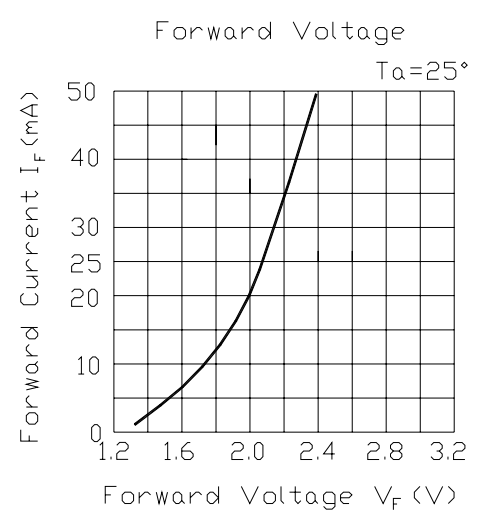
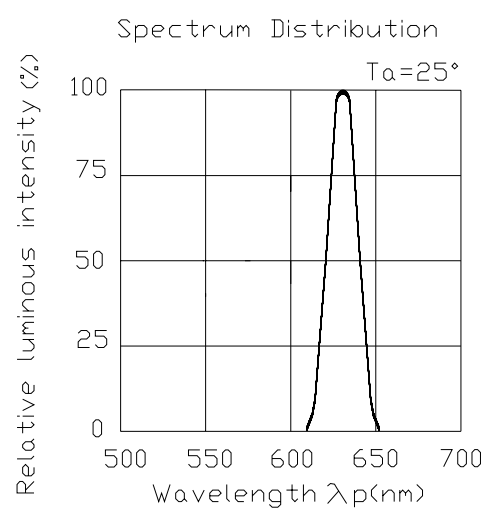

93-23/R6SGHB7C-A02/2T

Typical Electro-Optical Characteristics Curves (Green)

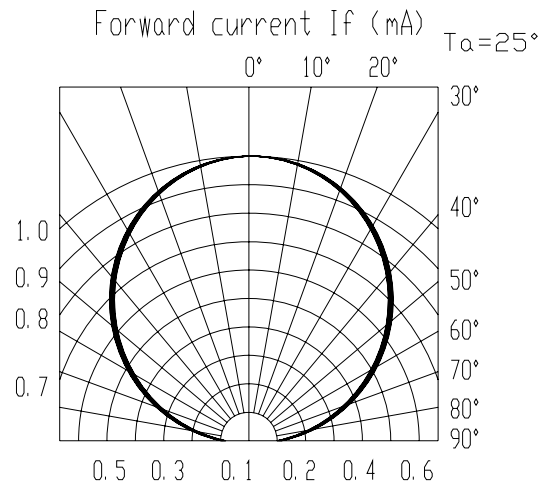
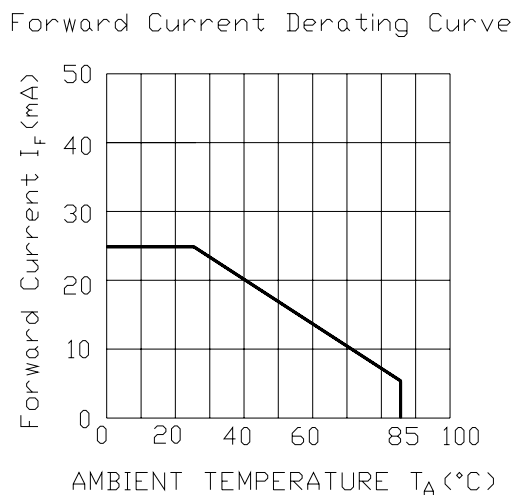
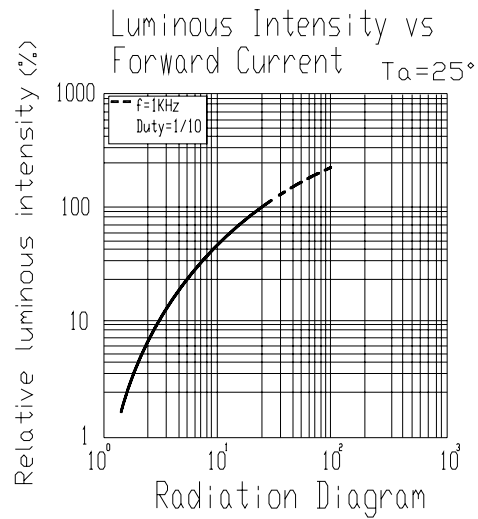
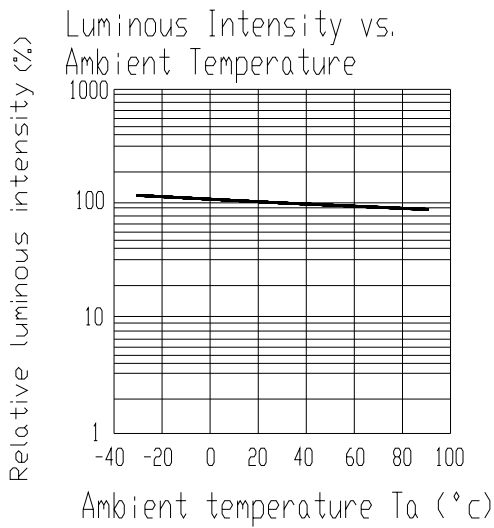
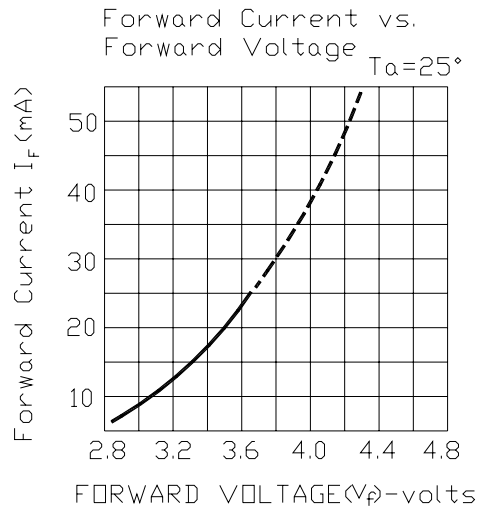
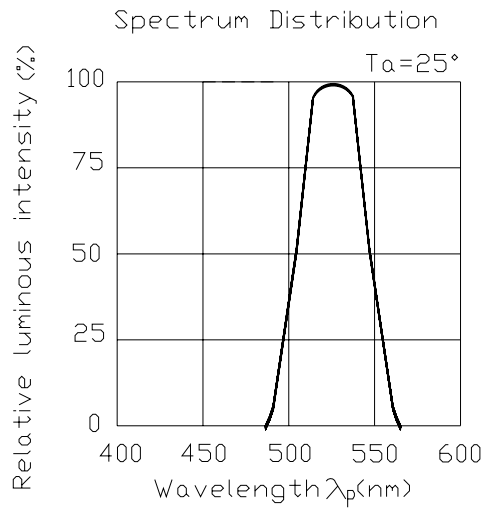

Typical Electro-Optical Characteristics Curves (Blue)

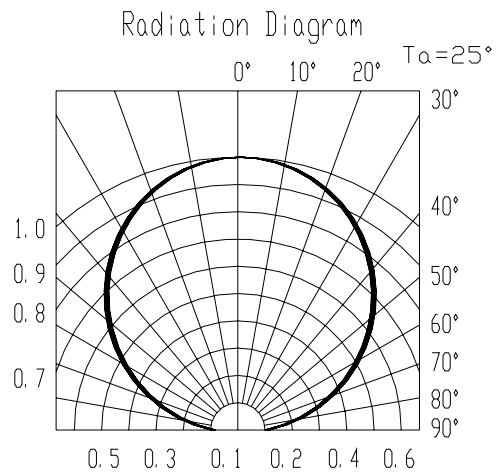
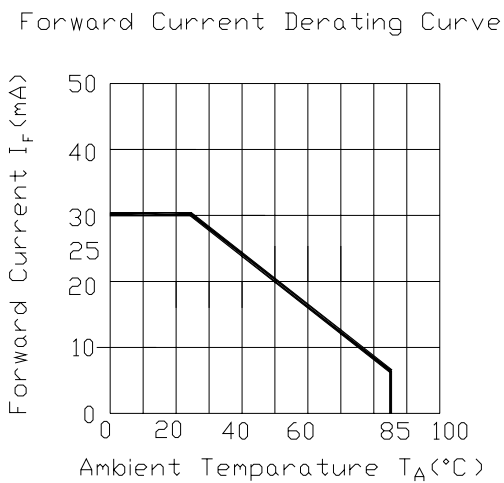
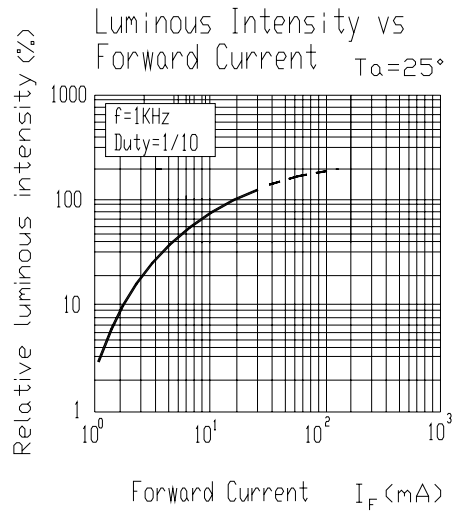
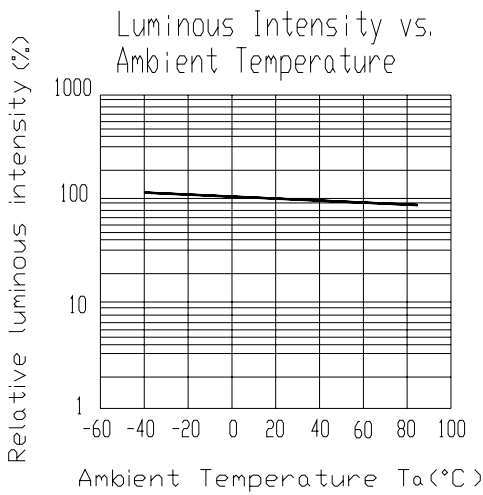
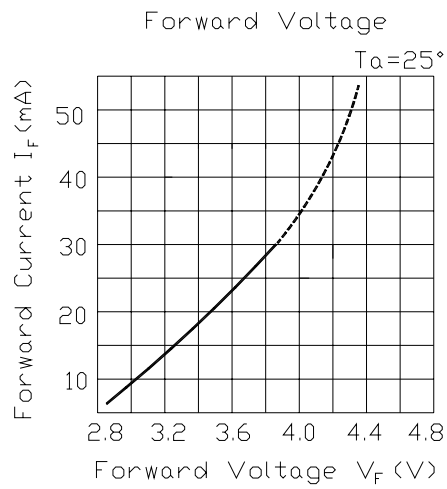
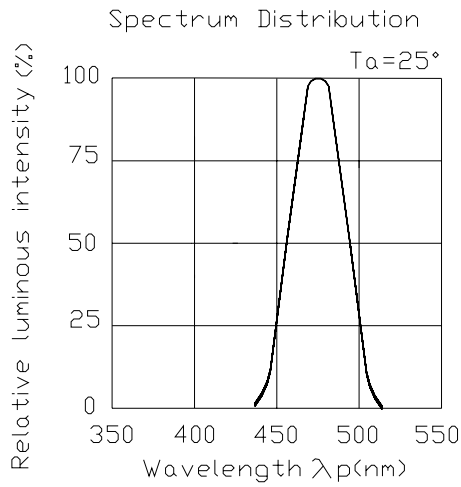

Label explanation

CAT: Luminous Intensity Rank

HUE: Dom. Wavelength Rank

REF: Forward Voltage Rank

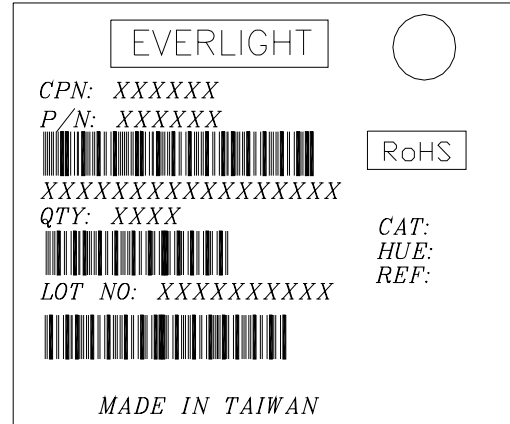

Reel Dimensions

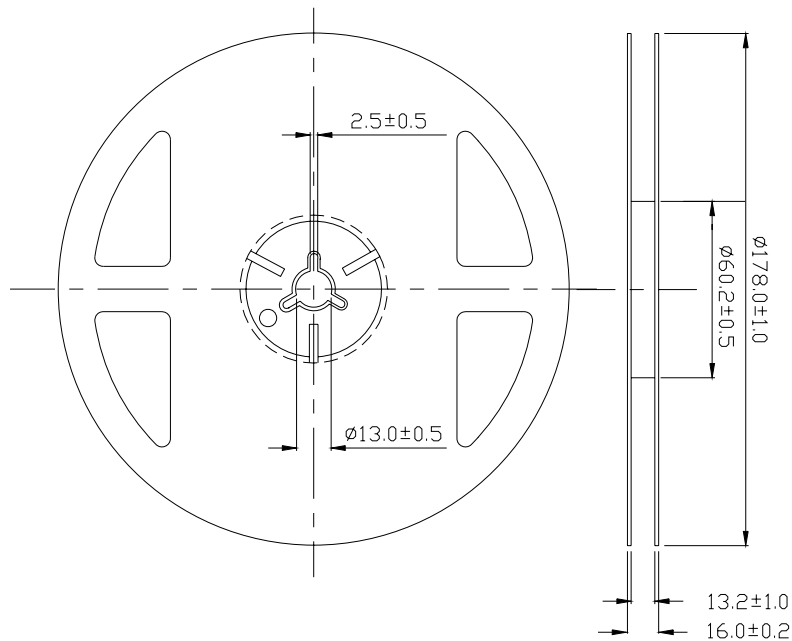

Note: The tolerances unless mentioned is $\pm 0.1\text{mm}$,Unit = mm

Carrier Tape Dimensions: Loaded quantity 2000 PCS per reel.

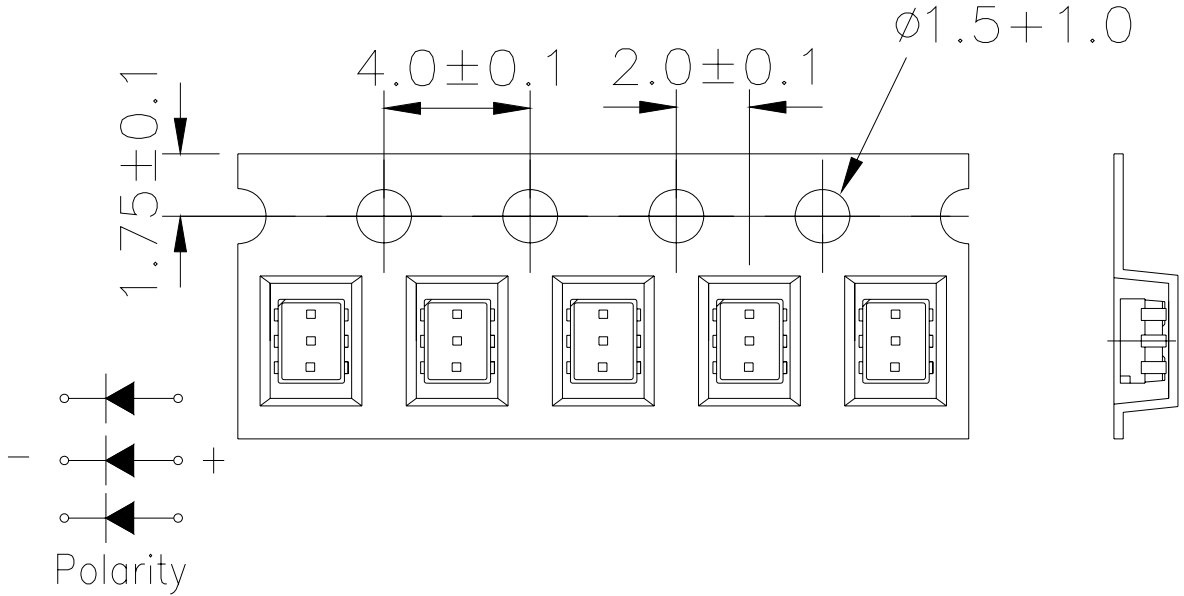

Note: The tolerances unless mentioned is ± 0.1 mm Unit = mm

Moisture Resistant Packaging

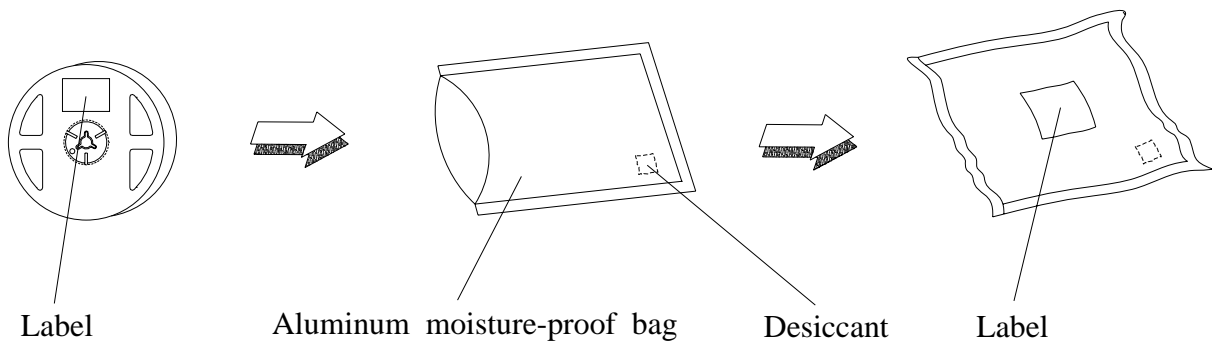

Reliability Test Items And Conditions

The reliability of products shall be satisfied with items listed below.

Confidence level : 90%

LTPD : 10%

No.	Items	Test Condition	Test Hours/Cycles	Sample Size	Ac/Re
1	Reflow Soldering	Temp. : 260°C±5°C Min. 5sec.	6 Min.	22 PCS.	0/1
2	Temperature Cycle	H : +100°C 15min ∫ 5 min L : -40°C 15min	300 Cycles	22 PCS.	0/1
3	Thermal Shock	H : +100°C 5min ∫ 10 sec L : -10°C 5min	300 Cycles	22 PCS.	0/1
4	High Temperature Storage	Temp. : 100°C	1000 Hrs.	22 PCS.	0/1
5	Low Temperature Storage	Temp. : -40°C	1000 Hrs.	22 PCS.	0/1
6	DC Operating Life	IF = 20 mA	1000 Hrs.	22 PCS.	0/1
7	High Temperature / High Humidity	85°C / 85%RH	1000 Hrs.	22 PCS.	0/1

Precautions For Use

1. Over-current-proof

Customer must apply resistors for protection , otherwise slight voltage shift will cause big current change (Burn out will happen).

2. Storage

2.1 Do not open moisture proof bag before the products are ready to use.

2.2 Before opening the package: The LEDs should be kept at 30°C or less and 90%RH or less.

2.3 After opening the package: The LED's floor life is 1 year under 30 deg C or less and 60% RH or less.

If unused LEDs remain, it should be stored in moisture proof packages.

2.4 If the moisture absorbent material (silica gel) has faded away or the LEDs have exceeded the storage time, baking treatment should be performed using the following conditions.

Baking treatment : 60±5°C for 24 hours.

3. Soldering Condition

3.1 Pb-free solder temperature profile

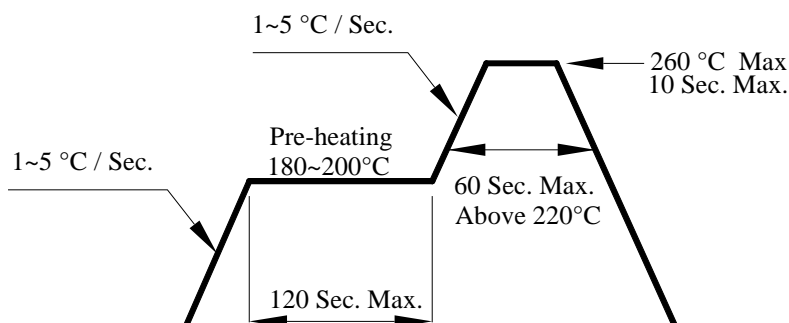

3.2 Reflow soldering should not be done more than two times.

3.3 When soldering, do not put stress on the LEDs during heating.

3.4 After soldering, do not warp the circuit board.

4.Soldering Iron

Each terminal is to go to the tip of soldering iron temperature less than 350°C for 3 seconds within once in less than the soldering iron capacity 25W. Leave two seconds and more intervals, and do soldering of each terminal. Be careful because the damage of the product is often started at the time of the hand solder.

5.Repairing

Repair should not be done after the LEDs have been soldered. When repairing is unavoidable, a double-head soldering iron should be used (as below figure). It should be confirmed beforehand whether the characteristics of the LEDs will or will not be damaged by repairing.

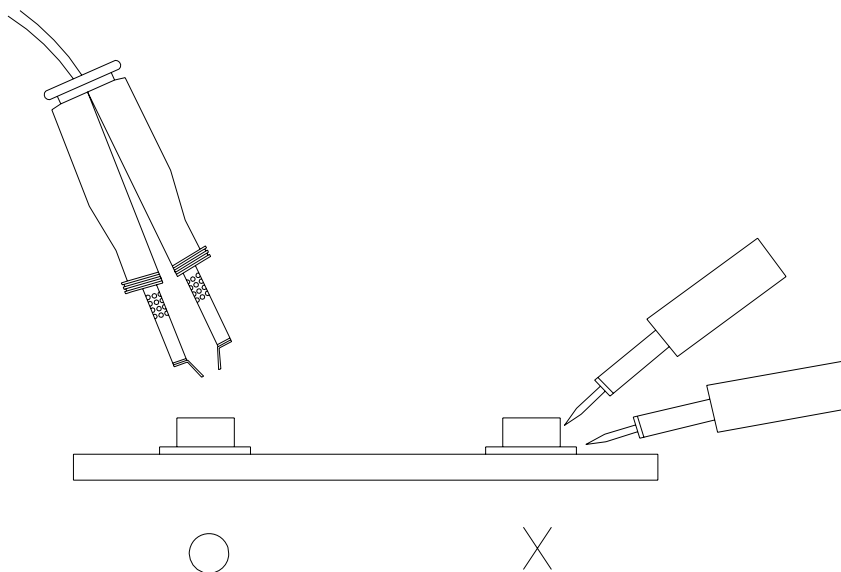

EVERLIGHT ELECTRONICS CO., LTD.
Office: No 25, Lane 76, Sec 3, Chung Yang Rd,
Tucheng, Taipei 236, Taiwan, R.O.C

Tel: 886-2-2267-2000, 2267-9936
Fax: 886-2267-6244, 2267-6189, 2267-6306
<http://www.everlight.com>