

PLEASE CHECK WWW.MOLEX.COM FOR LATEST PART INFORMATION

Part Number: [0678005001](#)
Status: **Active**
Overview: [serial_ata_products](#)
Description: 1.27mm (.050") Pitch Serial ATA High Speed Header, Vertical, Surface Mount, with Locking Latch, 7 Circuits, Gold (Au) Flash, for 1.60mm (.063") PCB, with PCB Locator Pegs, Lead-free

Documents:

[3D Model](#) [RoHS Certificate of Compliance \(PDF\)](#)
[Drawing \(PDF\)](#)

Agency Certification

CSA LR 19980
 UL E29179

General

Product Family PCB Headers
 Series [67800](#)
 Application Board-to-Board, Wire-to-Board
 Comments Staggered Solder Pin|Metal Post Length 2.65mm (.104")
 Overview [serial_ata_products](#)
 Product Name Serial ATA

Physical

Breakaway No
 Circuits (Loaded) 7
 Circuits (maximum) 7
 Color - Resin Black
 Durability (mating cycles max) 50
 First Mate / Last Break Yes
 Flammability 94V-0
 Glow-Wire Compliant No
 Guide to Mating Part No
 Keying to Mating Part Yes
 Lock to Mating Part Yes
 Material - Metal Brass
 Material - Plating Mating Gold
 Material - Plating Termination Tin
 Material - Resin High Temperature Thermoplastic
 Number of Rows 1
 Orientation Vertical
 PCB Locator Yes
 PCB Retention Yes
 Packaging Type Tray
 Pitch - Mating Interface (in) 0.050 In
 Pitch - Mating Interface (mm) 1.27 mm
 Pitch - Term. Interface (in) 0.050 In
 Pitch - Term. Interface (mm) 1.27 mm
 Plating min: Mating (µin) 2
 Plating min: Mating (µm) 0.05
 Plating min: Termination (µin) 75
 Plating min: Termination (µm) 1.9
 Polarized to Mating Part Yes
 Polarized to PCB Yes
 Shrouded Fully
 Stackable No

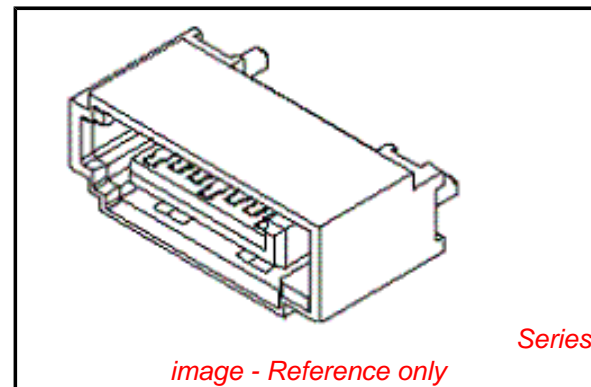

EU RoHS

ELV and RoHS Compliant
REACH SVHC
 Not Reviewed
Halogen-Free Status

China RoHS



Halogen-Free

Need more information on product environmental compliance?

Email productcompliance@molex.com
 For a multiple part number RoHS Certificate of Compliance, [click here](#)

Please visit the [Contact Us](#) section for any non-product compliance questions.

Search Parts in this Series
[67800Series](#)

Temperature Range - Operating -35°C to +85°C
Termination Interface: Style Surface Mount

Electrical

Current - Maximum per Contact 1.5A
Voltage - Maximum 15V DC

Solder Process Data

Lead-free Process Capability Reflow Capable (SMT only)

Material Info

Reference - Drawing Numbers

Packaging Specification PK-67800-001
Sales Drawing SD-67800-005

This document was generated on 05/26/2010

PLEASE CHECK WWW.MOLEX.COM FOR LATEST PART INFORMATION

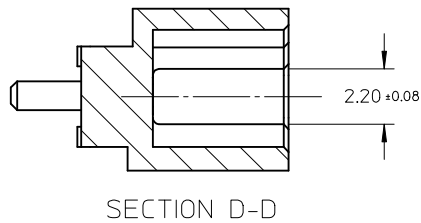
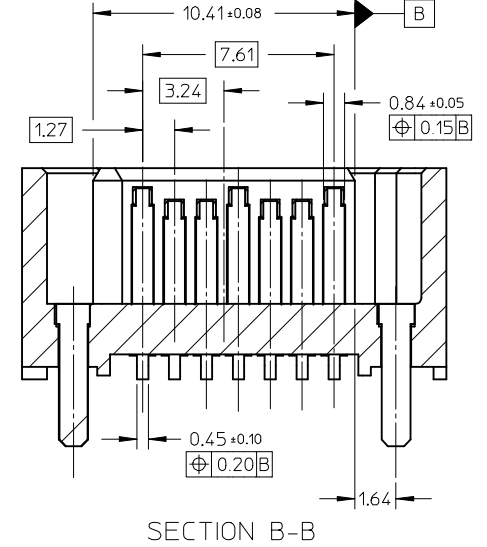
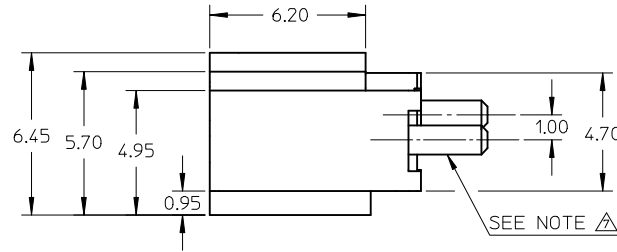
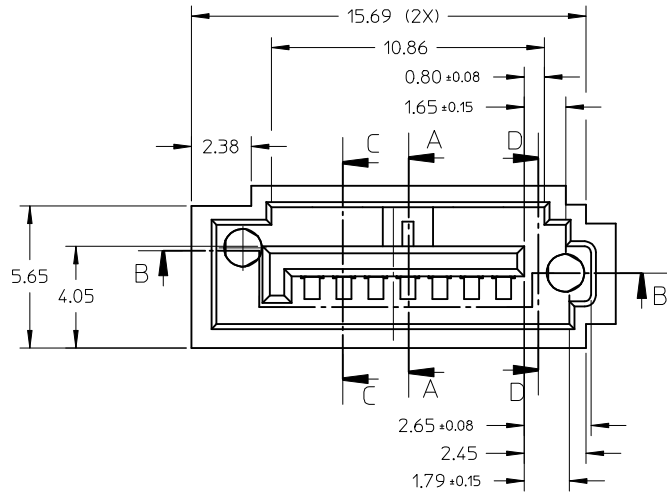
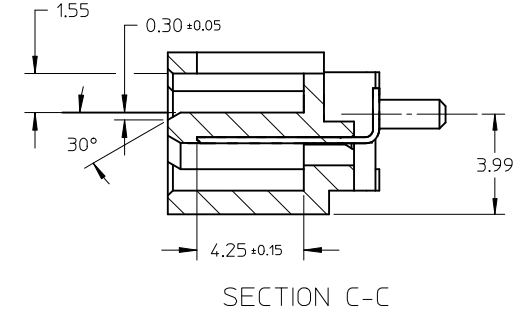
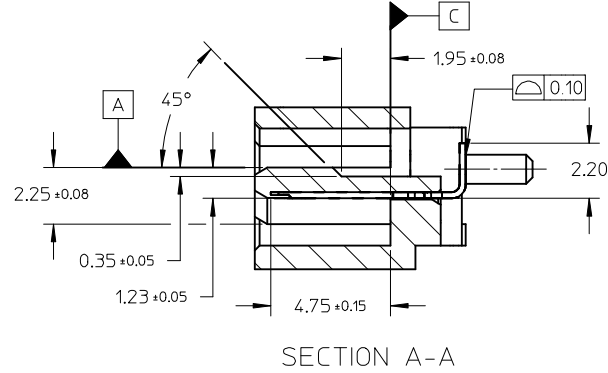
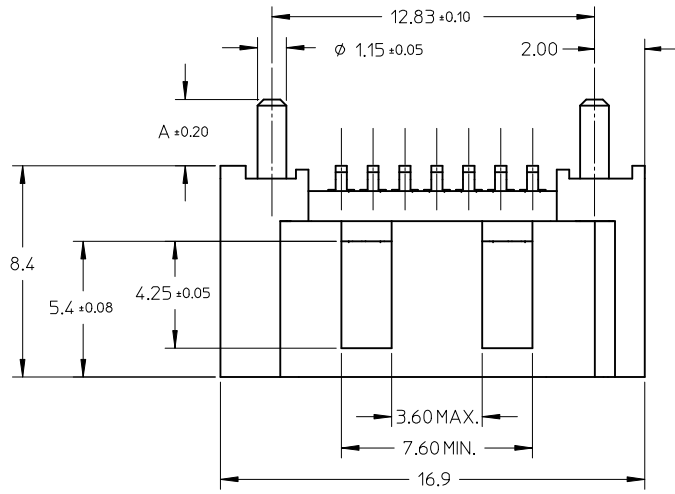

REVISED EC NO: SH2010-0043 TDRW:GLL 2009/08/07 CHKD:XJSONG 2009/08/10 APPR:RZHANG 2009/09/13	QUALITY SYMBOLS ▽=0 C=0	GENERAL TOLERANCES (UNLESS SPECIFIED)		DIMENSION STYLE MM ONLY		SCALE 5:1	DESIGN UNITS METRIC	THIRD ANGLE PROJECTION	
		4 PLACES ± --- ± ---	mm INCH	DRAWN BY GRATE MA	DATE 2004/02/02	TITLE HIGH SPEED CONNECTOR 1.27MM PITCH VERTICAL SMT SOLDER TAIL			
		3 PLACES ± --- ± ---		CHECKED BY YA JUN	DATE 2004/02/02	MOLEX INCORPORATED			
		2 PLACES ± 0.15 ± --- 1 PLACE ± 0.25 ± --- ANGULAR ± 1°		APPROVED BY SAM	DATE 2004/02/02	MATERIAL NO. SEE SHEET 2	DOCUMENT NO. SD-67800-005	SHEET NO. 1 OF 2	
DRAFT WHERE APPLICABLE MUST REMAIN WITHIN DIMENSIONS		THIS DRAWING CONTAINS INFORMATION THAT IS PROPRIETARY TO MOLEX INCORPORATED AND SHOULD NOT BE USED WITHOUT WRITTEN PERMISSION							

NOTES:

1. MATERIAL:

HOUSING: HIGH TEMPERATURE THERMAL PLASTIC, GLASS FILLED,
UL94V-0, COLOR: REFER TO CHART.

TERMINAL: BRASS

POST: BRASS

2. TERMINAL PLATING:

CONTACT AREA: (a) GOLD FLASH

(b) GOLD, THICKNESS=0.76 MICRON MINIMUM

(c) GOLD, THICKNESS=0.38 MICRON MINIMUM

SOLDER TAIL: TIN, THICKNESS=1.27 MICRON MINIMUM

UNDER PLATE: NICKEL PLATED, THICKNESS=1.27 MICRON MINIMUM

3. POST PLATING: UNDER PLATE: NICKEL, THICKNESS=1.25 MICRON MINIMUM

TIN, THICKNESS=1.9 MICRON MINIMUM OVER ALL

4. PACKAGING: PK-67800-001

5. PRODUCT SPECIFICATION REFER TO PS-67491-001

6. RECOMMENDED SOLDERING PROCESS: IR PROCESS

△ METAL POSTS TO BE SOLDERED TO PCB

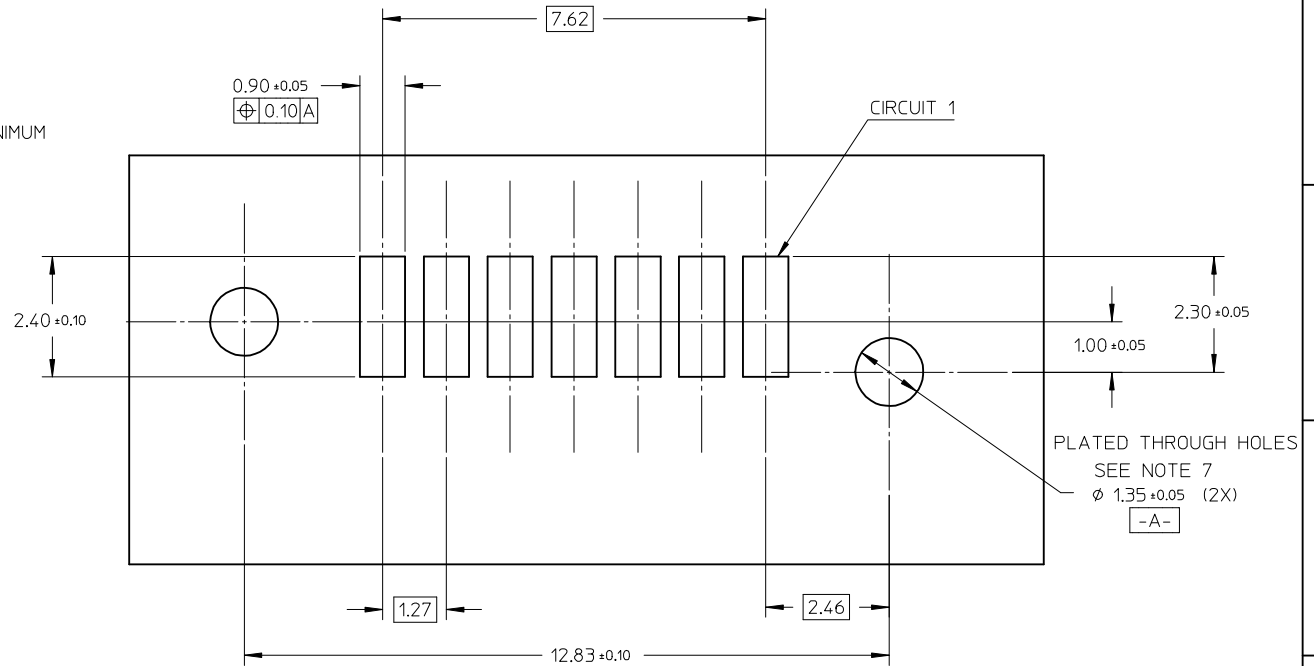

RECOMMENDED P.C.B LAYOUT
CONNECTOR SIDE

678005025	SEE NOTE2(c)	BLACK	3.45	PURE TIN
678005022	SEE NOTE2(b)			
678005021	SEE NOTE2(a)			
678005015	SEE NOTE2(c)	BLACK	3.05	
678005012	SEE NOTE2(b)			
678005011	SEE NOTE2(a)	BLACK	2.65	
678005005	SEE NOTE2(c)			
678005004	SEE NOTE2(c)			
678005003	SEE NOTE2(c)	BLUE	2.65	
678005002	SEE NOTE2(b)	BLACK		
678005001	SEE NOTE2(a)			
MATERIAL NO	PLATING TYPE	HOUSING COLOR	DIM A	REMARK

REVISED EC NO: SH2010-0043 2009/08/07 TIDRWINGLLI CHKD:XJSONG APPR:RZHANG 2009/08/10 2009/09/13	QUALITY SYMBOLS ▽=0 ◻=0	GENERAL TOLERANCES (UNLESS SPECIFIED)		DIMENSION STYLE MM ONLY		SCALE 5:1	DESIGN UNITS METRIC	THIRD ANGLE PROJECTION			
		4 PLACES ± --- ± ---	3 PLACES ± --- ± ---	mm	INCH	DRAWN BY GRATE MA	DATE 2004/02/02	TITLE HIGH SPEED CONNECTOR 1.27MM PITCH VERTICAL SMT SOLDER TAIL			
		2 PLACES ± 0.15 ± ---	1 PLACE ± 0.25 ± ---	ANGULAR ± 1 °		CHECKED BY YA JUN	DATE 2004/02/02	MOLEX INCORPORATED			
		DRAFT WHERE APPLICABLE MUST REMAIN WITHIN DIMENSIONS				APPROVED BY SAM	DATE 2004/02/02	MATERIAL NO. SEE CHART	DOCUMENT NO. SD-67800-005	SHEET NO. 2 OF 2	