

PART NUMBER: AMT303
DESCRIPTION: COMMUTATION ENCODER

The AMT 303 is a commutation encoder with additional incremental channels A, B, and Z. The encoder output utilizes standard U,V,W commutation signals with additional quadrature A,B and Index signals provided for speed control or positioning operations. A SPI serial bus allows for commutation settings to be easily adjusted via a demo board, or preconfigured and stored for large production assembly for various motor configurations.

FEATURES

- U,V,W Commutation lines
- Small Size 37mm
- Line count up to 1024
- Optional Line Driver output
- Single pulse index
- Capacitive ASIC technology
- Modular locking hub design for ease of installation
- 2,4,6,8,10,12, or 20 pole motors
- SPI adjustable settings
- 'One Touch' commutation signal alignment

ELECTRICAL SPECIFICATIONS

parameter	conditions/description	min	nom	max	units
power supply		4.5	5	5.5	V
current consumption			8	10	mA
commutation output signals	U, V, W phase				
commutation pole	2, 4, 6, 8, 10, 12, 20 (software programmable)				
incremental output signals	A, B, Z phase (\bar{A} , \bar{B} , \bar{Z} available on AMT303LD)				
incremental output waveform	square wave				
incremental output resolutions	96, 192, 200, 250, 400, 500, 512, 1024	96	512	1,024	ppr
Index	one pulse per 360 deg				
incremental output current	output voltage - sourcing to +5 V @ -32 mA output voltage - sinking to ground @ -32 mA	3.8		0.55	V V

MECHANICAL SPECIFICATIONS

parameter	conditions/description	min	nom	max	units
output range				360	deg
mounting hole options	A) 2 each M1.6 on 16 mm (0.63") bolt circle B) 2 each #4 on 19.05 mm (0.75") bolt circle C) 2 each M1.6 or M2 on 20 mm (0.787") bolt circle D) 3 each M1.6 or M2 on 20.9 mm (0.823") bolt circle with washers in option B holes E) 3 each M1.6 or M2 on 22 mm (0.866") bolt circle F) 4 each M1.6 or M2 on 25.4 mm (1") bolt circle				









ENVIRONMENTAL SPECIFICATIONS

parameter	conditions/description	min	nom	max	units
operating temperature		-40		125	°C
humidity				85	%RH
vibration	1.5mm, 3 directions, 2 hours	10		55	Hz

PART NUMBER: AMT303
DESCRIPTION: COMMUTATION ENCODER

AMT303-V KIT

In order to provide maximum flexibility for our customers, the AMT303 series is provided in kit form standard. This allows the user to implement the encoder into a range of applications using one sku#, reducing engineering and inventory costs.

SLEEVES								
								
8mm	1/4 inch (6.35mm)	6mm	5mm	3/16 inch (4.76mm)	4mm	1/8 inch (3.175mm)	3mm	2mm
Blue	Snow	Red1	Green1	Yellow1	Gray60	Purple1	Orange	Light Sky Blue

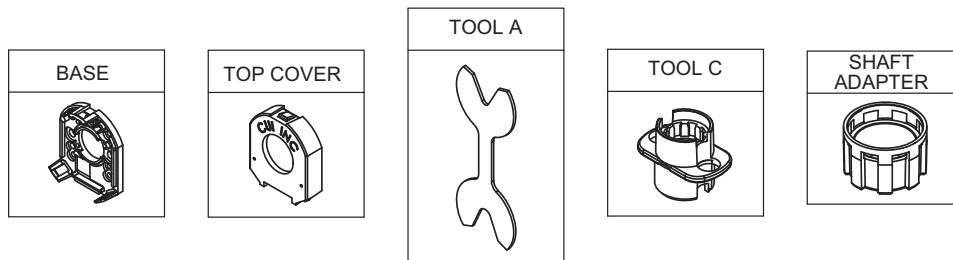

CUSTOM CONFIG KEY

For customers that prefer a specific AMT303 configuration, please reference the custom configuration key below.

AMT303 X - XXXX - XXXX

Output Signals:
 "blank" = A, B, Z
 LD = Line Driver
 A, B, Z
 A, B, Z

Resolution (ppr):
 0096
 0192
 0200
 0250
 0400
 0500
 0512
 0640
 1024

Sleeve Bore Diameter:
 2000 = 2 mm
 3000 = 3 mm
 3175 = 3.175 mm (1/8")
 4000 = 4 mm
 4760 = 4.76 mm (3/16")
 5000 = 5 mm
 6000 = 6 mm
 6350 = 6.35 mm (1/4")
 8000 = 8 mm

PART NUMBER: AMT303
DESCRIPTION: COMMUTATION ENCODER
ENCODER INTERFACE

PINOUT CONNECTOR 1		
FUNCTION		
#	AMT303	AMT303LD
14	GND_C	GND_C
13	N/A	-X
12	X	X
11	N/A	-A
10	A	A
9	N/A	-B
8	B	B
7	V	V
6	5 V+	5 V+
5	W	W
4	GND	GND
3	U	U
2	zero set	zero set
1	N/A	N/A

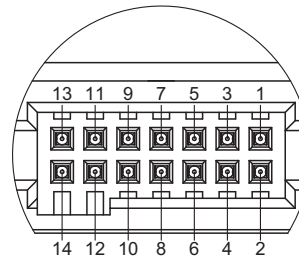
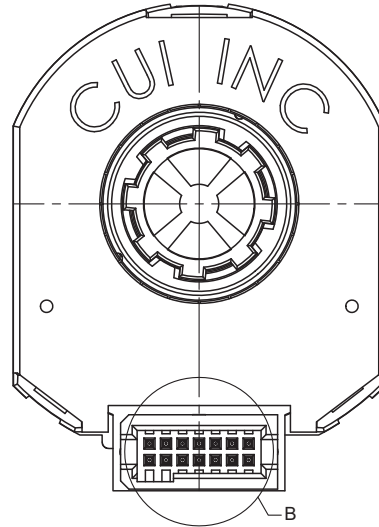
 DETAIL B
SCALE 4 : 1

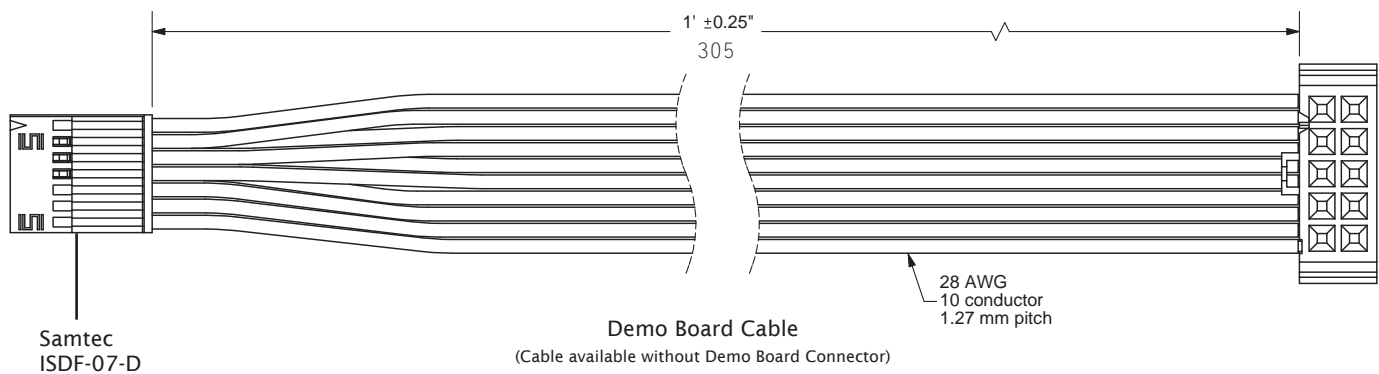
Encoder Side
Demo Board Side

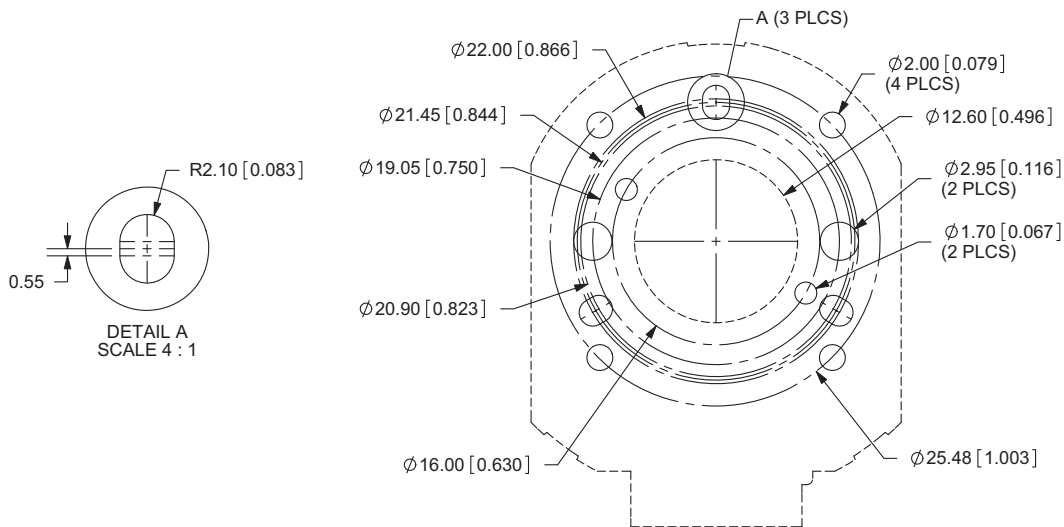
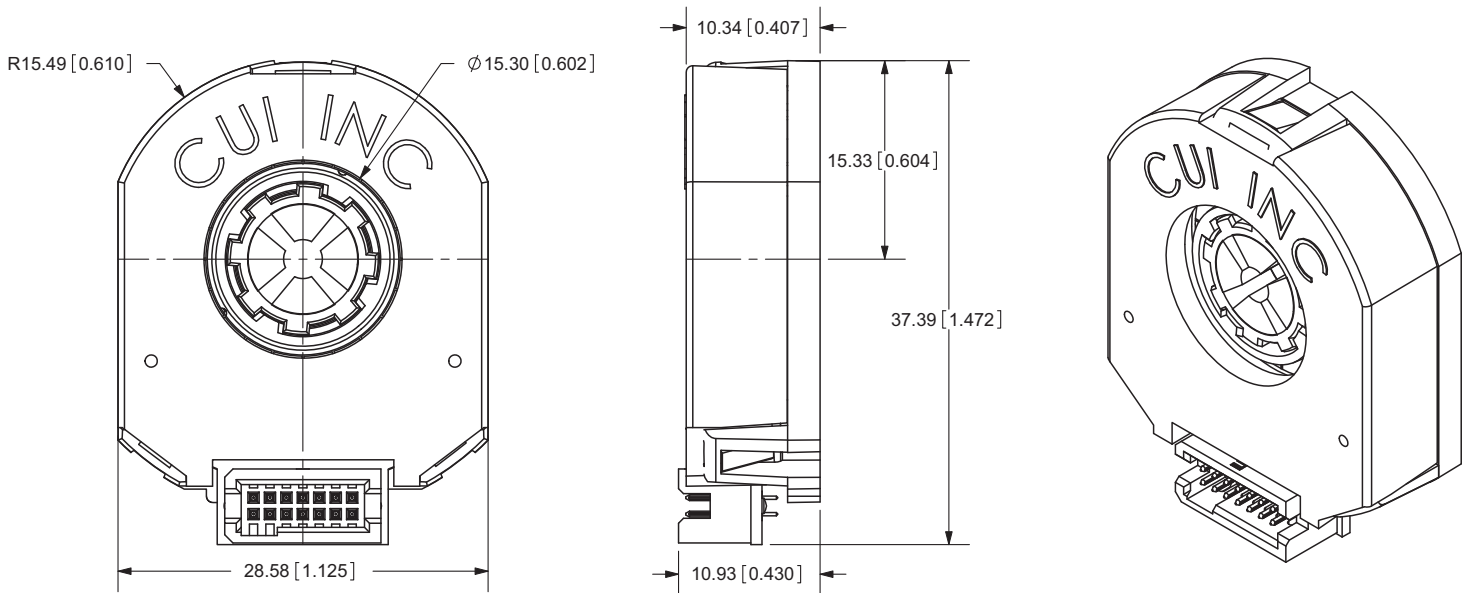
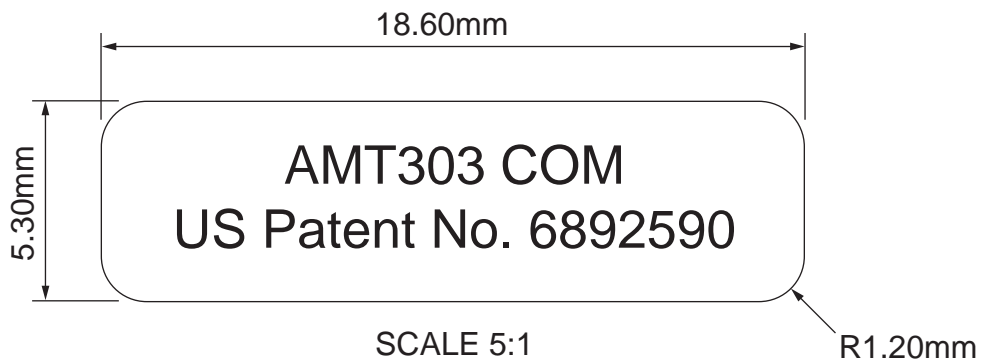
PART NUMBER: AMT303
DESCRIPTION: COMMUTATION ENCODER

 TOLERANCE:
 $\pm 0.05\text{mm}$ UNLESS OTHERWISE
 SPECIFIED

PART NUMBER: AMT303
DESCRIPTION: COMMUTATION ENCODER

APPLICATION NOTES

Encoder operational mode

- **Initialization mode:** At power up the encoder goes through an initiation and stabilization procedure. This includes microprocessor stabilization and the program for combining Coarse and Fine channel of the encoder for getting the absolute start position. This takes less than 0.1 seconds.
- **Tracking mode:**
 - MCU 12 bit position register is updated from Fine Asic every 48 μ s.
 - The commutation program in the MCU has a compensation for the average delay caused by the update rate, leaving a remaining jitter of less than 24 μ s RMS.
 - The communication jitter expressed in electrical degrees will be proportional speed and does not reach 6 deg RMS until the speed reaches the following values:

Pole Count	4	6	8	10	12	20
Speed Limit RPM	17,361	11,574	8,681	6,944	5,787	3,472

Serial Peripheral Interface Commands

The SPI or Serial Peripheral Interface Bus is a standard interface promoted by Motorola and Microchip among others. It consists of 4 signals:

- MOSI: Master Out Slave In
- MISO: Master In Slave Out
- SCK: Serial Clock
- CSB: Chip Select Bar (active low)

SPI BUS

The SPI bus runs full duplex and transfers multiples of 8 bits in a frame. The SPI type is the most common (CPOL=0, CPHA=0), also known as Microwire. Data is captured on the rising edge of SCK and the output data is changed after the falling edge of SCK.

Figure 7: SPI BUS Timing Diagram

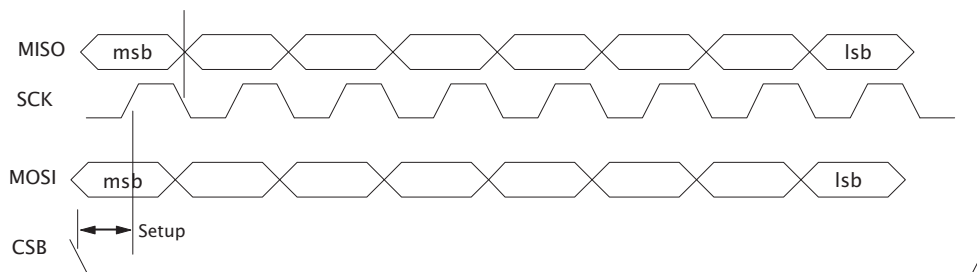

Terminology

MSB = most significant byte
 LSB = least significant byte
 msb = most significant bit
 lsb = least significant bit

Serial Peripheral Interface Bus (SPI) on AMT303

PART NUMBER: AMT303**DESCRIPTION: COMMUTATION ENCODER**

The msb data out on MISO is valid soon after CSB goes low. The MOSI data is valid soon after the falling edge of SCK. The Encoder drives data out on MISO as long as CSB is low.

Normally, CSB goes low, then after 8 clocks the command is interpreted. CSB high resets the clock counter, and terminates any command sequence.

SPI Commands:

The commands are all 8 bits long, the MSB is shifted in first, and is the leftmost bit shown in Figure 7.

Encoder Protocol Considerations:

The Encoder is designed to operate with a high speed SPI link, in full duplex mode. This implies the host can issue commands and read data as quickly as necessary but there has to be an acknowledgement from the slave just before the data is transferred.

Essentially the host issues a command, receives zero or more wait sequences (0xA5 or 1010,0101) then the echo of the command followed by an optional payload.

So, for example to read the position, the host issues rd_comm, receiving a series of wait sequences (0xA5) then a reflected rd_comm, then the MSB data followed by the LSB data.

It is recommended that the host leave a 20 μ s gap between reads to avoid extending the read time by forcing wait sequences.

Command 0x00: nop_a5

This command is ignored by the Encoder and simply causes the next data to be read. The encoder responds with 0xA5 if there is nothing else to send.

Note that it is possible to overlap commands, so instead of NOP is several steps above the user could start another operation. The read and write FIFOs for the PCI streams are 16 bytes long and it is up to the user to avoid overflow.

Command 0x51: rd_comm

This command causes the commutation values and EIDXN value to be read and put in the output fifo. The reply is 2 bytes, the first byte is reserved (eg. A lookup value between 0 and 31 but subject to change), the second byte has EIDXN,U,V,W in the low 4 bits.

PART NUMBER: AMT303**DESCRIPTION: COMMUTATION ENCODER****Command 0x70: set_zero_point**

This command sets the current position to zero or adjusts to the offset stored in comm_pos in the EEPROM and saves this setting in the EEPROM. The host should send nop_a5 repeatedly after sending this command, the response will be 0xa5 while update is proceeding and eeprom_wr is the response when update is finished. 0xF9 is the location for the Low Byte of comm_pos and 0xF8 is the location for the High Byte of comm_pos.

Comand 0x80,<byte_address>,<data>: eeprom_wr

This command causes the data to be written to the address given in <byte_address>. The address can be 0x00 to 0x7f for 128 bytes of data.

Comand 0x90,<byte_address>,0x01: eeprom_rd

This command causes the data in eeprom at the given address to be read and put in the output fifo. The sequence is as follows:

- 1) issue read command, receive idle character
- 2) issue NOP, receive idle character or 0x90 (echo of read command)
- 3) repeat step 2 if it is an idle character
- 4) issue NOP and receive

Commutation Alignment and setting the Zero point

To align the commutation angle with the encoder there are two steps:

- 1) Configure the encoder alignment angle using the Demo Board. The alignment angle is the angle relative to U,V,W poles which is used for setting the encoder on the armature. The alignment angle is set at the same time as several other parameters, and the encoder must be power cycled after configuration.
- 2) With the encoder mounted, position the rotor to the alignment angle and use the "zero" command on the demo board to write the rotor position in non-volatile memory in the encoder. The encoder must be power cycled after this operation, and it will use this offset at initialization every time at startup.

Note: the demo board allows setting the alignment angle between -180 and 180 degrees in increments of 5 degrees. 0 (zero) degrees corresponds to the rising edge of the U signal. The direction of rotation can also be set.