

**PLEASE CHECK WWW.MOLEX.COM FOR LATEST PART INFORMATION**

**Part Number:** [0330113003](#)  
**Status:** **Active**  
**Overview:** [mx150 sealed connector system](#)  
**Description:** MX150™ Male Terminal, Silver (Ag) Plating, 14 AWG, Left Reel Payoff, Contact Material Thickness 0.30mm (.012")

**Documents:**

[Drawing \(PDF\)](#) [RoHS Certificate of Compliance \(PDF\)](#)

**General**

Product Family	Crimp Terminals
Series	<a href="#">33011</a>
Comments	Left Reel Payoff
Crimp Quality Equipment	Yes
Overview	<a href="#">mx150 sealed connector system</a>
Product Name	MX150™

**Physical**

Gender	Male
Material - Metal	High Performance Alloy (HPA)
Material - Plating Mating	Silver
Material - Plating Termination	Tin
Packaging Type	Reel
Plating min: Mating (µin)	30.4
Plating min: Mating (µm)	0.76
Plating min: Termination (µin)	100
Plating min: Termination (µm)	2.5
Termination Interface: Style	Crimp or Compression
Wire Insulation Diameter	2.60mm (.102") max.
Wire Size AWG	14
Wire Size mm²	1.5

**Electrical**

Current - Maximum per Contact	22A
Voltage - Maximum	250V

**Material Info**

**Reference - Drawing Numbers**

Sales Drawing	SD-33000-001
---------------	--------------



Series

*image - Reference only*

**EU RoHS**

**ELV and RoHS  
Compliant**

**REACH SVHC**

Not Reviewed

**Halogen-Free**

**Status**

**Not Reviewed**

**China RoHS**



**Need more information on product  
environmental compliance?**

Email [productcompliance@molex.com](mailto:productcompliance@molex.com)  
 For a multiple part number RoHS Certificate of Compliance, [click here](#)

Please visit the [Contact Us](#) section for any non-product compliance questions.

**Search Parts in this Series**

[33011Series](#)

**Use With**

[33482](#) Dual Row Housing, [33481](#) Single Row Housing, [33486](#) Hybrid Housing

**Application Tooling | FAQ**

*Tooling specifications and manuals are found by selecting the products below. Crimp Height Specifications are then contained in the Application Tooling Specification document.*

**Global**

Description	Product #
FineAdjust™ Applicator	<a href="#">0639000200</a>
Hand Crimp Tool, 14-16AWG	<a href="#">0638112400</a>

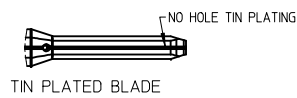
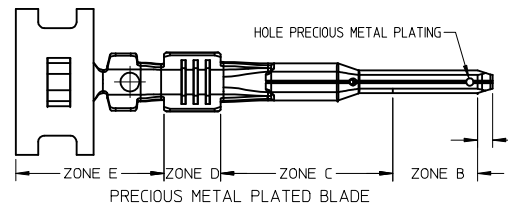
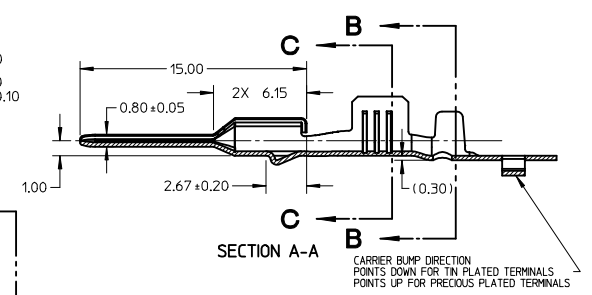
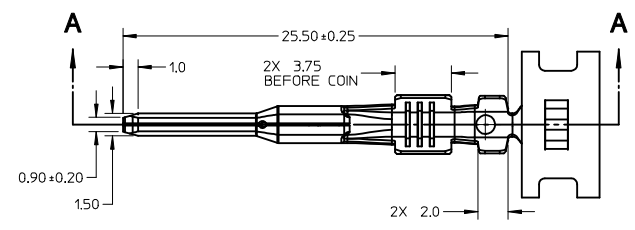
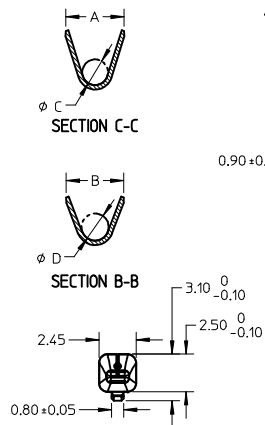
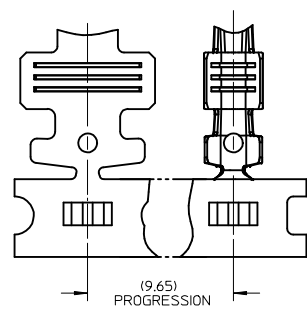
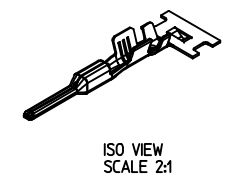
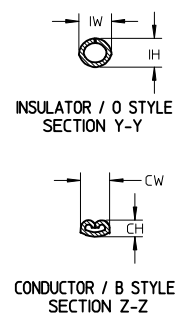
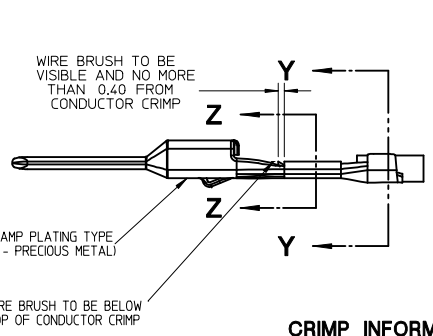

- PLATING NOTES:
- PRECIOUS METAL PLATED TERMINAL:
    - GOLD PLATING:
      - ZONE A: SHALL BE COMPLETELY COVERED WITH NICKEL TO PREVENT EXPOSED BASE METAL REDUCED GOLD THICKNESS FROM ZONE B PERMITTED
      - ZONE B: PRECIOUS METAL PLATING PER MOLEX PLATING SPECIFICATION ES-88
        - BASE LAYER: ELECTRODEPOSITED DUCTILE SULFAMATE NICKEL THICKNESS: 1.25 - 2.25 MICROMETERS
        - GOLD LAYER: ELECTRODEPOSITED GOLD THICKNESS: 0.76 MICROMETERS MINIMUM
      - ZONE C: SHALL BE COMPLETELY COVERED WITH NICKEL TO PREVENT EXPOSED BASE METAL REDUCED PLATING THICKNESS FROM ZONE B AND ZONE D PERMITTED
      - ZONE D: TIN PLATING PER MOLEX PLATING SPECIFICATION ES-88
        - BASE LAYER: ELECTRODEPOSITED DUCTILE SULFAMATE NICKEL THICKNESS: 1.25 - 2.25 MICROMETERS
        - TIN LAYER: ELECTRODEPOSITED 100% TIN, MATTE FINISH THICKNESS: 2.5 - 4.0 MICROMETERS
      - ZONE E: SHALL BE COMPLETELY COVERED WITH NICKEL TO PREVENT EXPOSED BASE METAL REDUCED THICKNESS FROM ZONE D PERMITTED
    - SILVER PLATING:
      - ZONE A: SHALL BE COMPLETELY COVERED WITH NICKEL TO PREVENT EXPOSED BASE METAL REDUCED SILVER THICKNESS FROM ZONE B PERMITTED
      - ZONE B: SILVER PLATING
        - BASE LAYER: ELECTRODEPOSITED DUCTILE SULFAMATE NICKEL THICKNESS: 1.25 - 2.25 MICROMETERS
        - SILVER LAYER: ELECTRODEPOSITED PURE SILVER (0.5% MAX IMPURITIES) THICKNESS: 1.9 - 3.3 MICROMETERS FINISH: SEMI BRIGHT
      - ANTI-TARNISH: TREATMENT FOR SILVER PLATED TERMINAL - EVABRITE WS
      - ZONE C: SHALL BE COMPLETELY COVERED WITH NICKEL TO PREVENT EXPOSED BASE METAL REDUCED PLATING THICKNESS FROM ZONE B AND ZONE D PERMITTED
      - ZONE D: TIN PLATING PER MOLEX PLATING SPECIFICATION ES-88
        - BASE LAYER: ELECTRODEPOSITED DUCTILE SULFAMATE NICKEL THICKNESS 1.25 - 2.25 MICROMETERS
        - TIN LAYER: ELECTRODEPOSITED 100% TIN, MATTE FINISH THICKNESS 2.5 - 4.0 MICROMETERS
      - ZONE E: SHALL BE COMPLETELY COVERED WITH NICKEL TO PREVENT EXPOSED BASE METAL REDUCED THICKNESS FROM ZONE D PERMITTED
  - TIN PLATED TERMINAL (ENTIRE TERMINAL)
    - BASE LAYER: ELECTRODEPOSITED ADVANCED TIN BARRIER THICKNESS 0.25 - 1.00 MICROMETERS
    - TIN LAYER: ELECTRODEPOSITED REFLOW TIN, 100% TIN, NO BRIGHTENERS THICKNESS 0.50 - 1.00 MICROMETERS

- GENERAL NOTES: (UNLESS OTHERWISE SPECIFIED)
- MATING TERMINAL SHOWN ON SD-33012-002
  - MATERIAL: ASTM B422, UNS C19025, HR04 THICKNESS: 0.30 mm ±0.01 TEMPER: FULL HARD (REF) TENSILE: 496-572 MPA PLATING: SEE PLATING NOTES
  - MEETS CRIMP PERFORMANCE SPECIFICATION SAE/USCAR-21 (RELEASED: 08/25/01)
  - MEETS PERFORMANCE STANDARD FOR AUTOMOTIVE ELECTRICAL CONNECTOR SYSTEMS SAE/USCAR-2 REV 3 (APRIL 2001)
  - MEETS FIELD CORRELATED LIFE TEST SAE/USCAR-20 (NOVEMBER 2001)
  - MEETS WIRING COMPONENT DESIGN GUIDELINES SAE/USCAR-12 REV 2 (DECEMBER 2001)
  - MEETS ELECTRICAL CONNECTION SYSTEM DESIGN SPECIFICATION (SDS) REV 11 (5/2002)
  - REFERENCE PK-31300-516 FOR REEL DIRECTION
  - REFERENCE CS-33000-001 FOR ADDITIONAL CRIMP INFORMATION

ENTER DESCRIPTION EC NO: UAU2010-0107 DRINKFERGUSON 2009/08/18 CHKD:A.DHIR 2009/08/19 APPR:BMOSER 2009/08/20 REV C10	QUALITY SYMBOLS ▽=0 ▽=0	GENERAL TOLERANCES (UNLESS SPECIFIED)		DIMENSION STYLE MM ONLY		SCALE 4:1	DESIGN UNITS METRIC	THIRD ANGLE PROJECTION																	
		<table border="1"> <tr> <th></th> <th>mm</th> <th>INCH</th> </tr> <tr> <td>4 PLACES</td> <td>± ---</td> <td>± ---</td> </tr> <tr> <td>3 PLACES</td> <td>± ---</td> <td>± ---</td> </tr> <tr> <td>2 PLACES</td> <td>± 0.1</td> <td>± ---</td> </tr> <tr> <td>1 PLACE</td> <td>± 0.3</td> <td>± ---</td> </tr> </table>			mm	INCH	4 PLACES	± ---	± ---	3 PLACES	± ---	± ---	2 PLACES	± 0.1	± ---	1 PLACE	± 0.3	± ---	DRAWN BY DATE L.PULLIAM 2006/01/31		TITLE MX150 15MM BLADE TERMINAL		MOLEX INCORPORATED		SHEET NO. 1 OF 5
			mm	INCH																					
		4 PLACES	± ---	± ---																					
3 PLACES	± ---	± ---																							
2 PLACES	± 0.1	± ---																							
1 PLACE	± 0.3	± ---																							
ANGULAR ± 3 °		CHECKED BY DATE A.DHIR 2006/02/01		APPROVED BY DATE B.MOSER 2006/02/02																					
				MATERIAL NO. SEE TABLE		DOCUMENT NO. SD-33000-001																			
THIS DRAWING CONTAINS INFORMATION THAT IS PROPRIETARY TO MOLEX INCORPORATED AND SHOULD NOT BE USED WITHOUT WRITTEN PERMISSION																									

TABLE 2 - TERMINAL GRIP/CRIMP TOOL DIM. REFERENCE TABLE																						
SUPPLIER PART NO. B DIRECTION RIGHT PAYOFF	D DIRECTION LEFT PAYOFF	FORD PART NO.	PLATING (STAMPING)	WIRE APPLICATION			A +0.30	B +0.30	C +0.30	D +0.30	E +0.005	F +0.005	G +0.005	J +0.005	K +0.005	M +0.005	N +0.005	P +0.005	R +0.005	U +0.005	V +0.005	
				WIRE SPECIFICATION	METRIC (mm)	WIRE SPECIFICATION																
33000-0001	33000-1001	ZL1T-14421-DA	TIN	14	MIL-123A/MIL-135A1	2.0, 1.5	MIL-126A1 JASO D 611	3.9	3.8	1.7	1.6	12.82	0.60	1.19	7.05	13.12	1.35	6.91	2.44	6.11	2.72	1.40
				16	MIL-123A	-		3.3	3.1	1.3	1.4	12.46	0.57	0.99	6.52	12.96	1.28	6.51	2.14	1.93	2.52	1.30
33000-0002	33000-1002	ZL1T-14421-CA	TIN	18	MIL-123A	10, 0.75	MIL-126A1	3.3	3.1	1.3	1.4	12.46	0.57	0.99	6.52	12.65	1.13	6.46	2.14	1.93	2.23	1.15
				20	SAE J1128 (IGXL)	-		3.3	3.1	1.3	1.4	12.46	0.57	0.99	6.52	12.96	1.28	6.51	2.14	1.93	2.52	1.30
				18	MIL-123A	-		3.3	3.1	1.3	1.4	12.46	0.57	0.99	6.52	12.42	1.03	6.36	2.14	1.93	2.04	1.05
33000-0003	33000-1003	ZL1T-14421-BA	TIN	22	MIL-123A	0.5	MIL-126A1 JASO D 611	2.5	2.6	0.9	1.0	11.97	0.42	0.72	6.57	12.24	0.93	6.31	1.60	1.44	1.84	0.95
33000-0003*	33000-1003*	ZL1T-14421-BA*	TIN	-	-	0.35	WSK-1A348-A2	2.5	2.6	0.9	1.0	11.97	0.42	0.72	6.57	12.24	0.93	6.31	1.60	1.44	1.84	0.95
33000-0024*	33000-1024*	4L2T-14421-AA*	TIN	-	-	0.35 + 0.35	MIL-126A1	T80	T80	T80	T80	T80	T80	T80	T80	T80	T80	T80	T80	T80	T80	T80
33000-0024*	33000-1024*	4L2T-14421-AA*	TIN	-	-	0.35 + 0.50	MIL-126A1	T80	T80	T80	T80	T80	T80	T80	T80	T80	T80	T80	T80	T80	T80	T80
33011-1002	33011-0002	ZL1T-14421-GA	GOLD	14	MIL-123A/MIL-135A1	2.0, 1.5	MIL-126A1 JASO D 611	3.9	3.8	1.7	1.6	12.82	0.60	1.19	7.05	13.12	1.35	6.91	2.44	6.11	2.72	1.40
				16	MIL-123A	-		3.3	3.1	1.3	1.4	12.46	0.57	0.99	6.52	12.96	1.28	6.51	2.14	1.93	2.52	1.30
33011-1004	33011-0004	ZL1T-14421-FA	GOLD	18	MIL-123A	10, 0.75	MIL-126A1	3.3	3.1	1.3	1.4	12.46	0.57	0.99	6.52	12.65	1.13	6.46	2.14	1.93	2.23	1.15
				20	SAE J1128 (IGXL)	-		3.3	3.1	1.3	1.4	12.46	0.57	0.99	6.52	12.96	1.28	6.51	2.14	1.93	2.52	1.30
				18	MIL-123A	-		3.3	3.1	1.3	1.4	12.46	0.57	0.99	6.52	12.42	1.03	6.36	2.14	1.93	2.04	1.05
33011-1006	33011-0006	ZL1T-14421-EA	GOLD	22	MIL-123A	0.5	MIL-126A1 JASO D 611	2.5	2.6	0.9	1.0	11.97	0.42	0.72	6.57	12.24	0.93	6.31	1.60	1.44	1.84	0.95
33011-1006*	33011-0006*	ZL1T-14421-EA*	GOLD	-	-	0.35	WSK-1A348-A2	2.5	2.6	0.9	1.0	11.97	0.42	0.72	6.57	12.24	0.93	6.31	1.60	1.44	1.84	0.95
33011-2003	33011-3003	7U5T-14421-CA	SILVER	14	MIL-123A/MIL-135A1	2.0, 1.5	MIL-126A1 JASO D 611	3.9	3.8	1.7	1.6	12.82	0.60	1.19	7.05	13.12	1.35	6.91	2.44	6.11	2.72	1.40
33011-2002	33011-3002	7U5T-14421-BA	SILVER	16	MIL-123A	-		3.3	3.1	1.3	1.4	12.46	0.57	0.99	6.52	12.96	1.28	6.51	2.14	1.93	2.52	1.30
				18	MIL-123A	10, 0.75	MIL-126A1	3.3	3.1	1.3	1.4	12.46	0.57	0.99	6.52	12.65	1.13	6.46	2.14	1.93	2.23	1.15
				20	SAE J1128 (IGXL)	-		3.3	3.1	1.3	1.4	12.46	0.57	0.99	6.52	12.96	1.28	6.51	2.14	1.93	2.52	1.30
33011-2001	33011-3001	7U5T-14421-AA	SILVER	22	MIL-123A	0.5	MIL-126A1 JASO D 611	2.5	2.6	0.9	1.0	11.97	0.42	0.72	6.57	12.24	0.93	6.31	1.60	1.44	1.84	0.95
33011-2001*	33011-3001*	7U5T-14421-AA*	SILVER	-	-	0.35	WSK-1A348-A2	2.5	2.6	0.9	1.0	11.97	0.42	0.72	6.57	12.24	0.93	6.31	1.60	1.44	1.84	0.95

\* UNSEALED APPLICATIONS ONLY

TABLE 1 - TERMINAL CRIMP DIMENSIONS REFERENCE TABLE											
SUPPLIER PART NO. B DIRECTION RIGHT PAYOFF	D DIRECTION LEFT PAYOFF	FORD PART NO.	PLATING	WIRE SIZE	WIRE SPECIFICATION	CONDUCTOR CH (SECT Z-Z) +0.05 mm	CONDUCTOR CW (SECT Z-Z) +0.10 mm	INSULATOR IH (SECT Y-Y) +0.10 mm	INSULATOR IW (SECT Y-Y) +0.10 mm	WIRE PULL FORCE (N)	
33000-0001	33000-1001	ZL1T-14421-DA	TIN	14 awg	MIL-123A	1.65	2.45	2.85	2.75	339	
				16 awg	MIL-135A1	1.65	2.45	2.80	2.80	339	
33000-0002	33000-1002	ZL1T-14421-CA	TIN	18 awg	MIL-123A	1.25	2.15	2.00	2.30	157	
				20 awg	SAE J1128 (IGXL)	1.25	2.15	2.30	2.60	158	
				18 awg	MIL-123A	1.15	2.15	1.90	2.10	113	
33000-0003	33000-1003	ZL1T-14421-BA	TIN	22 awg	MIL-123A	1.00	1.60	1.85	1.90	62	
33000-0001	33000-1001	ZL1T-14421-DA	TIN	2.0 mm <sup>2</sup>	JASO D 611 (AVSSI)	1.60	2.45	2.85	2.75	233	
33000-0002	33000-1002	ZL1T-14421-CA	TIN	1.5 mm <sup>2</sup>	MIL-126A1	1.40	2.25	2.65	2.80	177	
				1.0 mm <sup>2</sup>	MIL-126A1	1.30	2.15	2.00	2.30	162	
				0.75 mm <sup>2</sup>	MIL-126A1	1.25	2.15	1.95	2.30	145	
33000-0003	33000-1003	ZL1T-14421-BA	TIN	0.5 mm <sup>2</sup>	MIL-126A1	1.10	1.60	1.80	1.90	82	
33000-0003*	33000-1003*	ZL1T-14421-BA*	TIN	0.35 mm <sup>2</sup>	JASO D 611 (AVSSI)	1.10	1.60	1.85	1.90	100	
33000-0024*	33000-1024*	4L2T-14421-AA*	TIN	0.35 + 0.35	WSK-1A348-A2	0.95	1.60	1.70	1.90	50	
33000-0024*	33000-1024*	4L2T-14421-AA*	TIN	0.35 + 0.50	MIL-126A1	T80	T80	T80	T80	T80	
33011-1002	33011-0002	ZL1T-14421-GA	GOLD	14 awg	MIL-123A	1.65	2.45	2.85	2.75	339	
				16 awg	MIL-135A1	1.65	2.45	2.80	2.80	339	
33011-1004	33011-0004	ZL1T-14421-FA	GOLD	18 awg	MIL-123A	1.25	2.15	2.00	2.30	157	
				20 awg	SAE J1128 (IGXL)	1.25	2.15	2.30	2.60	158	
				18 awg	MIL-123A	1.15	2.15	1.90	2.10	113	
33011-1006	33011-0006	ZL1T-14421-EA	GOLD	22 awg	MIL-123A	1.00	1.60	1.85	1.90	62	
33011-1002	33011-0002	ZL1T-14421-GA	GOLD	2.0 mm <sup>2</sup>	JASO D 611 (AVSSI)	1.60	2.45	2.85	2.75	233	
33011-1004	33011-0004	ZL1T-14421-FA	GOLD	1.5 mm <sup>2</sup>	MIL-126A1	1.40	2.25	2.65	2.80	177	
				1.0 mm <sup>2</sup>	MIL-126A1	1.30	2.15	2.00	2.30	162	
				0.75 mm <sup>2</sup>	MIL-126A1	1.25	2.15	1.95	2.30	145	
33011-1006	33011-0006	ZL1T-14421-EA	GOLD	0.5 mm <sup>2</sup>	MIL-126A1	1.10	1.60	1.80	1.90	82	
33011-1006*	33011-0006*	ZL1T-14421-EA*	GOLD	0.35 mm <sup>2</sup>	JASO D 611 (AVSSI)	1.10	1.60	1.85	1.90	100	
33011-2003	33011-3003	7U5T-14421-CA	SILVER	14 awg	MIL-123A	1.65	2.45	2.85	2.75	339	
33011-2002	33011-3002	7U5T-14421-BA	SILVER	16 awg	MIL-135A1	1.65	2.45	2.80	2.80	339	
				18 awg	MIL-123A	1.25	2.15	2.00	2.30	157	
				20 awg	SAE J1128 (IGXL)	1.25	2.15	2.30	2.60	158	
33011-2001	33011-3001	7U5T-14421-AA	SILVER	22 awg	MIL-123A	1.00	1.60	1.85	1.90	62	
33011-2003	33011-3003	7U5T-14421-CA	SILVER	2.0 mm <sup>2</sup>	JASO D 611 (AVSSI)	1.60	2.45	2.85	2.75	233	
33011-2002	33011-3002	7U5T-14421-BA	SILVER	1.5 mm <sup>2</sup>	MIL-126A1	1.40	2.25	2.65	2.80	177	
				1.0 mm <sup>2</sup>	MIL-126A1	1.30	2.15	2.00	2.30	162	
				0.75 mm <sup>2</sup>	MIL-126A1	1.25	2.15	1.95	2.30	145	
33011-2001	33011-3001	7U5T-14421-AA	SILVER	0.5 mm <sup>2</sup>	MIL-126A1	1.10	1.60	1.80	1.90	82	
33011-2001*	33011-3001*	7U5T-14421-AA*	SILVER	0.35 mm <sup>2</sup>	JASO D 611 (AVSSI)	1.10	1.60	1.85	1.90	100	
33011-2001*	33011-3001*	7U5T-14421-AA*	SILVER	0.35 mm <sup>2</sup>	WSK-1A348-A2	0.95	1.60	1.70	1.90	50	

\* UNSEALED APPLICATIONS ONLY

ENTER DESCRIPTION  
EC NO: UAU2010-0107  
DRANKFERGUSON 2009/08/18  
CHKD-A:DHIR 2009/08/19  
APPR:BMOSER 2009/08/20  
REV

QUALITY  
SYMBOLS  
▽=0  
▽=0

GENERAL TOLERANCES  
(UNLESS SPECIFIED)

	mm	INCH
4 PLACES ±	---	± ---
3 PLACES ±	---	± ---
2 PLACES ±	0.1	± ---
1 PLACE ±	0.3	± ---

ANGULAR ± 3 °

DRAFT WHERE APPLICABLE  
MUST REMAIN  
WITHIN DIMENSIONS

DIMENSION STYLE  
MM ONLY

DRAWN BY DATE  
L.PULLIAM 2006/01/31

CHECKED BY DATE  
A.DHIR 2006/02/01

APPROVED BY DATE  
B.MOSER 2006/02/02

MATERIAL NO.  
9999999999

SCALE  
1:1

DESIGN UNITS  
METRIC

THIRD ANGLE  
PROJECTION

TITLE  
MX150 15MM BLADE  
TERMINAL

MOLEX MOLEX INCORPORATED

DOCUMENT NO.  
SD-33000-001

SHEET NO.  
2 OF 5

THIS DRAWING CONTAINS INFORMATION THAT IS PROPRIETARY TO MOLEX  
INCORPORATED AND SHOULD NOT BE USED WITHOUT WRITTEN PERMISSION

### CRIMP TOOL INFORMATION EXCEPT 14 GA

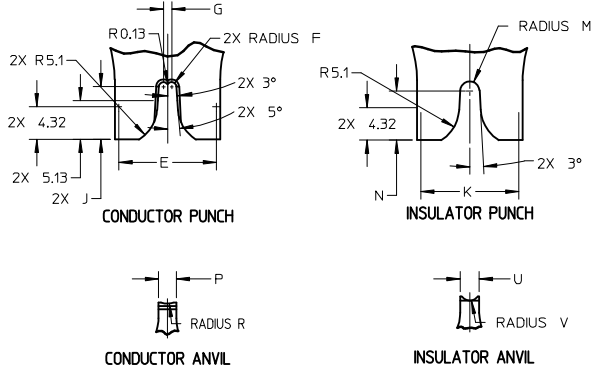

### 14 GA CRIMP TOOLING

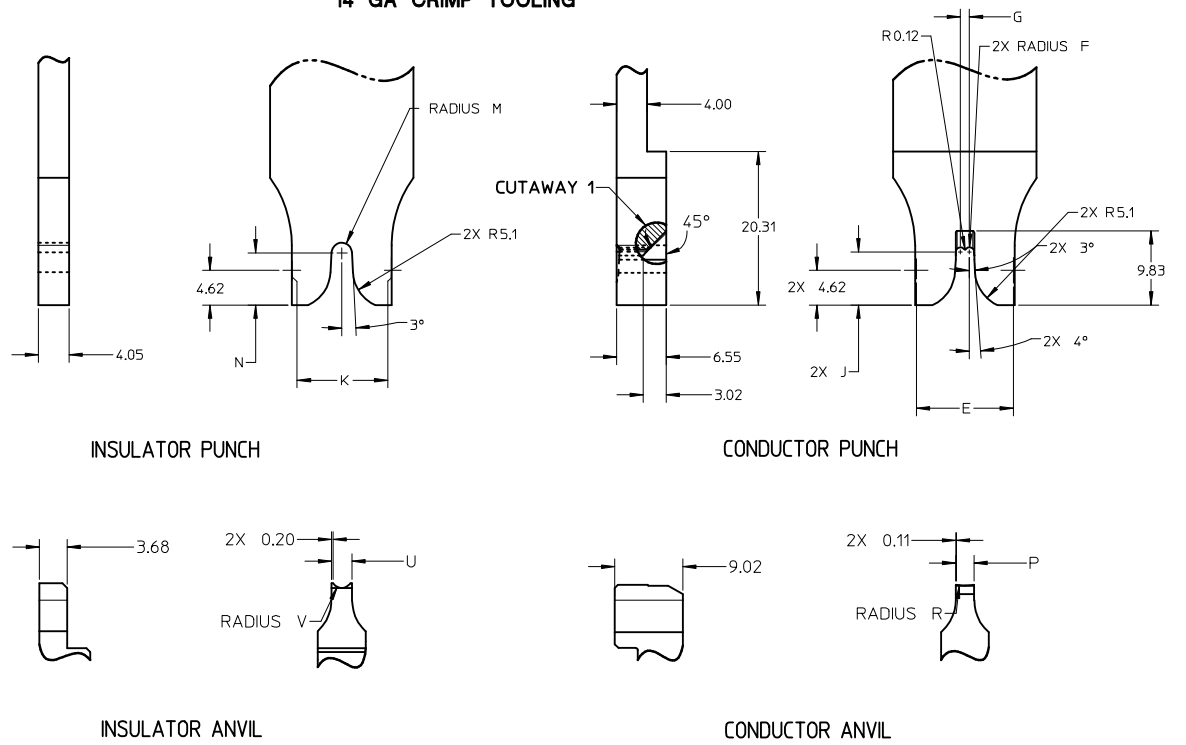

<b>ENTER DESCRIPTION</b> EC NO: UAU2010-0107 DRWNG: FERGIJUN 2009/08/18 CHKD: A.DHIR 2009/08/19 APPR: B.MOSER 2009/08/20 REV: C10	QUALITY SYMBOLS ▼=0 ▽=0	GENERAL TOLERANCES (UNLESS SPECIFIED) <table border="1"> <tr> <th></th> <th>mm</th> <th>INCH</th> </tr> <tr> <td>4 PLACES</td> <td>± .005</td> <td>± .0004</td> </tr> <tr> <td>3 PLACES</td> <td>± .008</td> <td>± .0003</td> </tr> <tr> <td>2 PLACES</td> <td>± 0.1</td> <td>± .004</td> </tr> <tr> <td>1 PLACE</td> <td>± 0.3</td> <td>± .012</td> </tr> </table>		mm	INCH	4 PLACES	± .005	± .0004	3 PLACES	± .008	± .0003	2 PLACES	± 0.1	± .004	1 PLACE	± 0.3	± .012	DIMENSION STYLE <b>MM ONLY</b> DRAWN BY DATE L.PULLIAM 2006/01/31 CHECKED BY DATE A.DHIR 2006/02/01 APPROVED BY DATE B.MOSER 2006/02/02	SCALE <b>2:1</b> DESIGN UNITS <b>METRIC</b> THIRD ANGLE PROJECTION	TITLE <b>MX150 15MM BLADE TERMINAL</b>
		mm	INCH																	
	4 PLACES	± .005	± .0004																	
	3 PLACES	± .008	± .0003																	
2 PLACES	± 0.1	± .004																		
1 PLACE	± 0.3	± .012																		
MATERIAL NO. <b>SEE TABLE</b>		DOCUMENT NO. <b>SD-33000-001</b>		SHEET NO. <b>3 OF 5</b>																
THIS DRAWING CONTAINS INFORMATION THAT IS PROPRIETARY TO MOLEX INCORPORATED AND SHOULD NOT BE USED WITHOUT WRITTEN PERMISSION																				

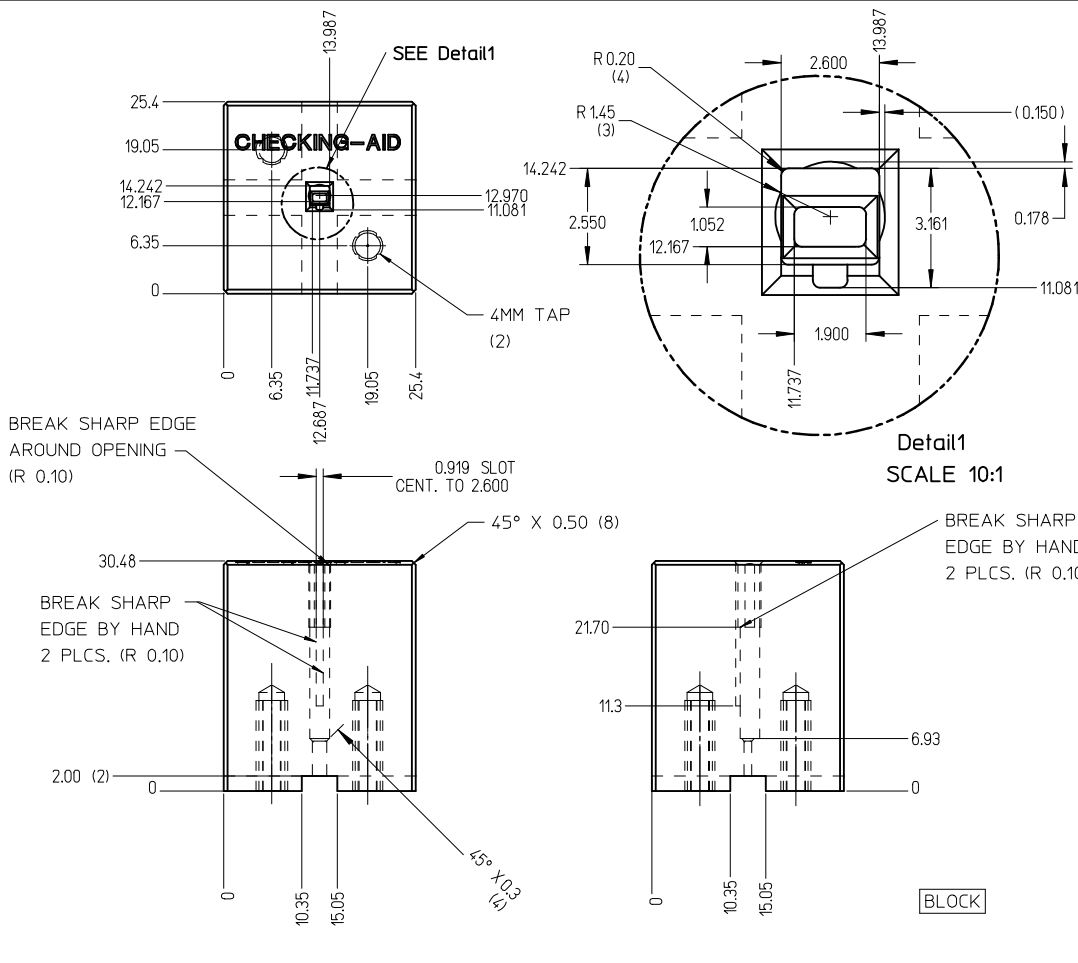

CHECKING-AID  
 2 PIECE ASM. A2 TOOL STEEL  
 HARDEN & GRIND TO A ROCKWELL  
 HARDNESS "C" SCALE OF 56-58

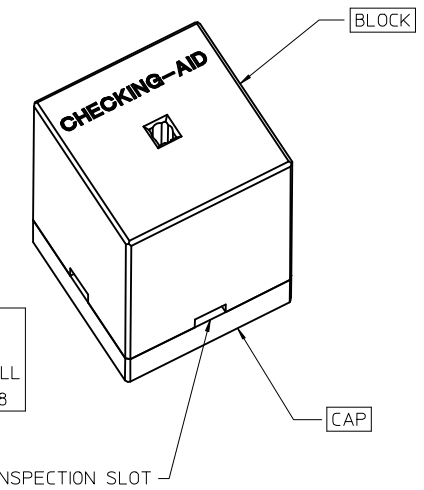

CHECKING AID TOLERANCE	
.XXX	= .005
.XX	= .03
.X	= .3

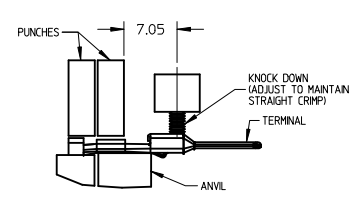
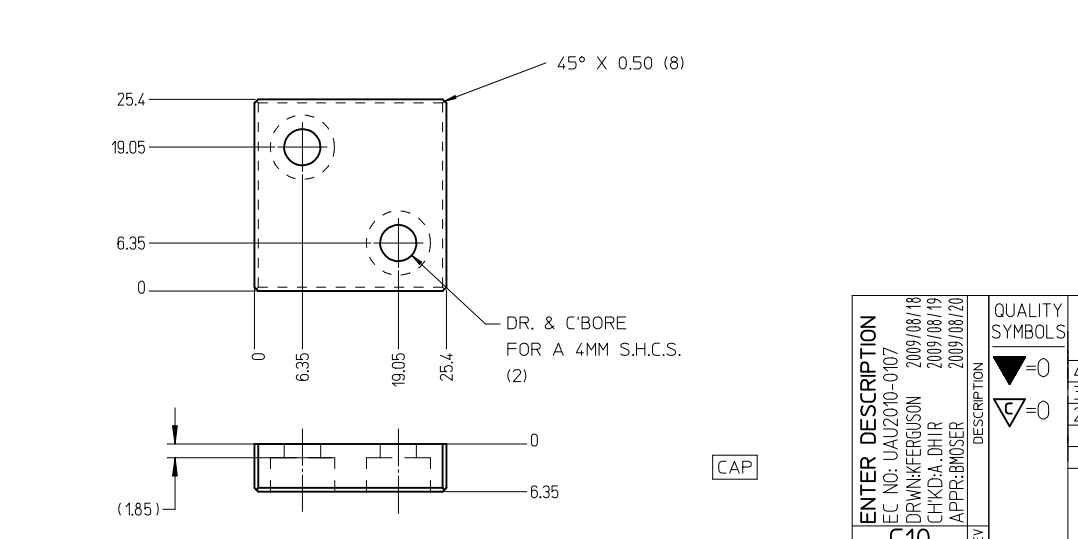

- CRIMP REQUIREMENTS:
1. CRIMP STRAIGHTNESS MUST BE MAINTAINED. USE A KNOCKDOWN TOOL LOCATED AS SHOWN. TERMINAL BOX MUST NOT BE DEFORMED
  2. AFTER CRIMPING, THE TERMINAL AND WIRE MUST FIT FREELY INTO THE CHECKING AID 33000-700. PROPER INSERTION DEPTH IS MET WHEN BLADE TIP STOPS ON CAP. SLOTS PROVIDED TO VISUALLY INSPECT STOPPAGE OF PIN TIP.
  3. FOR OTHER MECHANICAL REQUIREMENTS ON CRIMPED TERMINALS, REFER TO SAE/USCAR-21 (5-13-02) SECTIONS 4.2 (VISUAL INSPECTION), 4.3 (CROSS SECTION ANALYSIS) AND 4.4 (CONDUCTOR CRIMP PULLOUT FORCE)

<b>ENTER DESCRIPTION</b> EC NO: UAU2010-0107 DRWNKFERGUSON 2009/08/18 CHKD:A.DHIR 2009/08/19 APPR:BMOSER 2009/08/20 REV:	<b>QUALITY SYMBOLS</b> ▽=0 ▽=0	<b>GENERAL TOLERANCES (UNLESS SPECIFIED)</b> <table border="1"> <tr><th></th><th>mm</th><th>INCH</th></tr> <tr><td>4 PLACES</td><td>± .005</td><td>± .0001</td></tr> <tr><td>3 PLACES</td><td>± .005</td><td>± .0001</td></tr> <tr><td>2 PLACES</td><td>± 0.1</td><td>± .004</td></tr> <tr><td>1 PLACE</td><td>± 0.3</td><td>± .012</td></tr> </table>		mm	INCH	4 PLACES	± .005	± .0001	3 PLACES	± .005	± .0001	2 PLACES	± 0.1	± .004	1 PLACE	± 0.3	± .012	<b>DIMENSION STYLE</b> <b>MM ONLY</b>	<b>SCALE</b> <b>2:1</b>	<b>DESIGN UNITS</b> <b>METRIC</b>	<b>THIRD ANGLE PROJECTION</b>
		mm	INCH																		
	4 PLACES	± .005	± .0001																		
	3 PLACES	± .005	± .0001																		
2 PLACES	± 0.1	± .004																			
1 PLACE	± 0.3	± .012																			
<b>APPROVED BY</b> B.MOSER 2006/02/02	<b>DRAWN BY</b> L.PULLIAM 2006/01/31	<b>CHECKED BY</b> A.DHIR 2006/02/01	<b>DATE</b> 2006/02/02	<b>DATE</b> 2006/02/02	<b>MOLEX INCORPORATED</b>	<b>MX150 15MM BLADE TERMINAL</b>															
<b>MATERIAL NO.</b> <b>SEE TABLE</b>	<b>DOCUMENT NO.</b> SD-33000-001	<b>SIZE</b> C	<b>THIS DRAWING CONTAINS INFORMATION THAT IS PROPRIETARY TO MOLEX INCORPORATED AND SHOULD NOT BE USED WITHOUT WRITTEN PERMISSION</b>	<b>SHEET NO.</b> 4 OF 5																	
<b>INCORPORATED AND SHOULD NOT BE USED WITHOUT WRITTEN PERMISSION</b>																					

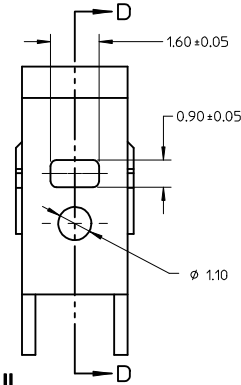
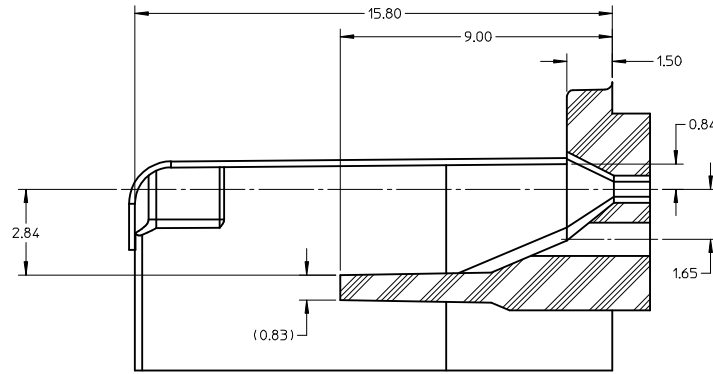
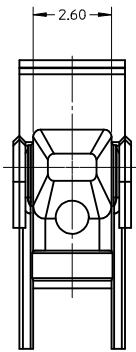

SECTION D-D

TPA/INSERT DETAIL

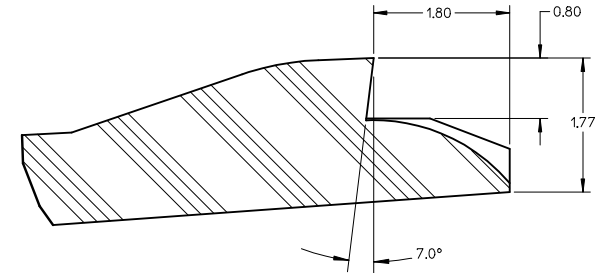
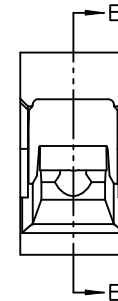
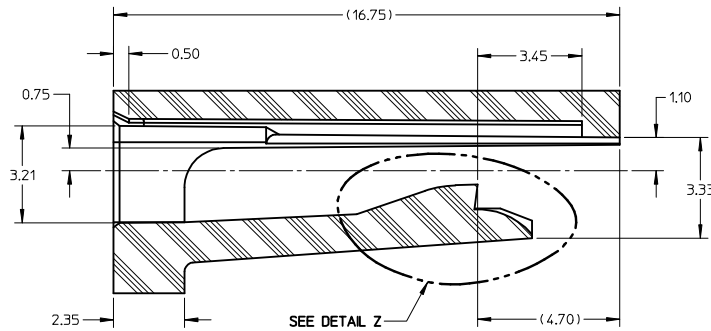
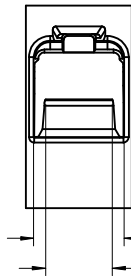

SECTION E-E

HOUSING DETAIL

DETAIL Z  
SCALE 20:1

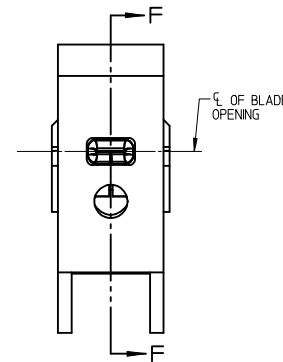
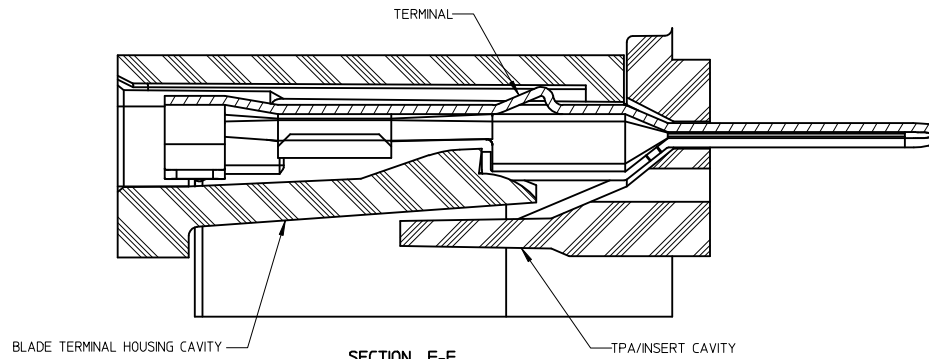
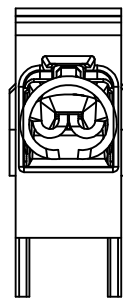

SECTION F-F

BLADE TERMINAL HOUSING CAVITY

SECTION F-F

TPA/INSERT CAVITY

NOTES: (UNLESS OTHERWISE SPECIFIED)

1. TOLERANCES: LINEAR  $\pm 0.10$   
ANGULAR  $3^\circ$
2. ALL DRAFT WITHIN TOLERANCE
3. MAX RADII ON ALL CORNERS SHOWN SHARP: 0.10
4. MAX FLASH PERMISSIBLE: 0.1
5. EJECTOR PIN MARKS PERMISSIBLE IF FLUSH TO 0.25 BELOW SURFACE
6. MATERIAL: HOUSING/FINGER SPECIFICATION ENGINEERED FOR MATERIAL WITH THE FOLLOWING PROPERTIES:  
A. FLEXURAL MODULUS = 4,500 TO 9,400 MPa  
PER ASTM TEST D790  
B. ELONGATION AT YIELD = 2.3% OR BETTER  
PER ASTM TEST D638 TYPE V
7. CAVITY SPEC FOR USE ONLY WITH MOLEX BLADE TERMINAL PART NUMBERS (EXCEPT P/N'S FOR UNSEALED APPLICATIONS) SPECIFIED ELSEWHERE ON THIS DRAWING

BLADE CAVITY ASSEMBLY VIEWS

<b>ENTER DESCRIPTION</b> EC NO: UAU2010-0107 DRAWN: FERUGSON 2009/08/18 CHKD: A.DHIR 2009/08/19 APPR: B.MOSER 2009/08/20 REV: C10	<b>QUALITY SYMBOLS</b> $\nabla=0$ $\nabla=0$	<b>GENERAL TOLERANCES (UNLESS SPECIFIED)</b>		<b>DIMENSION STYLE</b> MM ONLY	<b>SCALE</b> 8:1	<b>DESIGN UNITS</b> METRIC	THIRD ANGLE PROJECTION		
		4 PLACES $\pm 0.1$	3 PLACES $\pm 0.15$	2 PLACES $\pm 0.25$	1 PLACE $\pm 0.3$	DRAWN BY L.PULLIAM 2006/01/31	CHECKED BY A.DHIR 2006/02/01	APPROVED BY B.MOSER 2006/02/02	<b>TITLE</b> MX150 15MM BLADE TERMINAL
		ANGULAR $\pm 3^\circ$				MATERIAL NO. SEE TABLE	DOCUMENT NO. SD-33000-001	SHEET NO. 5 OF 5	
		THIS DRAWING CONTAINS INFORMATION THAT IS PROPRIETARY TO MOLEX INCORPORATED AND SHOULD NOT BE USED WITHOUT WRITTEN PERMISSION							