

**FEATURES**

- InGaP HBT Technology
- High Efficiency:  
 40 % @ +28 dBm output  
 22 % @ +17 dBm output
- Low Quiescent Current: 15 mA
- Low Leakage Current in Shutdown Mode: <1  $\mu$ A
- Internal Voltage Regulation
- Optimized for a 50  $\Omega$  System
- Low Profile Miniature Surface Mount Package:  
 1 mm
- CDMA 1XRTT, 1xEV-DO Compliant
- Pinout Enables Easy Phone Board Migration  
 From 4 mm x 4 mm Package
- RoHS-Compliant Package, 250 °C MSL-3

**APPLICATIONS**

- CDMA/EVDO AWS/KPCS band Wireless Handsets and Data Devices

**PRODUCT DESCRIPTION**

The AWT6309 meets the increasing demands for higher efficiency and smaller footprint in CDMA 1X handsets. The package pinout was chosen to enable handset manufacturers to switch from a 4 mm x 4 mm PA module with few layout changes while reducing board area requirements by 44%. The AWT6309 uses ANADIGICS' exclusive InGaP-Plus™ technology, which combines HBT and pHEMT devices on the same die, to enable state-of-the-art reliability, temperature stability, and ruggedness. The AWT6309 is part of ANADIGICS' High-Efficiency-at-Low-Power (HELP™) family of CDMA power amplifiers, which deliver low quiescent currents and significantly greater efficiency without a costly external DAC or DC-DC converter. Through selectable bias modes, the AWT6309 achieves optimal efficiency across different output power levels, specifically at low- and mid-range power levels where the PA typically operates, thereby dramatically increasing handset talk-time and standby-time. Its built-in voltage regulator eliminates the need for external voltage regulation components. The 3 mm x 3 mm x 1 mm surface mount package incorporates matching networks optimized for output power, efficiency, and linearity in a 50  $\Omega$  system.

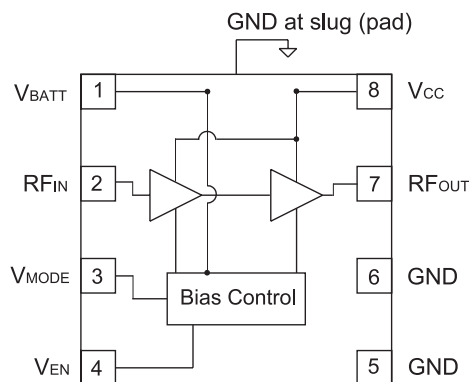
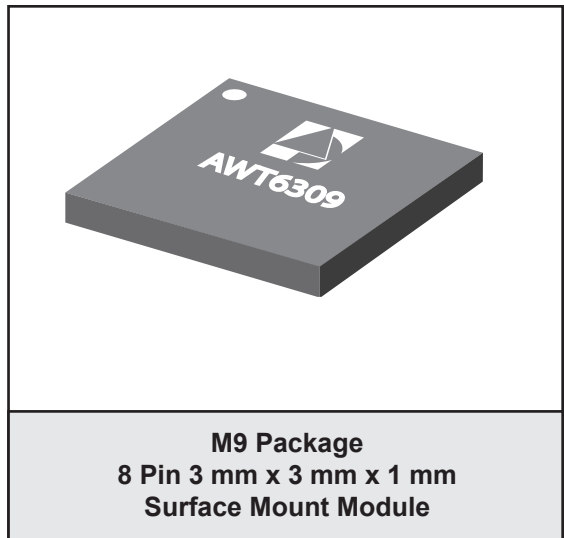

**Figure 1: Block Diagram**

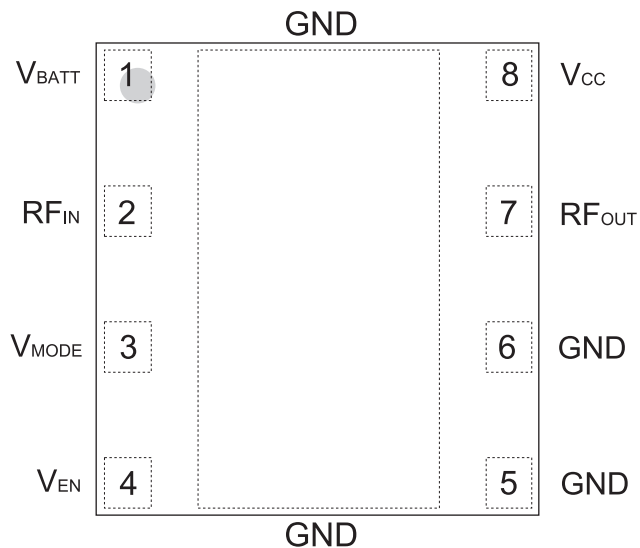

Figure 2: Pinout (X-ray Top View)

Table 1: Pin Description

PIN	NAME	DESCRIPTION
1	$V_{BATT}$	Battery Voltage
2	$RF_{IN}$	RF Input
3	$V_{MODE}$	Mode Control Voltage
4	$V_{EN}$	PA Enable Voltage
5	GND	Ground
6	GND	Ground
7	$RF_{OUT}$	RF Output
8	$V_{CC}$	Supply Voltage

## ELECTRICAL CHARACTERISTICS

Table 2: Absolute Minimum and Maximum Ratings

PARAMETER	MIN	MAX	UNIT
Supply Voltage ( $V_{CC}$ and $V_{BATT}$ )	0	+5	V
Mode Control Voltage ( $V_{MODE}$ )	0	+3.5	V
Enable Voltage ( $V_{EN}$ )	0	+3.5	V
RF Input Power ( $P_{IN}$ )	-	+10	dBm
Storage Temperature ( $T_{STG}$ )	-40	+150	°C

Stresses in excess of the absolute ratings may cause permanent damage. Functional operation is not implied under these conditions. Exposure to absolute ratings for extended periods of time may adversely affect reliability.

Table 3: Operating Ranges

PARAMETER	MIN	TYP	MAX	UNIT	COMMENTS
Operating Frequency (f)	1710	-	1780	MHz	
Supply Voltage ( $V_{CC}$ and $V_{BATT}$ )	+3.2	+3.4	+4.2	V	
Enable Voltage ( $V_{EN}$ )	+2.2 0	+2.4 -	+3.1 +0.5	V	PA "on" PA "shut down"
Mode Control Voltage ( $V_{MODE}$ )	+2.2 0	+2.4 -	+3.1 +0.5	V	Low Bias Mode High Bias Mode
RF Output Power ( $P_{OUT}$ )	27.5 <sup>(1)</sup>	+28.0	-	dBm	
Case Temperature ( $T_C$ )	-30	-	+85	°C	

The device may be operated safely over these conditions; however, parametric performance is guaranteed only over the conditions defined in the electrical specifications.

Notes:

(1) For operation at  $V_{CC} = +3.2$  V,  $P_{OUT}$  is derated by 0.5 dB.

**Table 4: Electrical Specifications - CDMA Operation**  
 (T<sub>C</sub> = +25 °C, V<sub>BATT</sub> = V<sub>CC</sub> = +3.4 V, V<sub>EN</sub> = +2.4 V, 50 Ω system, IS-95 uplink waveform)

PARAMETER	MIN	TYP	MAX	UNIT	COMMENTS
Gain	25 12.5 12.5	27.5 14.5 14.5	30 17 17	dB	P <sub>OUT</sub> = +28 dBm, V <sub>MODE</sub> = 0 V P <sub>OUT</sub> = +17 dBm, V <sub>MODE</sub> = +2.4 V P <sub>OUT</sub> = +18 dBm, V <sub>MODE</sub> = +2.4 V, V <sub>CC</sub> = +3.7 V
Adjacent Channel Power at +1.25 MHz offset Primary Channel BW = 1.23 MHz Adjacent Channel BW = 30 kHz	- - -	-50 -53 -52	-46.5 -46.5 -46.5	dBc	P <sub>OUT</sub> = +28 dBm, V <sub>MODE</sub> = 0 V P <sub>OUT</sub> = +17 dBm, V <sub>MODE</sub> = +2.4 V P <sub>OUT</sub> = +18 dBm, V <sub>MODE</sub> = +2.4 V, V <sub>CC</sub> = +3.7 V
Adjacent Channel Power at +1.98 MHz offset Primary Channel BW = 1.23 MHz Adjacent Channel BW = 30 kHz	- -	-56 -56	-53 -53	dBc	P <sub>OUT</sub> = +28 dBm, V <sub>MODE</sub> = 0 V P <sub>OUT</sub> = +17 dBm, V <sub>MODE</sub> = +2.4 V
Adjacent Channel Power at +2.25 MHz offset Primary Channel BW = 1.23 MHz Adjacent Channel BW = 30 kHz	- -	-61 -61	-57 -57	dBc	P <sub>OUT</sub> = +28 dBm, V <sub>MODE</sub> = 0 V P <sub>OUT</sub> = +17 dBm, V <sub>MODE</sub> = +2.4 V
Power-Added Efficiency	36 17	40 22	- -	%	P <sub>OUT</sub> = +28 dBm, V <sub>MODE</sub> = 0 V P <sub>OUT</sub> = +17 dBm, V <sub>MODE</sub> = +2.4 V
Quiescent Current (I <sub>cq</sub> )	-	15	18	mA	through V <sub>CC</sub> pin, V <sub>MODE</sub> = +2.4 V
Enable Current	-	0.3	0.6	mA	through V <sub>EN</sub> pin, PA "on"
Mode Control Current	-	0.3	0.6	mA	through V <sub>MODE</sub> pin, V <sub>MODE</sub> = +2.4 V
Battery Current	-	2.5	5	mA	through V <sub>BATT</sub> pin, V <sub>MODE</sub> = +2.4 V
Leakage Current	-	<1	5	μA	V <sub>CC</sub> = +4.2 V, V <sub>EN</sub> = 0 V, V <sub>MODE</sub> = 0 V
Noise in Receive Band	- - -	-134 -136 -136	-132 -134 -134	dBm/Hz	1840 MHz to 1870 MHz 2110 MHz to 2155 MHz 1574 MHz to 1577 MHz
Harmonics 2fo 3fo, 4fo	- -	-40 -55	-30 -30	dBc	
Input Impedance	-	-	2.3:1	VSWR	
Spurious Output Level (all spurious outputs)	-	-	-65	dBc	P <sub>OUT</sub> ≤ +28 dBm In-band load VSWR < 5:1 Out-of-band load VSWR < 10:1 Applies over all operating ranges
Load mismatch stress with no permanent degradation or failure	8:1	-	-	VSWR	Applies over full operating range

Notes:

1. ACPRs and Efficiency Limits apply at 1745 MHz (IS-95 modulation).

## APPLICATION INFORMATION

To ensure proper performance, refer to all related Application Notes on the ANADIGICS web site: <http://www.anadigics.com>

### Shutdown Mode

The power amplifier may be placed in a shutdown mode by applying logic low levels (see Operating Ranges table) to both the  $V_{EN}$  and  $V_{MODE}$  voltages.

### Bias Modes

The power amplifier may be placed in either a Low Bias mode or a High Bias mode by applying the appropriate logic level (see Operating Ranges table) to the  $V_{MODE}$  voltage. The Bias Control table lists the recommended modes of operation for various applications.

Table 5: Bias Control

APPLICATION	$P_{OUT}$ LEVELS	LOGIC	$V_{EN}$	$V_{MODE}$
CDMA - low power	$\leq +17$ dBm	Low	+2.4 V	+2.4 V
CDMA - high power	$> +17$ dBm	High	+2.4 V	0 V
Shutdown	-	Shutdown	0 V	0 V

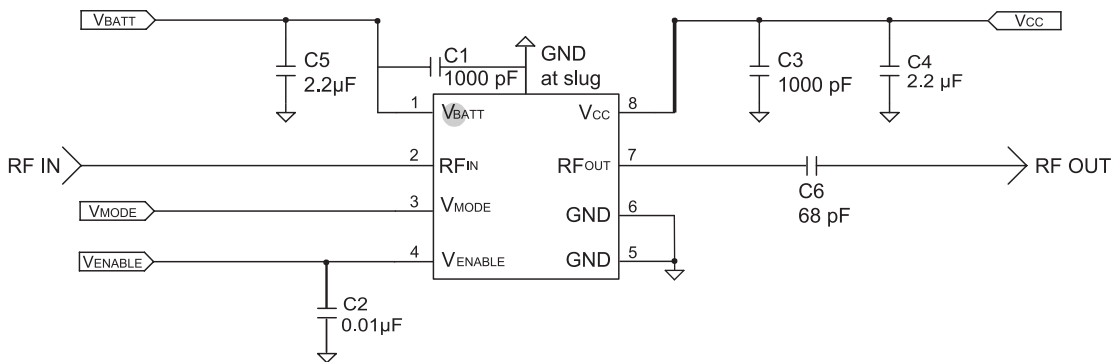
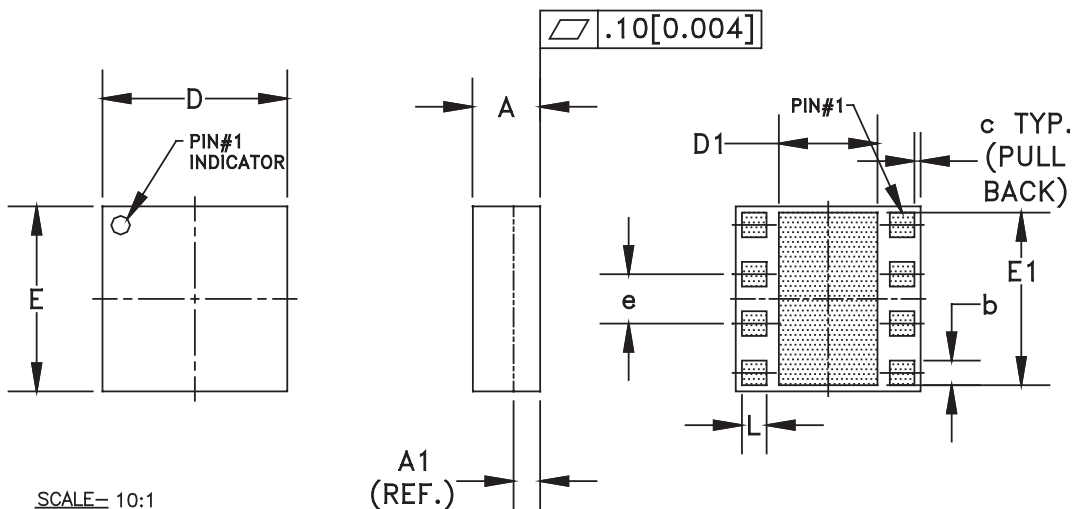

Figure 3: Application Circuit

PACKAGE OUTLINE



SCALE= 10:1

Symbol	MILLIMETERS			INCHES			NOTE
	MIN.	NOM.	MAX.	MIN.	NOM.	MAX.	
A	0.90	1.00	1.10	0.035	0.039	0.043	—
A1	0.35 (REF.)			0.013 (REF.)			—
b	0.35	—	0.60	0.013	—	0.024	3
c	—	0.10	—	—	0.004	—	—
D	2.88	3.00	3.12	0.113	0.118	0.123	—
D1	1.20	—	1.50	0.047	—	0.060	3
E	2.88	3.00	3.12	0.113	0.118	0.123	—
E1	2.75	—	2.85	0.108	—	0.112	3
e	0.80 BSC			0.0315 BSC			—
L	0.35	—	0.60	0.013	—	0.024	3

NOTES:

1. CONTROLLING DIMENSIONS: MILLIMETERS
2. UNLESS SPECIFIED TOLERANCE=±0.076[0.003].
3. PADS (INCLUDING CENTER) SHOWN UNIFORM SIZE FOR REFERENCE ONLY. ACTUAL PAD SIZE AND LOCATION WILL VARY WITHIN MIN. AND MAX. DIMENSIONS ACCORDING TO SPECIFIC LAMINATE DESIGN.
4. UNLESS SPECIFIED DIMENSIONS ARE SYMMETRICAL ABOUT CENTER LINES SHOWN.

Figure 4: M9 Package Outline - 8 Pin 3 mm x 3 mm x 1 mm Surface Mount Module

TOP BRAND



NOTES:

1. ANADIGICS LOGO SIZE: NONE
2. PART NUMBER: FOUR DIGIT NUMERICAL
3. WAFER LOT NUMBER: LLLL = LOT NUMBER  
NN = WAFER I.D.
4. PIN 1 INDICATOR: LASER DOT
5. B.O.M. #: 091
6. COUNTRY CODE: CC = TH-for-THAILAND, TW-for-TAIWAN  
CC = PH-for-PHILIPPINES, CH-for-CHINA  
CC = KR-for-KOREA
7. TYPE : ARIAL  
SIZE : 1.5-POINT  
COLOR : LASER

Figure 5: Branding Specification

COMPONENT PACKAGING

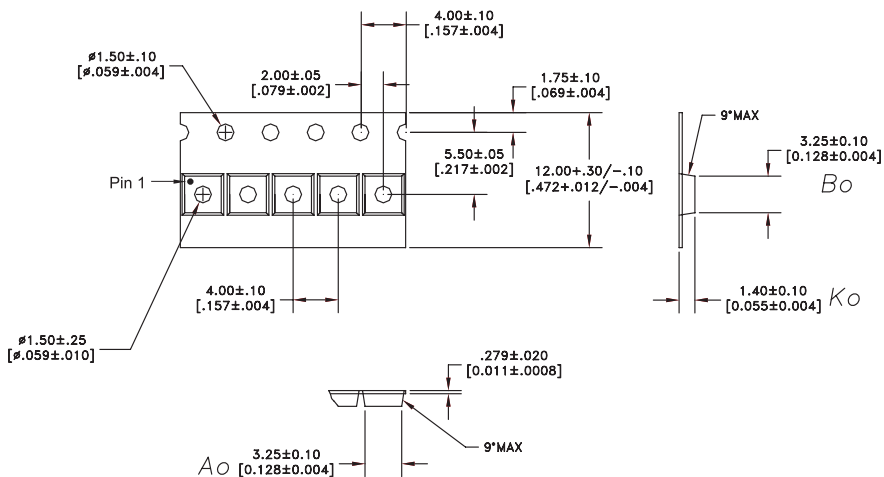

NOTES:

1. MATERIAL: 3000 (CARBON FILLED POLYCARBONATE)  
100% RECYCLABLE.

DIMENSIONS ARE IN MILLIMETERS [INCHES]

*DIMENSIONING AND TOLERANCING PER ASME Y14.5M-1994*

Figure 6: Tape & Reel Packaging

Table 6: Tape & Reel Dimensions

PACKAGE TYPE	TAPE WIDTH	POCKET PITCH	REEL CAPACITY	MAX REEL DIA
3 mm x 3 mm x 1 mm	12 mm	4 mm	2500	7"

## ORDERING INFORMATION

ORDER NUMBER	TEMPERATURE RANGE	PACKAGE DESCRIPTION	COMPONENT PACKAGING
AWT6309RM9Q7	-30 °C to +85 °C	RoHS-Compliant 8 Pin 3 mm x 3 mm x 1 mm Surface Mount Module	Tape and Reel, 2500 pieces per Reel
AWT6309RM9P9	-30 °C to +85 °C	RoHS-Compliant 8 Pin 3 mm x 3 mm x 1 mm Surface Mount Module	Partial Tape and Reel

**ANADIGICS, Inc.**

141 Mount Bethel Road  
Warren, New Jersey 07059, U.S.A.

Tel: +1 (908) 668-5000

Fax: +1 (908) 668-5132

URL: <http://www.anadigics.com>

E-mail: [Mktg@anadigics.com](mailto:Mktg@anadigics.com)

**IMPORTANT NOTICE**

ANADIGICS, Inc. reserves the right to make changes to its products or to discontinue any product at any time without notice. The product specifications contained in Advanced Product Information sheets and Preliminary Data Sheets are subject to change prior to a product's formal introduction. Information in Data Sheets have been carefully checked and are assumed to be reliable; however, ANADIGICS assumes no responsibilities for inaccuracies. ANADIGICS strongly urges customers to verify that the information they are using is current before placing orders.

**WARNING**

ANADIGICS products are not intended for use in life support appliances, devices or systems. Use of an ANADIGICS product in any such application without written consent is prohibited.