

NN5118160A / NN5118160B series

Fast Page Mode

CMOS 1M × 16bit Dynamic RAM



DESCRIPTION

The NN5118160A / NN5118160B series is a high performance CMOS Dynamic Random Access Memory organized as 1,048,576 words by 16 bits. The NN5118160A / B series is fabricated with advanced CMOS technology and designed with innovative design techniques resulting in high speed, extremely low power and wide operating margins at both component and system levels.

The NN5118160A / NN5118160B features a high speed page mode operation in which a high speed read, write or read-write is performed on any column address along a row address.

An extremely short row address capture time and an asynchronous column address decoder relax the timing constraints associated with address multiplexing.

The outputs are tri-stated by $\overline{\text{CAS}}$ which, in essence, acts as an output enable independent of $\overline{\text{RAS}}$ with very fast $\overline{\text{CAS}}$ to output access time.

Refresh is accomplished by performing $\overline{\text{RAS}}$ only refresh cycles, hidden refresh cycles, $\overline{\text{CAS}}$ before $\overline{\text{RAS}}$ refresh cycles, or normal read or write cycles on the 1024 address combinations of A0 to A9 during a 16 ms period.

Multiplexed address inputs permit the NN5118160A / NN5118160B to be packaged in a standard 42-pin plastic SOJ, 50-pin plastic TSOP TYPE II. The package sizes provide high system bit densities. System level features include single power supply of 5V ±10% tolerance and direct interface with high performance TTL logic families.

FEATURES

- 1,048,576 × 16 bit Organization
- Single 5V ±10% Power Supply
- Performance Ranges

NN5118160A

Parameter	-50	-60	-70
Max. $\overline{\text{RAS}}$ Access Time (t_{RAC})	50ns	60ns	70ns
Max. $\overline{\text{CAS}}$ Access Time (t_{CAC})	15ns	15ns	20ns
Max. Column Address Access Time (t_{AA})	25ns	30ns	35ns
Max. Read/Write Cycle Time (t_{RC})	100ns	110ns	130ns

NN5118160B

Parameter	-40	-50	-60
Max. $\overline{\text{RAS}}$ Access Time (t_{RAC})	40ns	50ns	60ns
Max. $\overline{\text{CAS}}$ Access Time (t_{CAC})	11ns	13ns	15ns
Max. Column Address Access Time (t_{AA})	20ns	25ns	30ns
Min. Read/Write Cycle Time (t_{RC})	80ns	90ns	110ns

- Fast Page Mode Operation
- Separate $\overline{\text{CAS}}$ ($\overline{\text{UCAS}}$, $\overline{\text{LCAS}}$) for Byte Selection
- Byte Read/Write Mode Operation
- Low Power Operation
 - Low Standby Current (CMOS level input)
 - Standard 1mA
 - L version 150μA
- 1024 Refresh Cycles
 - Standard 16ms
 - L version 128ms
- Self Refresh Mode (L version)
- All inputs/Outputs and Clocks fully TTL and CMOS compatible
- Refresh Modes
 - $\overline{\text{RAS}}$ only
 - $\overline{\text{CAS}}$ before $\overline{\text{RAS}}$
 - Hidden Refresh
- High Reliability Package
 - Plastic 42pin SOJ (P42SJ-2B-L)
 - Plastic 50pin TSOP TYPE II (P50/44TP-3B-L)

9005650 0000940 659

PIN CONFIGURATION

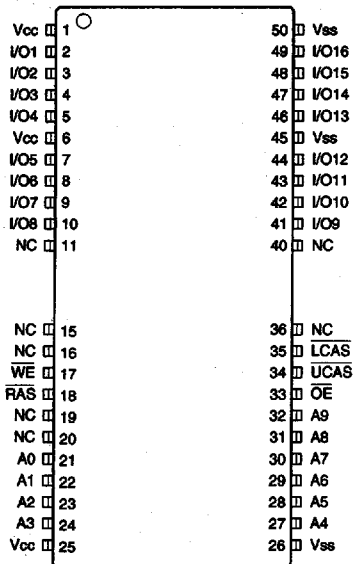

50/44-pin TSOP TYPE (II)
 Normal Bend (400mil)
 P50/44TP-3B-L

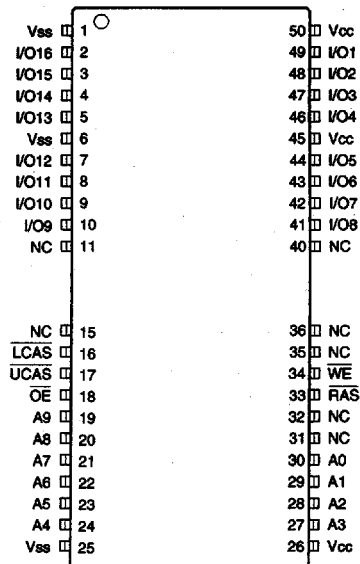

50/44-pin TSOP TYPE (II)
 Reverse Bend (400mil)
 P50/44TP-3B-L

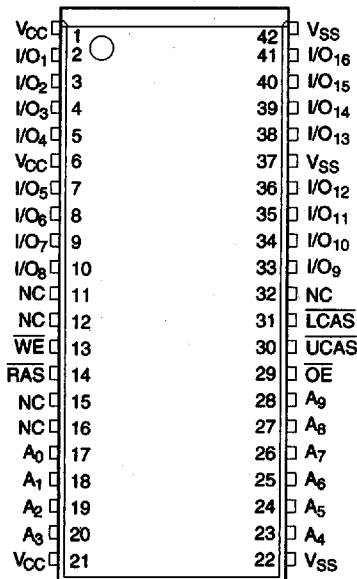

42-pin SOJ (400mil)
 P42SJ-2B-L

PIN NAMES

A0-A9	Address Inputs
RAS	Row Address Strobe
UCAS	Column Address Strobe Upper Byte Control
LCAS	Column Address Strobe Lower Byte Control
OE	Output Enable
I/O1-I/O16	Data-in / Data-out
WE	Write Enable
Vcc	+5V Supply
Vss	Ground
NC	No Connection

FUNCTIONAL BLOCK DIAGRAM

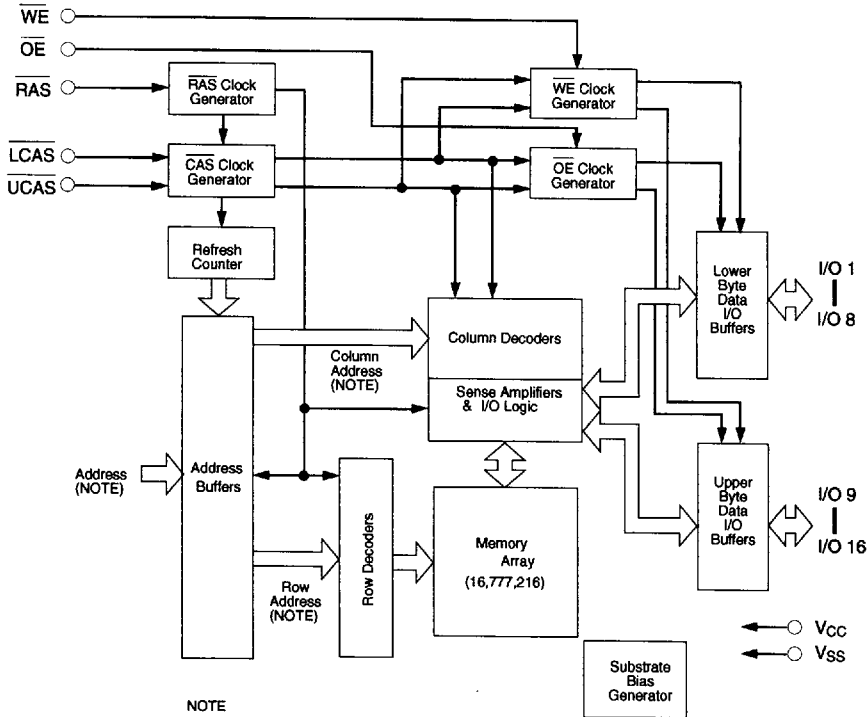

NOTE

Address / Row Address	Column Address
A0 - A9	A0 - A9

ABSOLUTE MAXIMUM RATINGS

RATING	SYMBOL	VALUE	UNIT
Voltage on Any Pin Relative to V_{SS}	V_{in}, V_{out}	-1 to 7	V
Voltage on V_{CC} Relative to V_{SS}	V_{CC}	-1 to 7	V
Storage Temperature (Plastic)	T_{stg}	-55 to +125	°C
Power Dissipation	P_d	1.0	W
Ambient Operating Temperature	T_a	0 to +70	°C
Short Circuit Output Current	I_{out}	50	mA

Permanent device damage can occur if absolute maximum ratings are exceeded. Functional operation should be restricted to the conditions as detailed in the operational sections of this data sheet. Exposure to absolute maximum rating conditions for extended periods can affect device reliability.

DC OPERATING CONDITIONS

SYMBOL	PARAMETER	MIN.	TYP.	MAX.	UNIT
V_{CC}	Supply Voltage	4.5	5.0	5.5	V
V_{SS}	Supply Voltage	0	0	0	V
V_{IH}	Input High Voltage, All Inputs	2.4	—	6.5	V
V_{IL}	Input Low Voltage, All Inputs	-1.0	—	0.8	V

Note: All voltage values in this data sheet are with respect to V_{SS} unless otherwise specified.

TRUTH TABLE

INPUTS					I/O		OPERATION	NOTES
$\overline{\text{RAS}}$	$\overline{\text{LCAS}}$	$\overline{\text{UCAS}}$	$\overline{\text{WE}}$	$\overline{\text{OE}}$	I/O1~I/O8	I/O9~I/O16		
H	H	H	H	H	High-Z	High-Z	Standby	1,3
L	H	H	H	H	High-Z	High-Z	Refresh	1,3
L	L	H	H	L	Dout	High-Z	Lower byte read	1,3
L	H	L	H	L	High-Z	Dout	Upper byte read	1,3
L	L	L	H	L	Dout	Dout	Word read	1,3
L	L	H	L	H	Din	Don't care	Lower byte write	1,2,3
L	H	L	L	H	Don't care	Din	Upper byte write	1,2,3
L	L	L	L	H	Din	Din	Word write	1,2,3
L	L	L	H	H	High-Z	High-Z		1,3
H→L	L	H	H	—	High-Z	High-Z	CBR refresh or Self refresh	1,3
H→L	H	L	H	—	High-Z	High-Z		
H→L	L	L	H	—	High-Z	High-Z		

Notes: 1. H:high (inactive) , L:low (active) , —:unconcerned with H or L.

2. $t_{wCS} \geq 0ns$: early write mode.

$t_{wCS} < 0ns$: OE controlled write mode.

3. Operation mode is set by the earliest of LCAS and UCAS active edge and reset by the latest of $\overline{\text{LCAS}}$ and $\overline{\text{UCAS}}$ inactive edge.

However write operation and High-Z control are done independently by each $\overline{\text{LCAS}}$, $\overline{\text{UCAS}}$.

DC ELECTRICAL CHARACTERISTICS (0°C ≤ Ta ≤ 70°C, V_{CC} = 5.0V ±10%)
(NN5118160A)

SYMBOL	PARAMETER	SPEED	MIN.	MAX.	UNIT	TEST CONDITIONS	NOTES
I _{CC1}	Operating Current	-50		190	mA	t _{RC} = t _{RC} (min.) RAS, CAS, Address cycling	1, 2
		-60		170	mA		
		-70		150	mA		
I _{CC2}	Standby Current			1.0	mA	$\overline{\text{RAS}} = \overline{\text{CAS}} \geq (V_{\text{CC}} - 0.2\text{V})$	
				2.0	mA	$\overline{\text{RAS}} = \overline{\text{CAS}} \geq V_{\text{IH}}$	
	Standby Current (L version)			250	μA	$\overline{\text{RAS}} = \overline{\text{CAS}} \geq (V_{\text{CC}} - 0.2\text{V})$ All other inputs are stable at (V _{CC} - 0.2V) or (V _{SS} + 0.2V)	
I _{CC3}	Refresh Current (RAS only refresh)	-50		190	mA	t _{RC} = t _{RC} (min.) RAS cycling, $\overline{\text{CAS}} = V_{\text{IH}}$	1
		-60		170	mA		
		-70		150	mA		
I _{CC4}	Fast Page Mode Current	-50		120	mA	t _{PC} = t _{PC} (min.) RAS = V _{IL} CAS, Address cycling	1, 2
		-60		110	mA		
		-70		100	mA		
I _{CC5}	Refresh Current (CAS before RAS refresh)	-50		190	mA	t _{RC} = t _{RC} (min.) RAS, CAS cycling	1
		-60		170	mA		
		-70		150	mA		
I _{CC6}	Refresh Current (L version : $\overline{\text{CAS}}$ before RAS refresh)			500	μA	1024 cycles / 128ms t _{RAS} ≤ 200ns, WE ≥ (V _{CC} - 0.2V) All other inputs are stable at (V _{CC} - 0.2V) or (V _{SS} + 0.2V)	
I _{CC7}	Self Refresh Mode Current (L version)			300	μA	$\overline{\text{RAS}} = \overline{\text{CAS}} \leq (V_{\text{SS}} + 0.2\text{V})$ All other input high levels are (V _{CC} - 0.2V) or input low levels are (V _{SS} + 0.2V)	
I _{L1}	Input Leakage Current (Any input pin)		-10	10	μA	0V ≤ V _{IH} ≤ 5.5V, Others = 0V	
I _{L0}	Output Leakage Current (For high impedance state)		-10	10	μA	$\overline{\text{RAS}} \geq V_{\text{IH}}(\text{min.}), \overline{\text{CAS}} \geq V_{\text{IH}}(\text{min.})$ 0V ≤ V _{OUT} ≤ 5.5V	
V _{OH}	Output High Voltage		2.4		V	I _{OH} = -5.0 mA	
V _{OL}	Output Low Voltage			0.4	V	I _{OL} = 4.2 mA	

Notes: 1. I_{CC1}, I_{CC3}, I_{CC4} and I_{CC5} depend on cycle rate.

2. I_{CC1} and I_{CC4} depend on output loading. Specified values are obtained with the outputs open.

CAPACITANCE (0°C ≤ Ta ≤ 70°C, V_{CC} = 5.0V ±10%, f = 1MHz)

SYMBOL	PARAMETER	MIN.	MAX.	UNIT
C _{IN1}	Address(A0 ~ A9)	—	5	pF
C _{IN2}	$\overline{\text{RAS}}, \overline{\text{LCAS}}, \overline{\text{UCAS}}, \overline{\text{WE}}, \overline{\text{OE}}$	—	5	pF
C _{OUT}	I/O1 ~ I/O16	—	7	pF

NN5118160A / NN5118160B series
CMOS 1M × 16bit Dynamic RAM

DC ELECTRICAL CHARACTERISTICS (0°C ≤ Ta ≤ 70°C, V_{CC} = 5.0V ±10%)
(NN5118160B)

SYMBOL	PARAMETER	SPEED	MIN.	MAX.	UNIT	TEST CONDITIONS	NOTES
I _{CC1}	Operating Current	-40		200	mA	t _{RC} = t _{RC} (min.) RAS, CAS, Address cycling	1, 2
		-50		180	mA		
		-60		160	mA		
I _{CC2}	Standby Current			1.0	mA	RAS = CAS ≥ (V _{CC} - 0.2V)	
				2.0	mA	RAS = CAS ≥ V _{IH}	
	Standby Current (L version)			150	μA	RAS = CAS ≥ (V _{CC} - 0.2V) All other inputs are stable at (V _{CC} - 0.2V) or (V _{SS} + 0.2V)	
I _{CC3}	Refresh Current (RAS only refresh)	-40		200	mA	t _{RC} = t _{RC} (min.) RAS cycling, CAS = V _{IH}	1
		-50		180	mA		
		-60		160	mA		
I _{CC4}	Fast Page Mode Current	-40		110	mA	t _{PC} = t _{PC} (min.) RAS = V _{IL} CAS, Address cycling	1,2
		-50		100	mA		
		-60		90	mA		
I _{CC5}	Refresh Current (CAS before RAS refresh)	-40		200	mA	t _{RC} = t _{RC} (min.) RAS, CAS cycling	1
		-50		180	mA		
		-60		160	mA		
I _{CC6}	Refresh Current (L version : CAS before RAS refresh)			500	μA	1,024 cycles / 128ms t _{RAS} ≤ 200ns, WE ≥ (V _{CC} - 0.2V) All other inputs are stable at (V _{CC} - 0.2V) or (V _{SS} + 0.2V)	
I _{CC7}	Self Refresh Mode Current (L version)			300	μA	RAS = CAS ≤ (V _{SS} + 0.2V) All other input high levels are (V _{CC} - 0.2V) input low levels are (V _{SS} + 0.2V)	
I _{L1}	Input Leakage Current (Any input pin)		-10	10	μA	0V ≤ V _{IH} ≤ 5.5V, Others = 0V	
I _{L0}	Output Leakage Current (For high impedance state)		-10	10	μA	RAS ≥ V _{IH} (min.), CAS ≥ V _{IH} (min.) 0V ≤ V _{OUT} ≤ 5.5V	
V _{OH}	Output High Voltage		2.4		V	I _{OH} = -5.0 mA	
V _{OL}	Output Low Voltage			0.4	V	I _{OL} = 4.2 mA	

- Notes: 1. I_{CC1}, I_{CC3}, I_{CC4} and I_{CC5} depend on cycle rate.
2. I_{CC1} and I_{CC4} depend on output loading. Specified values are obtained with the outputs open.

CAPACITANCE (0°C ≤ Ta ≤ 70°C, V_{CC} = 5.0V ±10%, f = 1MHz)

SYMBOL	PARAMETER	MIN.	MAX.	UNIT
C _{IN1}	Address(A0 ~ A9)	—	5	pF
C _{IN2}	RAS, LCAS, UCAS, WE, OE	—	5	pF
C _{OUT}	I/O1 ~ I/O16	—	7	pF

9005650 0000945 130

AC ELECTRICAL CHARACTERISTICS (NN5118160A)

Test conditions : $V_{IH}/V_{IL} = 2.4V / 0.8V$ $V_{OH}/V_{OL} = 2.4V / 0.4V$ output loading $C_L = 100pF + 2TTL$
Operating conditions : ($0^\circ C \leq T_a \leq 70^\circ C$, $V_{CC} = 5.0V \pm 10\%$, $V_{SS} = 0V$) (NOTES 3, 4, 5)

NO.	SYMBOL		PARAMETER	-50		-60		-70		UNIT	NOTE
	JEDEC	STD		MIN.	MAX.	MIN.	MAX.	MIN.	MAX.		
1	t_{CL1QV}	t_{CAC}	Access Time from \overline{CAS}	—	15	—	15	—	20	ns	6,13
2	t_{CH2QV}	t_{CPA}	Access Time from \overline{CAS} Precharge	—	30	—	35	—	40	ns	13,14
3	t_{AVQV}	t_{AA}	Access Time from Column Address	—	25	—	30	—	35	ns	7,13
4	t_{RL1QV}	t_{RAC}	Access Time from \overline{RAS}	—	50	—	60	—	70	ns	6,7
5	t_{RL1CH1}	t_{CSH}	\overline{CAS} Hold Time	50	—	60	—	70	—	ns	
6	t_{RL1CH1}	t_{CHR}	\overline{CAS} Hold Time (\overline{CAS} before \overline{RAS} Refresh)	10	—	10	—	10	—	ns	
7	t_{RL1CX}	t_{CHS}	\overline{CAS} Precharge Time (Self Refresh Mode)	-50	—	-50	—	-50	—	ns	
8	t_{CH2CL2}	t_{CPN}	\overline{CAS} Precharge Time (\overline{CAS} before \overline{RAS} Refresh)	10	—	10	—	10	—	ns	
9	t_{CH2CL2}	t_{CP}	\overline{CAS} Precharge Time (Fast Page Mode)	5	—	5	—	5	—	ns	14
10	t_{CL1CH1}	t_{CAS}	\overline{CAS} Pulse Width	15	100K	15	100K	20	100K	ns	
11	t_{CL1RL2}	t_{CSR}	\overline{CAS} Setup Time (\overline{CAS} before \overline{RAS} Refresh)	5	—	5	—	5	—	ns	
12	t_{CL1QX}	t_{CLZ}	\overline{CAS} to Output in Low-Z	0	—	0	—	0	—	ns	8
13	t_{CH2RL2}	t_{CRP}	\overline{CAS} to \overline{RAS} Precharge Time	5	—	5	—	5	—	ns	
14	t_{CL1WL2}	t_{CWD}	\overline{CAS} to \overline{WE} Delay Time	32	—	37	—	42	—	ns	11
15	t_{CL1AX}	t_{CAH}	Column Address Hold Time	7	—	10	—	12	—	ns	
16	t_{RL1AX}	t_{AR}	Column Address Hold Time Referenced to \overline{RAS}	35	—	40	—	40	—	ns	
17	t_{AVCL2}	t_{ASC}	Column Address Setup Time	0	—	0	—	0	—	ns	14
18	t_{AVRH1}	t_{RAL}	Column Address to \overline{RAS} Lead Time	27	—	30	—	35	—	ns	
19	t_{AVWL2}	t_{AWD}	Column Address to \overline{WE} Delay Time	39	—	47	—	54	—	ns	11
20	t_{CL1DX} t_{WL1DX}	t_{DH}	Data Hold Time	10	—	10	—	15	—	ns	12
21	t_{DVCL2} t_{DVWL2}	t_{DS}	Data Setup Time	0	—	0	—	0	—	ns	12
22	t_{OL1QV}	t_{OEA}	\overline{OE} Access Time	—	15	—	15	—	20	ns	
23	t_{WL1OL2}	t_{OEH}	\overline{OE} Command Hold Time	15	—	15	—	20	—	ns	
24	t_{CH2QV}	t_{OED}	\overline{OE} to Data Delay Time	15	—	15	—	20	—	ns	
25	t_{CH2OZ}	t_{OFF}	Output Buffer Turn-off Delay Time	0	13	0	15	0	20	ns	10
26	t_{OH2OX}	t_{OEZ}	Output Buffer Turn-off Delay Time Referenced to \overline{OE}	0	15	0	15	0	20	ns	
27	t_{CL1RH1}	t_{RSH}	\overline{RAS} Hold Time	15	—	15	—	20	—	ns	
28	t_{OL1RH1}	t_{ROH}	\overline{RAS} Hold Time Referenced to \overline{OE}	10	—	10	—	10	—	ns	
29	t_{RH2RL2}	t_{RP}	\overline{RAS} Precharge Time	25	—	30	—	40	—	ns	
30	t_{RH2RL2}	t_{RPS}	\overline{RAS} Precharge Time (Self Refresh Mode)	100	—	110	—	130	—	ns	
31	t_{RL1RH1}	t_{RAS}	\overline{RAS} Pulse Width	50	100K	60	100K	70	100K	ns	
32	t_{RL1RH1}	t_{RASP}	\overline{RAS} Pulse Width (Fast Page Mode)	50	100K	60	100K	70	100K	ns	
33	t_{RL1RH1}	t_{RASS}	\overline{RAS} Pulse Width (Self Refresh Mode)	300	—	300	—	300	—	μs	
34	t_{RL1CL1}	t_{RCD}	\overline{RAS} to \overline{CAS} Delay Time	13	35	13	45	13	50	ns	6
35	t_{RH2CL2}	t_{RPC}	\overline{RAS} to \overline{CAS} Precharge Time	0	—	0	—	0	—	ns	
36	t_{RL1AV}	t_{RAD}	\overline{RAS} to Column Address Delay Time	11	23	11	30	11	35	ns	7
37	t_{RL1WL2}	t_{RWD}	\overline{RAS} to \overline{WE} Delay Time	64	—	77	—	89	—	ns	11

NN5118160A / NN5118160B series
CMOS 1M × 16bit Dynamic RAM

NO.	SYMBOL		PARAMETER	-50		-60		-70		UNIT	NOTE
	JEDEC	STD		MIN.	MAX.	MIN.	MAX.	MIN.	MAX.		
38	t _{CH2WL2}	t _{RCH}	Read Command Hold Time	0	—	0	—	0	—	ns	9
39	t _{RH2WL2}	t _{RRH}	Read Command Hold Time Referenced to RAS	0	—	0	—	0	—	ns	9
40	t _{WH2CL2}	t _{RCS}	Read Command Setup Time	0	—	0	—	0	—	ns	
41	t _{RL2RL2}	t _{RC}	Random Read or Write Cycle Time	100	—	110	—	130	—	ns	
42	t _{CL2CL2}	t _{PC}	Read or Write Cycle Time (Fast Page Mode)	33	—	40	—	45	—	ns	13,14
43	t _{RL2RL2}	t _{RMW}	Read-Modify-Write Cycle Time	120	—	140	—	160	—	ns	
44	t _{CL2CL2}	t _{PRMW}	Read-Modify-Write Cycle Time (Fast Page Mode)	80	—	85	—	95	—	ns	13,14
45	t _{REF}	t _{REF}	Refresh Period	—	16	—	16	—	16	ms	15
46	t _{RL1AX}	t _{RAH}	Row Address Hold Time	8	—	10	—	10	—	ns	
47	t _{AVRL2}	t _{ASR}	Row Address Setup Time	0	—	0	—	0	—	ns	
48	t _T	t _T	Transition Time (Rise and Fall)	2	50	2	50	2	50	ns	4,5
49	t _{CL1WH1}	t _{WCH}	Write Command Hold Time	10	—	10	—	15	—	ns	
50	t _{WL1WH1}	t _{WP}	Write Command Pulse Width	10	—	10	—	15	—	ns	
51	t _{WL1CL2}	t _{WCS}	Write Command Setup Time	0	—	0	—	0	—	ns	11
52	t _{WL1CH1}	t _{CWL}	Write Command to CAS Lead Time	15	—	15	—	20	—	ns	
53	t _{WL1RH1}	t _{RWL}	Write Command to RAS Lead Time	15	—	15	—	20	—	ns	
54	t _{WH2RL2}	t _{WRP}	WE to RAS Precharge Time (CAS before RAS refresh)	10	—	10	—	10	—	ns	
55	t _{RL1WH2}	t _{WRH}	WE to RAS Hold Time (CAS before RAS refresh)	10	—	10	—	10	—	ns	

Notes:

- Eight Initialization Cycles are required following a 200μs pause after Power Up. These Initialization Cycles may consist of any combination of the following : RAS only refresh Cycles, Read Cycles, Write Cycles, CAS before RAS refresh Cycles.
- AC measurements assume t_T=3ns. All AC parameters are measured with V_{IL}(min.)≥V_{SS} and V_{IH}(max.)≤V_{CC} and with a load equivalent to two TTL loads and 100pF.
- V_{IH}(min.) and V_{IL}(max.) are reference levels for measuring timing of input signals. Also, transition times are measured between V_{IH} and V_{IL}.
- Operation within the t_{RCD}(max.) limit ensures that t_{RAC}(max.) can be met. t_{RCD}(max.) is specified as a reference point only. If t_{RCD} is greater than the specified t_{RCD}(max.) limit, then access time is controlled by t_{CAC}.
- Operation within the t_{RAD}(max.) limit ensures that t_{RAC}(max.) can be met. t_{RAD}(max.) is specified as a reference point only. If t_{RAD} is greater than the specified t_{RAD}(max.) limit, then access time is controlled by t_{AA}.
- Assumes three state test load (5pF and a 220 ohm to 1.3V Thevenin equivalent).
- Either t_{RCH} or t_{RRH} must be satisfied for a read cycle.
- t_{OFF}(max.) defines the time at which the output achieves an open circuit condition and is not referenced to output voltage levels.
- t_{WCS}, t_{RWD}, t_{CWD} and t_{AWD} are not restrictive operating parameters. They are included in the data sheet as electrical characteristics only. If t_{WCS}≥t_{WCS}(min.), the cycle is an early write cycle and data-out pins will remain open circuit (high impedance) throughout the entire cycle. If t_{RWD}≥t_{RWD}(min.), t_{CWD}≥t_{CWD}(min.) and t_{AWD}≥t_{AWD}(min.), the cycle is a read-modify-write cycle and the data-out will contain data read from the selected cell. If neither of the above conditions is satisfied, the condition of the data-out (at access time) is indeterminate.
- These parameters are referenced to $\overline{\text{CAS}}$ leading edge in early write cycles and to $\overline{\text{WE}}$ leading edge in read-modify-write cycles.
- Access time is determined by the longer of t_{AA}, t_{CAC}, or t_{CPA}.
- t_{ASC}≥t_{CP} to achieve t_{PC}(min.) and t_{CPA}(max.) values.
- t_{REF}=128msec for Long Refresh version (L version).

AC ELECTRICAL CHARACTERISTICS (NN5118160B)

Test conditions : $V_{IH}/V_{IL} = 2.4V/0.8V$ $V_{OH}/V_{OL} = 2.4V/0.4V$ output loading $C_L = 100pF + 2TTL$
Operating conditions : (0 °C ≤ T_{as} ≤ 70 °C, V_{CC} = 5.0 V ± 10%, V_{SS} = 0 V) (NOTES 3, 4, 5)

NO.	SYMBOL		PARAMETER	-40		-50		-60		UNIT	NOTE
	JEDEC	STD		MIN.	MAX.	MIN.	MAX.	MIN.	MAX.		
1	t _{CL1QV}	t _{CAC}	Access Time from \overline{CAS}	—	11	—	13	—	15	ns	6,13
2	t _{CH2QV}	t _{CPA}	Access Time from \overline{CAS} Precharge	—	25	—	30	—	35	ns	13,14
3	t _{AVQV}	t _{AA}	Access Time from Column Address	—	20	—	25	—	30	ns	7,13
4	t _{RL1QV}	t _{RAC}	Access Time from \overline{RAS}	—	40	—	50	—	60	ns	6,7
5	t _{RL1CH1}	t _{CSH}	\overline{CAS} Hold Time	40	—	50	—	60	—	ns	
6	t _{RL1CH1}	t _{CHR}	\overline{CAS} Hold Time (\overline{CAS} before \overline{RAS} Refresh)	10	—	10	—	10	—	ns	
7	t _{RL1CX}	t _{CHS}	\overline{CAS} Precharge Time (Self Refresh Mode)	-50	—	-50	—	-50	—	ns	
8	t _{CH2CL2}	t _{CPN}	\overline{CAS} Precharge Time (\overline{CAS} before \overline{RAS} Refresh)	7	—	7	—	10	—	ns	
9	t _{CH2CL2}	t _{CP}	\overline{CAS} Precharge Time (Fast Page Mode)	5	—	5	—	5	—	ns	14
10	t _{CL1CH1}	t _{CAS}	\overline{CAS} Pulse Width	10	100K	15	100K	15	100K	ns	
11	t _{CL1RL2}	t _{CSR}	\overline{CAS} Setup Time (\overline{CAS} before \overline{RAS} Refresh)	5	—	5	—	5	—	ns	
12	t _{CL1QX}	t _{CLZ}	\overline{CAS} to Output in Low-Z	0	—	0	—	0	—	ns	8
13	t _{CH2RL2}	t _{CRP}	\overline{CAS} to \overline{RAS} Precharge Time	5	—	5	—	5	—	ns	
14	t _{CL1WL2}	t _{CWD}	\overline{CAS} to \overline{WE} Delay Time	32	—	32	—	37	—	ns	11
15	t _{CL1AX}	t _{CAH}	Column Address Hold Time	7	—	7	—	10	—	ns	
16	t _{RL1AX}	t _{AR}	Column Address Hold Time Referenced to \overline{RAS}	30	—	35	—	40	—	ns	
17	t _{AVCL2}	t _{ASC}	Column Address Setup Time	0	—	0	—	0	—	ns	14
18	t _{AVRH1}	t _{RAL}	Column Address to \overline{RAS} Lead Time	20	—	25	—	30	—	ns	
19	t _{AVWL2}	t _{AWD}	Column Address to \overline{WE} Delay Time	39	—	39	—	47	—	ns	11
20	t _{CL1DX} t _{WL1DX}	t _{DH}	Data Hold Time	7	—	7	—	10	—	ns	12
21	t _{DVCL2} t _{DVWL2}	t _{DS}	Data Setup Time	0	—	0	—	0	—	ns	12
22	t _{OL1QV}	t _{OEA}	\overline{OE} Access Time	—	11	—	13	—	15	ns	
23	t _{WL1OL2}	t _{OEH}	\overline{OE} Command Hold Time	10	—	13	—	15	—	ns	
24	t _{CH2QV}	t _{OED}	\overline{OE} to Data Delay Time	10	—	15	—	15	—	ns	
25	t _{CH2QZ}	t _{OFF}	Output Buffer Turn-off Delay Time	0	13	0	13	0	15	ns	10
26	t _{CH2QX}	t _{OEZ}	Output Buffer Turn-off Delay Time Referenced to \overline{OE}	0	13	0	13	0	15	ns	
27	t _{CL1RH1}	t _{RSH}	\overline{RAS} Hold Time	10	—	13	—	15	—	ns	
28	t _{OL1RH1}	t _{ROH}	\overline{RAS} Hold Time Referenced to \overline{OE}	10	—	10	—	10	—	ns	
29	t _{RH2RL2}	t _{RP}	\overline{RAS} Precharge Time	25	—	25	—	30	—	ns	
30	t _{RH2RL2}	t _{RPS}	\overline{RAS} Precharge Time (Self Refresh Mode)	72	—	90	—	110	—	ns	
31	t _{RL1RH1}	t _{RAS}	\overline{RAS} Pulse Width	40	100K	50	100K	60	100K	ns	
32	t _{RL1RH1}	t _{RASP}	\overline{RAS} Pulse Width (Fast Page Mode)	40	100K	50	100K	60	100K	ns	
33	t _{RL1RH1}	t _{RASS}	\overline{RAS} Pulse Width (Self Refresh Mode)	300	—	300	—	300	—	μs	
34	t _{RL1CL1}	t _{RCD}	\overline{RAS} to \overline{CAS} Delay Time	10	27	13	35	13	45	ns	6
35	t _{RH2CL2}	t _{RPC}	\overline{RAS} to \overline{CAS} Precharge Time	5	—	5	—	5	—	ns	
36	t _{RL1AV}	t _{RAD}	\overline{RAS} to Column Address Delay Time	9	25	11	25	11	30	ns	7
37	t _{RL1WL2}	t _{RWD}	\overline{RAS} to \overline{WE} Delay Time	60	—	64	—	77	—	ns	11

NN5118160A / NN5118160B series
CMOS 1M × 16bit Dynamic RAM

NO.	SYMBOL		PARAMETER	-40		-50		-60		UNIT	NOTE
	JEDEC	STD		MIN.	MAX.	MIN.	MAX.	MIN.	MAX.		
38	t _{CH2WL2}	t _{RCH}	Read Command Hold Time	0	—	0	—	0	—	ns	9
39	t _{RH2WL2}	t _{RRH}	Read Command Hold Time Referenced to RAS	0	—	0	—	0	—	ns	9
40	t _{WH2CL2}	t _{RCS}	Read Command Setup Time	0	—	0	—	0	—	ns	
41	t _{RL2RL2}	t _{RC}	Random Read or Write Cycle Time	80	—	90	—	110	—	ns	
42	t _{CL2CL2}	t _{PC}	Read or Write Cycle Time (Fast Page Mode)	30	—	35	—	40	—	ns	13,14
43	t _{RL2RL2}	t _{RMW}	Read-Modify-Write Cycle Time	110	—	120	—	140	—	ns	
44	t _{CL2CL2}	t _{PRMW}	Read-Modify-Write Cycle Time (Fast Page Mode)	75	—	80	—	85	—	ns	13,14
45	t _{REF}	t _{REF}	Refresh Period	—	16	—	16	—	16	ms	
46	t _{RL1AX}	t _{RAH}	Row Address Hold Time	6	—	8	—	8	—	ns	
47	t _{AVRL2}	t _{ASR}	Row Address Setup Time	0	—	0	—	0	—	ns	
48	t _T	t _T	Transition Time (Rise and Fall)	1	50	1	50	1	50	ns	4,5
49	t _{CL1WH1}	t _{WCH}	Write Command Hold Time	7	—	10	—	10	—	ns	
50	t _{WL1WH1}	t _{WP}	Write Command Pulse Width	7	—	10	—	10	—	ns	
51	t _{WL1CL2}	t _{WCS}	Write Command Setup Time	0	—	0	—	0	—	ns	11
52	t _{WL1CH1}	t _{CWL}	Write Command to $\overline{\text{CAS}}$ Lead Time	7	—	7	—	10	—	ns	
53	t _{WL1RH1}	t _{RWL}	Write Command to $\overline{\text{RAS}}$ Lead Time	7	—	7	—	10	—	ns	
54	t _{WH2RL2}	t _{WRP}	$\overline{\text{WE}}$ to $\overline{\text{RAS}}$ Precharge Time	10	—	10	—	10	—	ns	
55	t _{RL1WH2}	t _{WRH}	$\overline{\text{WE}}$ to $\overline{\text{RAS}}$ Hold Time	10	—	10	—	10	—	ns	

Notes:

- Eight Initialization Cycles are required following a 200 μ s pause after Power Up. These Initialization Cycles may consist of one of the following : $\overline{\text{RAS}}$ only refresh Cycles, Read Cycles, Write Cycles, $\overline{\text{CAS}}$ before $\overline{\text{RAS}}$ refresh Cycles.
- AC measurements assume $t_T=2$ ns.
- $V_{IH}(\text{min.})$ and $V_{IL}(\text{max.})$ are reference levels for measuring timing of input signals. Also, transition times are measured between V_{IH} and V_{IL} .
- Operation within the $t_{RCD}(\text{max.})$ limit ensures that $t_{RAC}(\text{max.})$ can be met. $t_{RCD}(\text{max.})$ is specified as a reference point only. If t_{RCD} is greater than the specified $t_{RCD}(\text{max.})$ limit, then access time is controlled by t_{CAC} .
- Operation within the $t_{RAD}(\text{max.})$ limit ensures that $t_{RAC}(\text{max.})$ can be met. $t_{RAD}(\text{max.})$ is specified as a reference point only. If t_{RAD} is greater than the specified $t_{RAD}(\text{max.})$ limit, then access time is controlled by t_{AA} .
- Assumes three state test load (5pF and a 220 ohm to 1.3V Thevenin equivalent).
- Either t_{RCH} or t_{RRH} must be satisfied for a read cycle.
- $t_{OFF}(\text{max.})$ defines the time at which the output achieves an open circuit condition and is not referenced to output voltage levels.
- t_{WCS} , t_{RWD} , t_{CWD} and t_{AWD} are not restrictive operating parameters. They are included in the data sheet as electrical characteristics only. If $t_{WCS} \geq t_{WCS}(\text{min.})$, the cycle is an early write cycle and data-out pins will remain open circuit (high impedance) throughout the entire cycle. If $t_{RWD} \geq t_{RWD}(\text{min.})$, $t_{CWD} \geq t_{CWD}(\text{min.})$ and $t_{AWD} \geq t_{AWD}(\text{min.})$, the cycle is a read-modify-write cycle and the data-out will contain data read from the selected cell. If neither of the above conditions is satisfied, the condition of the data-out (at access time) is indeterminate.
- These parameters are referenced to $\overline{\text{CAS}}$ leading edge in early write cycles and to $\overline{\text{WE}}$ leading edge in read-modify-write cycles.
- Access time is determined by the longer of t_{AA} , t_{CAC} , or t_{CPA} .
- $t_{ASC} \geq t_{CP}$ to achieve $t_{PC}(\text{min.})$ and $t_{CPA}(\text{max.})$ values.
- $t_{REF}=128$ msec for Long Refresh version (L version).

9005650 0000949 886

WORD READ CYCLE

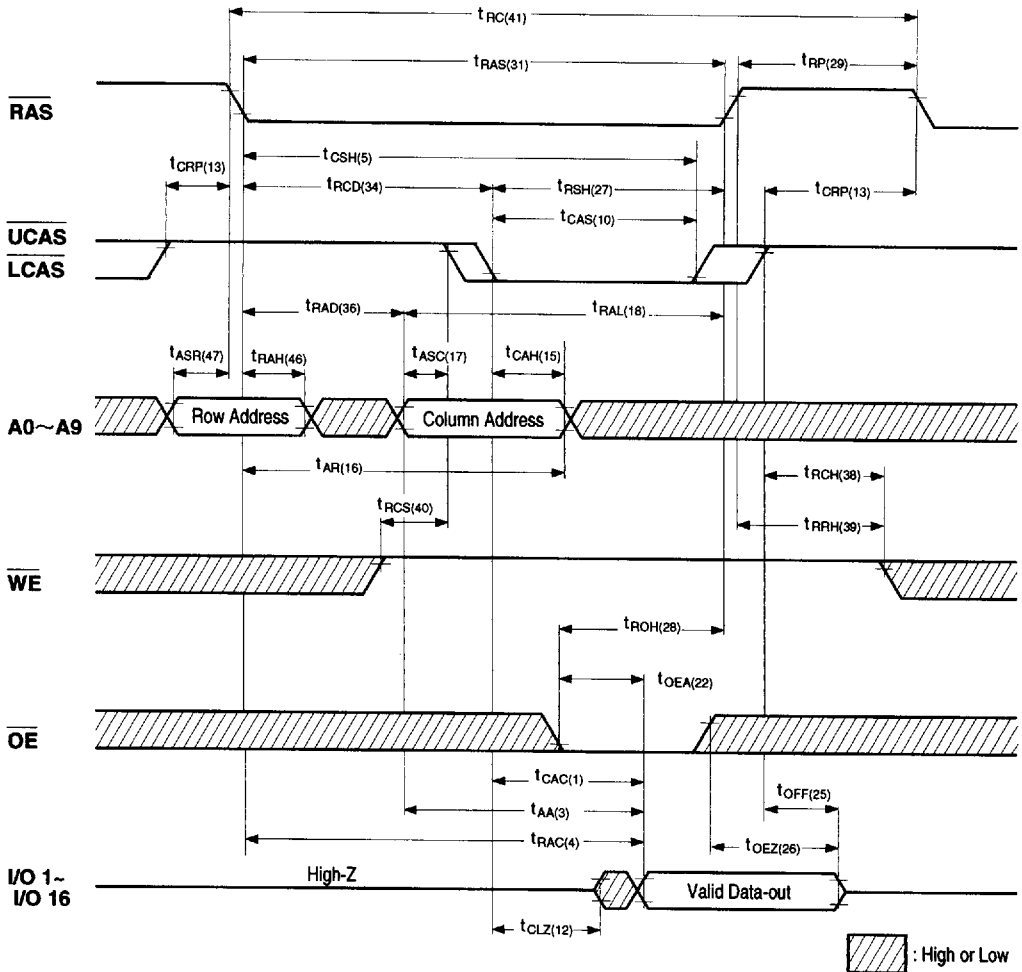

BYTE READ CYCLE

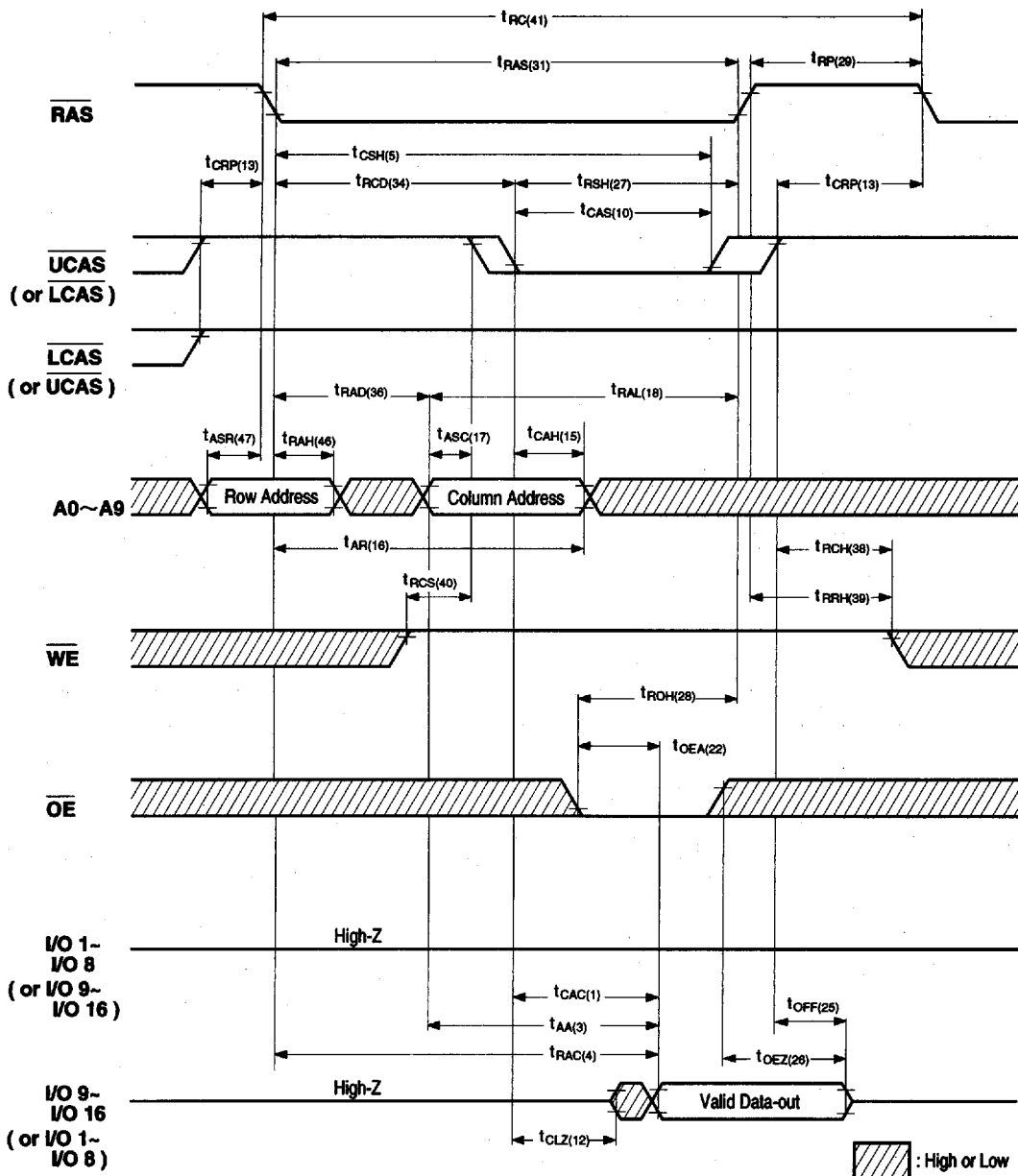

WORD WRITE CYCLE (EARLY WRITE)

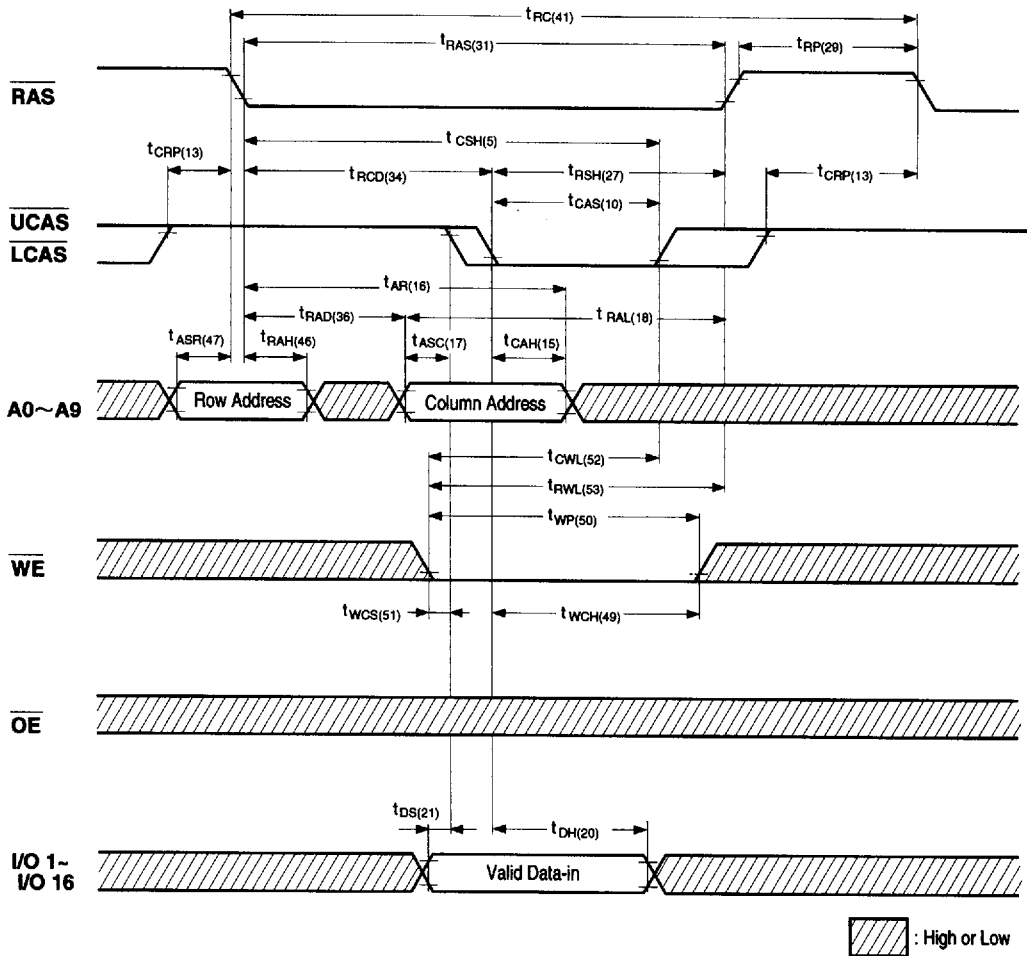

BYTE WRITE CYCLE (EARLY WRITE)

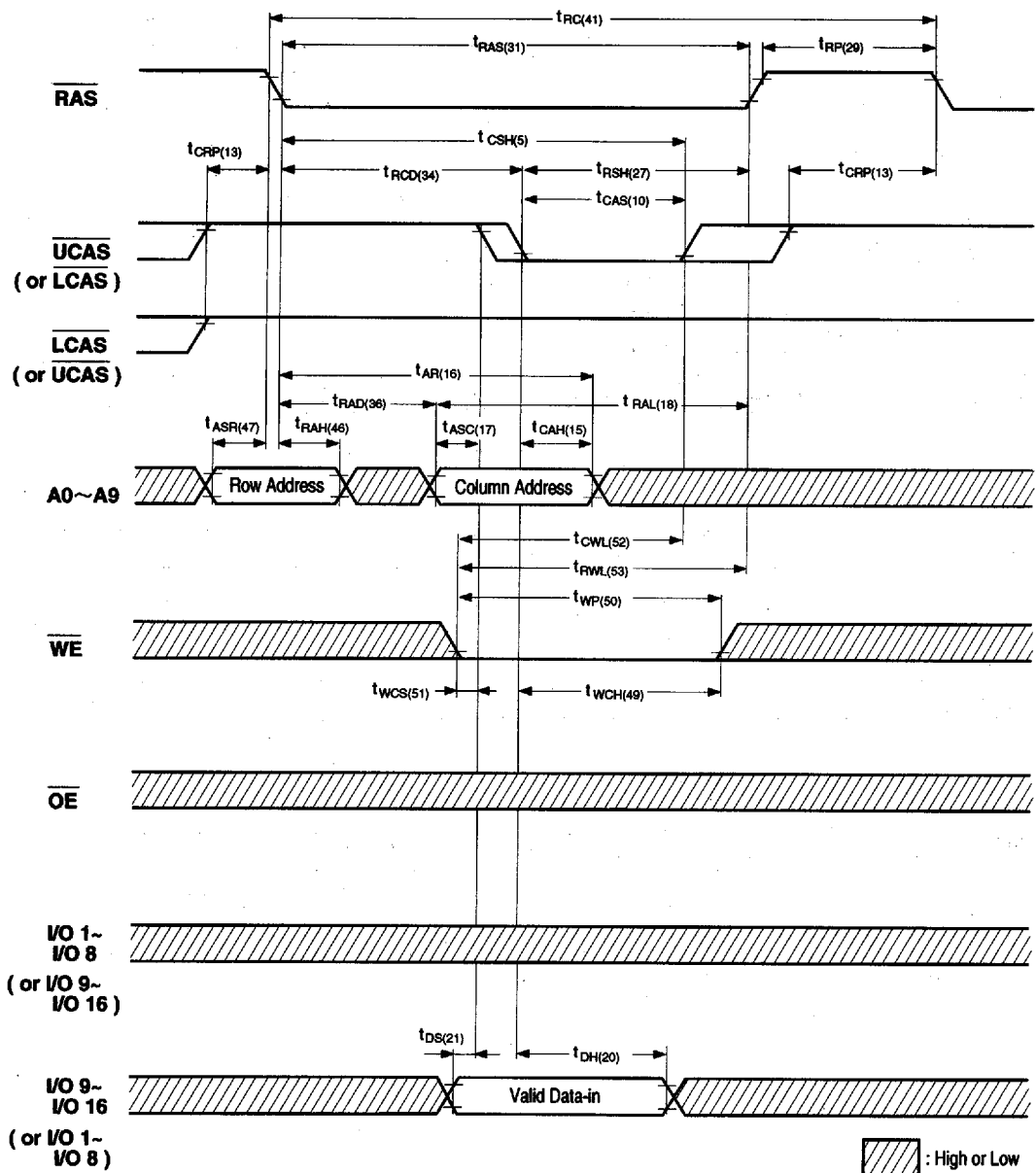

9005650 0000953 207

WORD WRITE CYCLE (\overline{OE} -CONTROLLED WRITE)

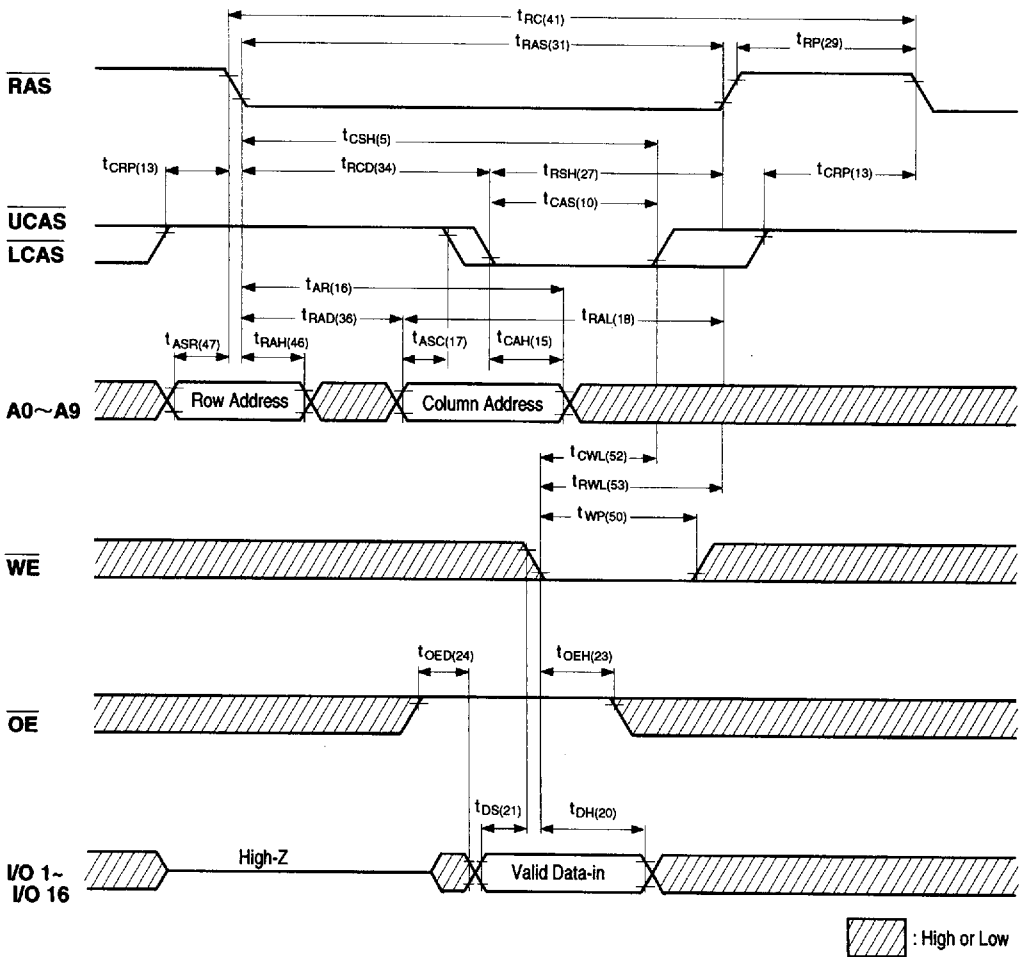

BYTE WRITE CYCLE ($\overline{\text{OE}}$ -CONTROLLED WRITE)

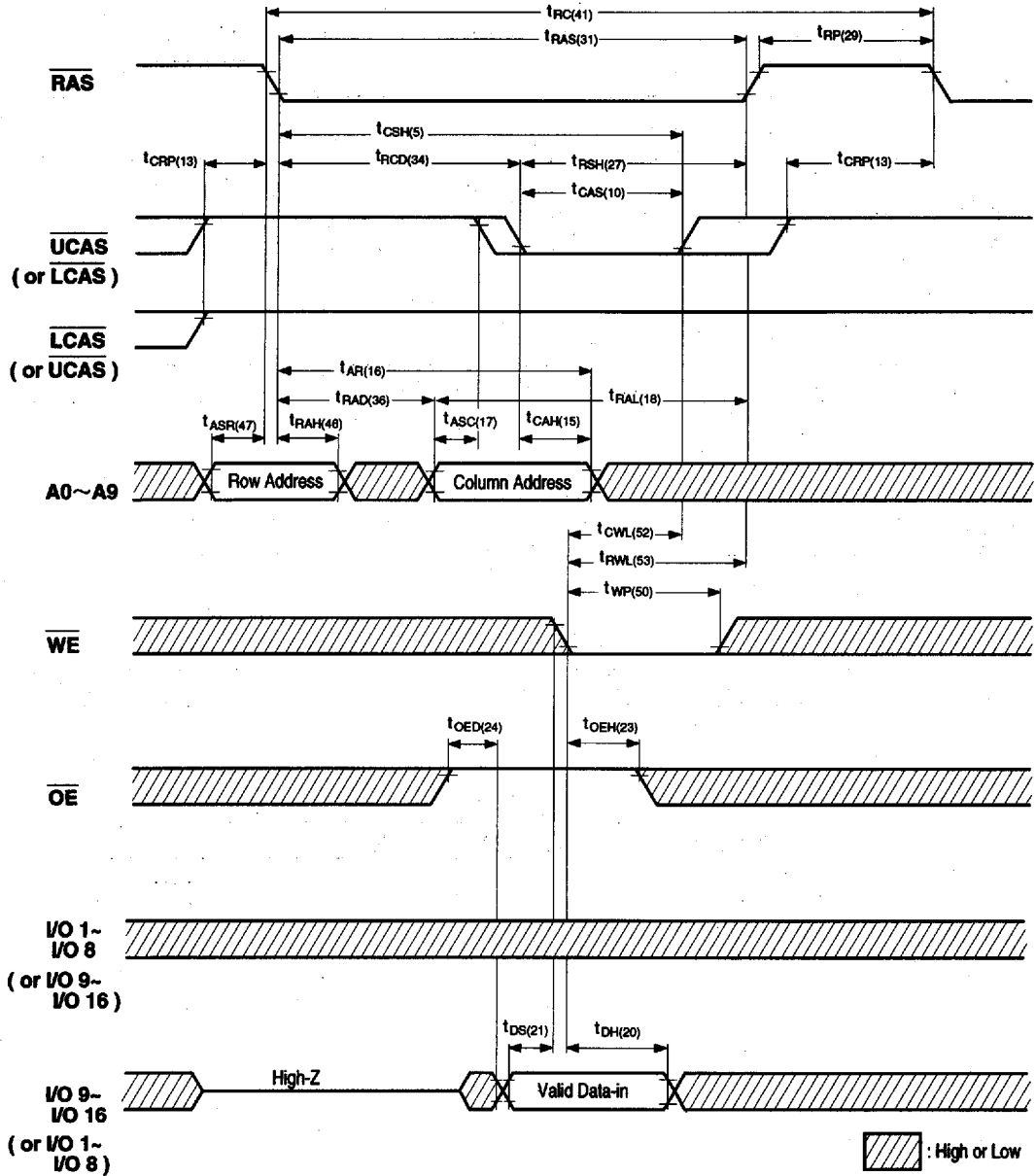

WORD READ-MODIFY-WRITE CYCLE

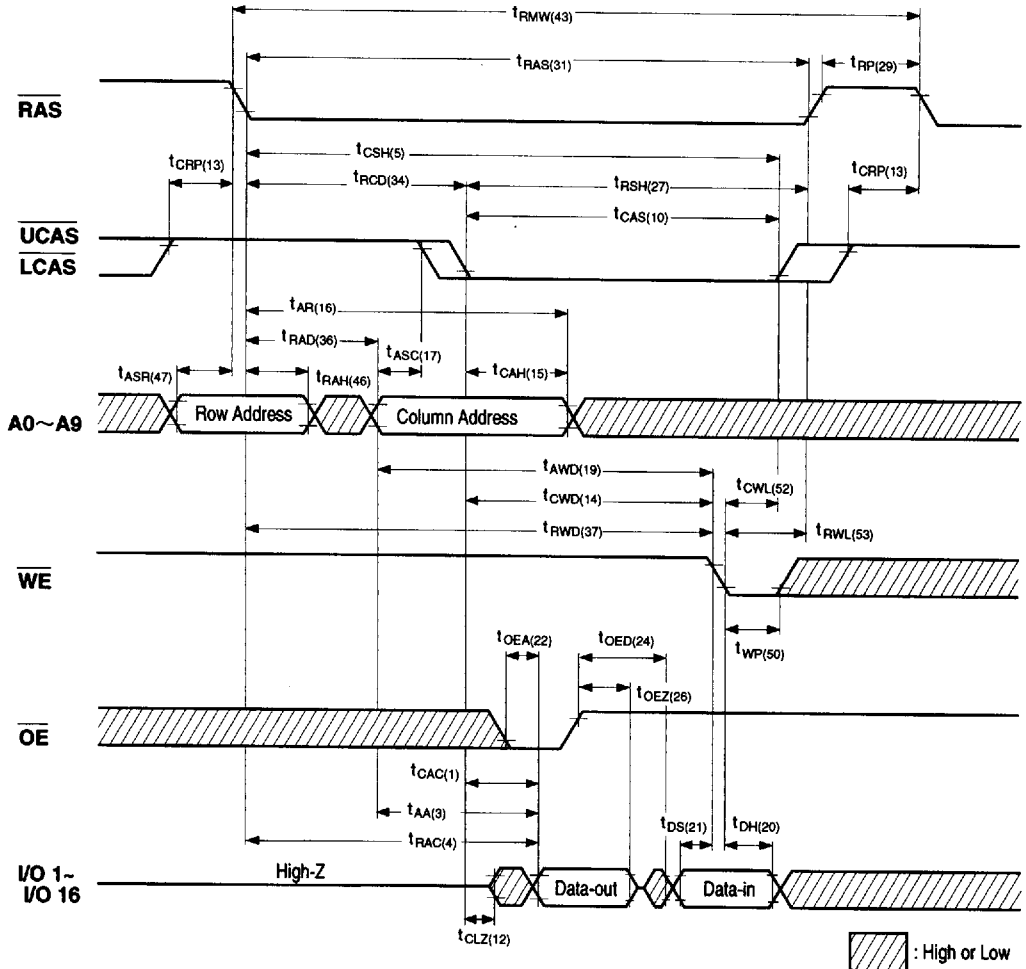

BYTE READ-MODIFY-WRITE CYCLE

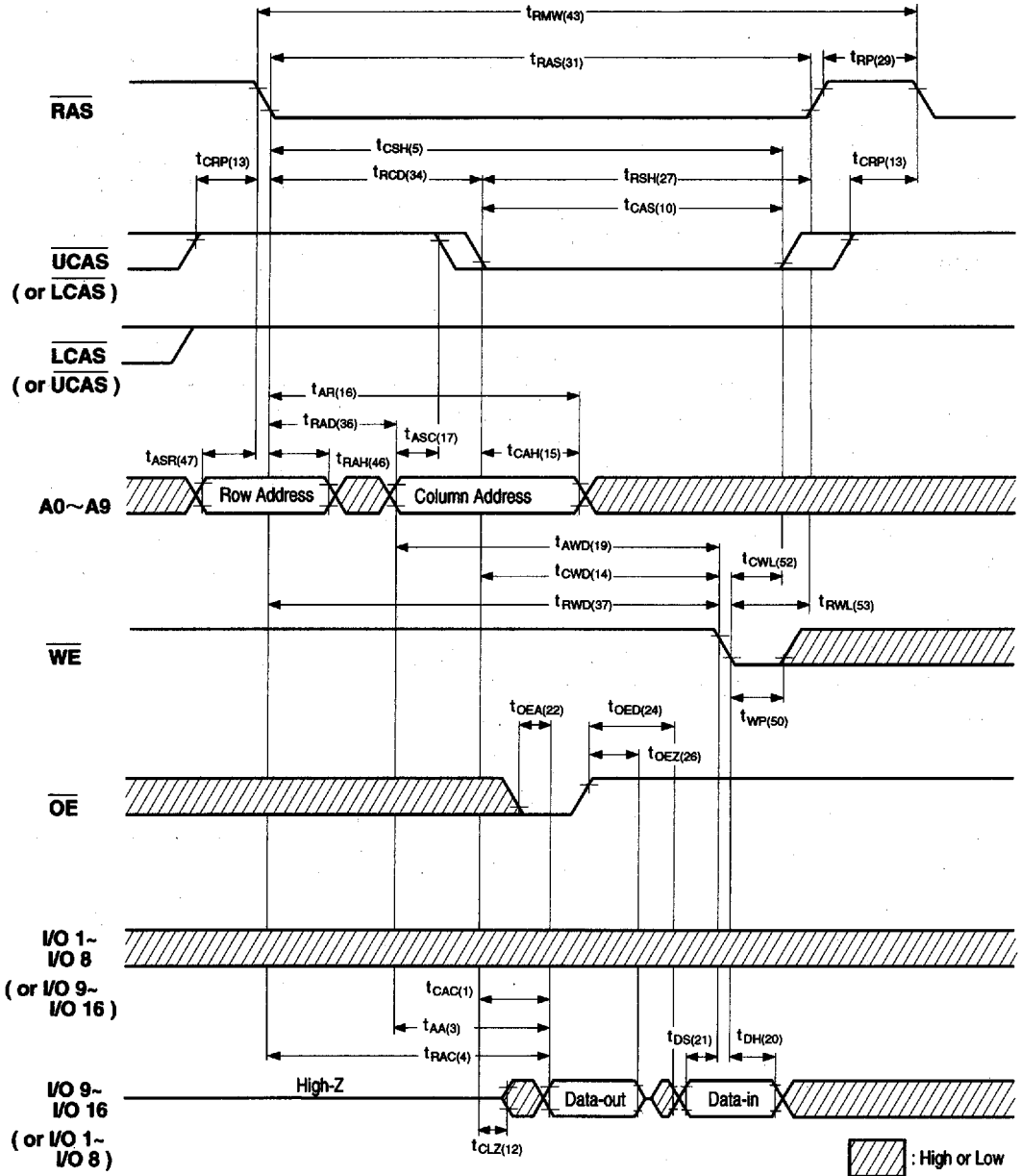

9005650 0000957 952

FAST PAGE MODE BYTE READ CYCLE

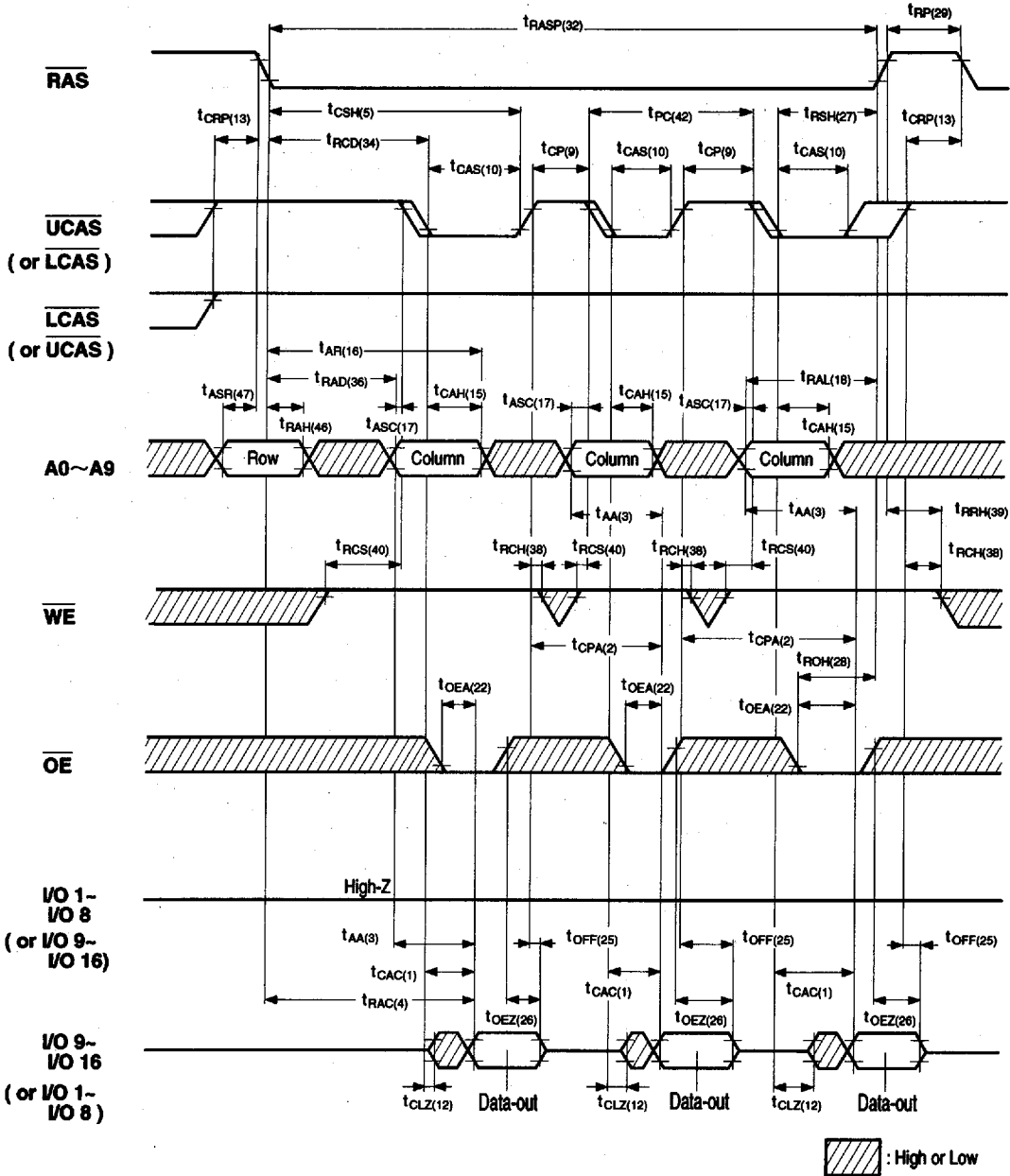

9005650 0000959 725

FAST PAGE MODE EARLY WORD WRITE CYCLE

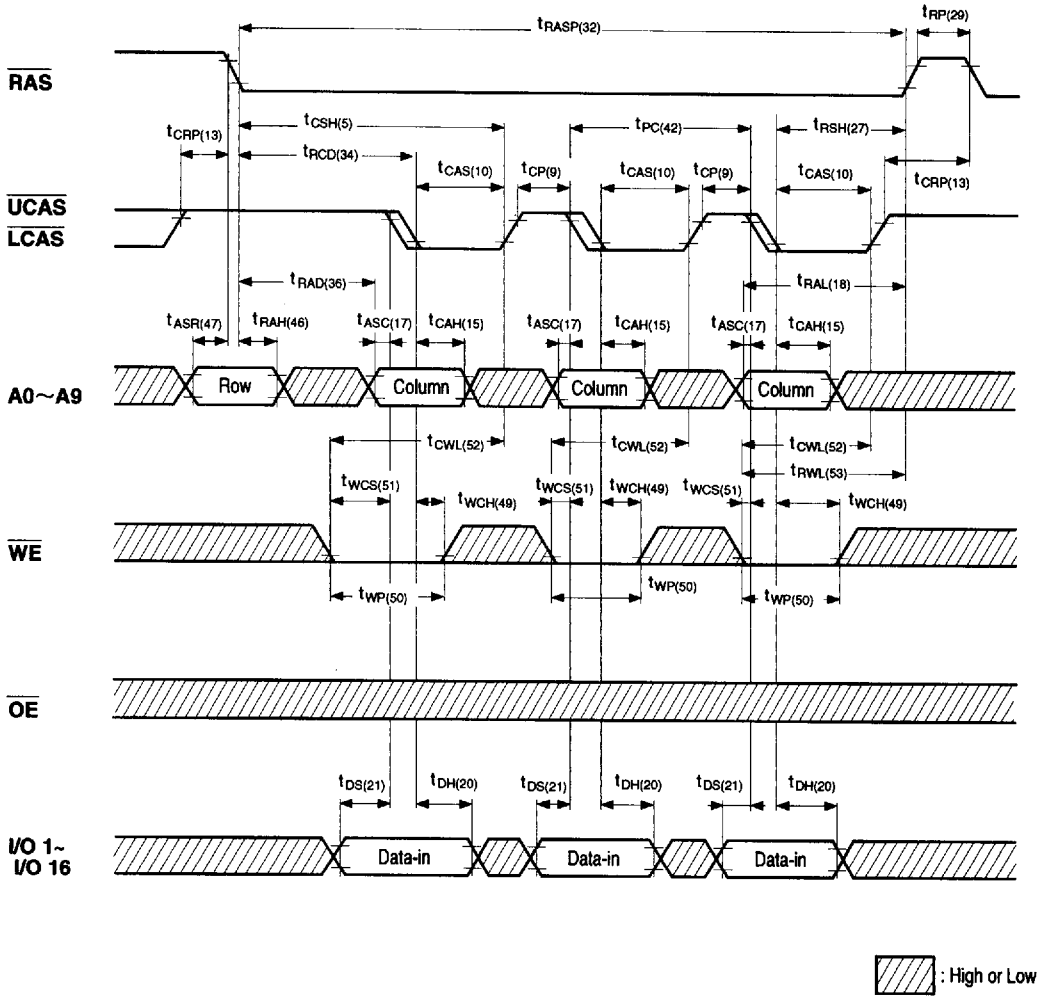

FAST PAGE MODE EARLY BYTE WRITE CYCLE

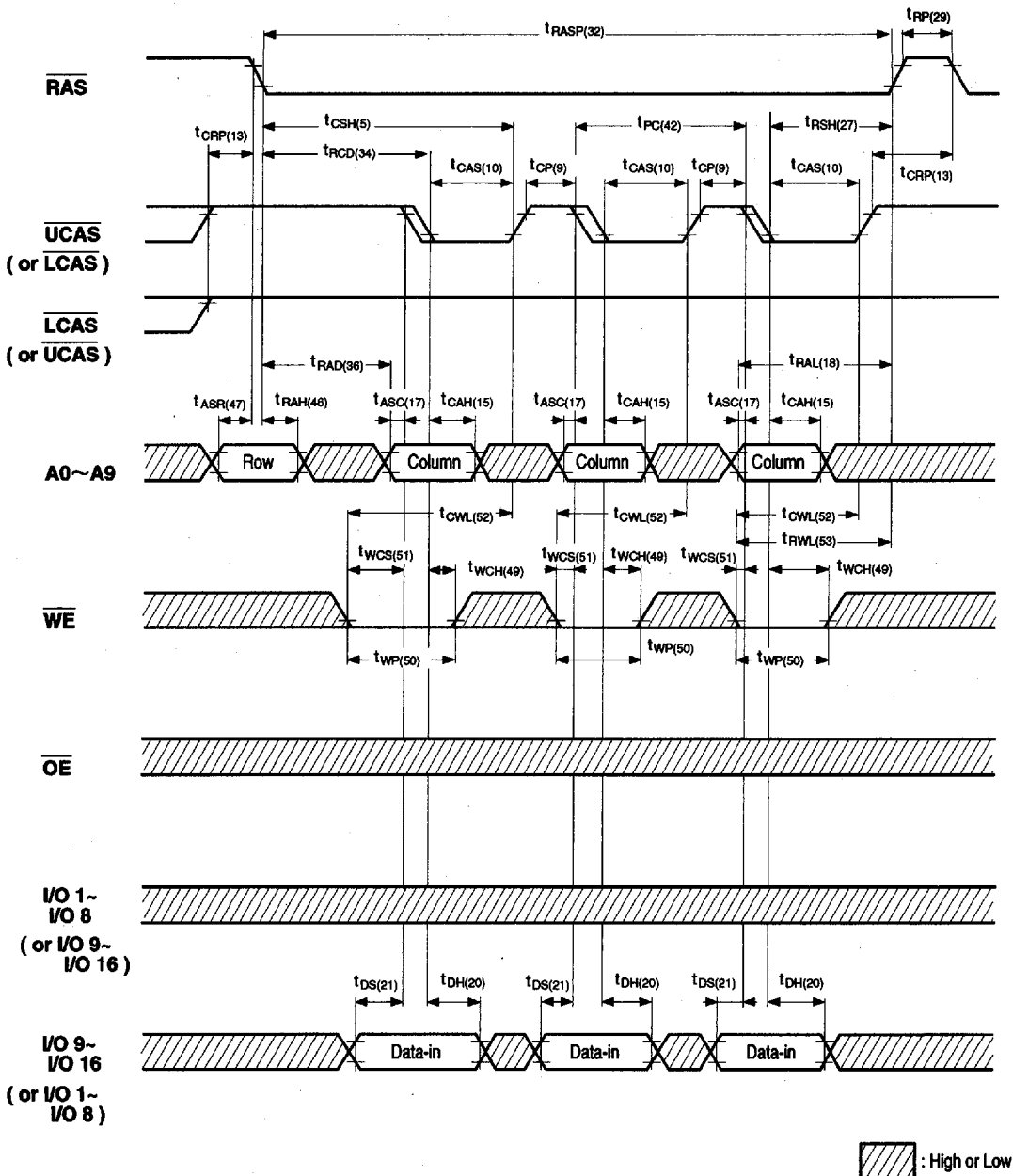

RAS ONLY REFRESH CYCLE

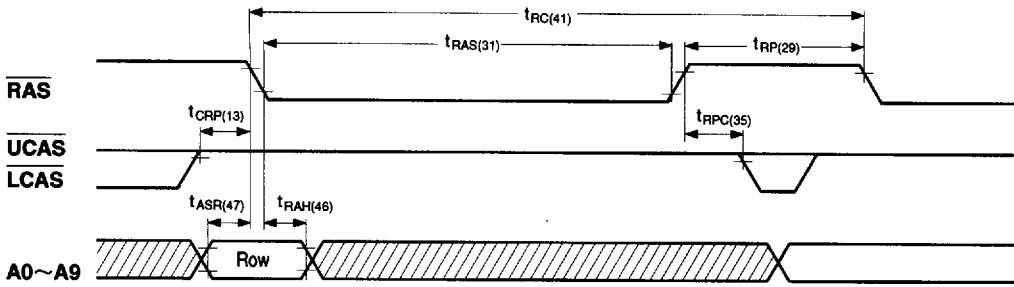

NOTE : \overline{WE} , \overline{OE} = Don't care.

 : High or Low

CAS BEFORE RAS REFRESH CYCLE

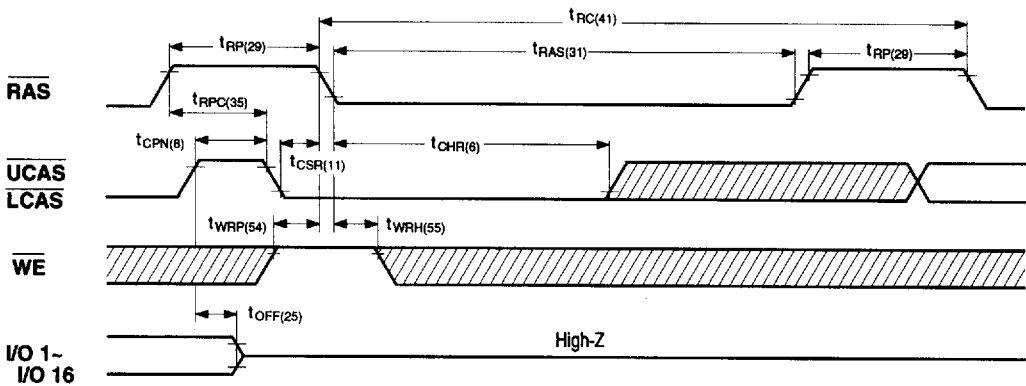

Note: \overline{OE} , A0~A9 = Don't care.

 : High or Low

HIDDEN REFRESH CYCLE (WORD READ)

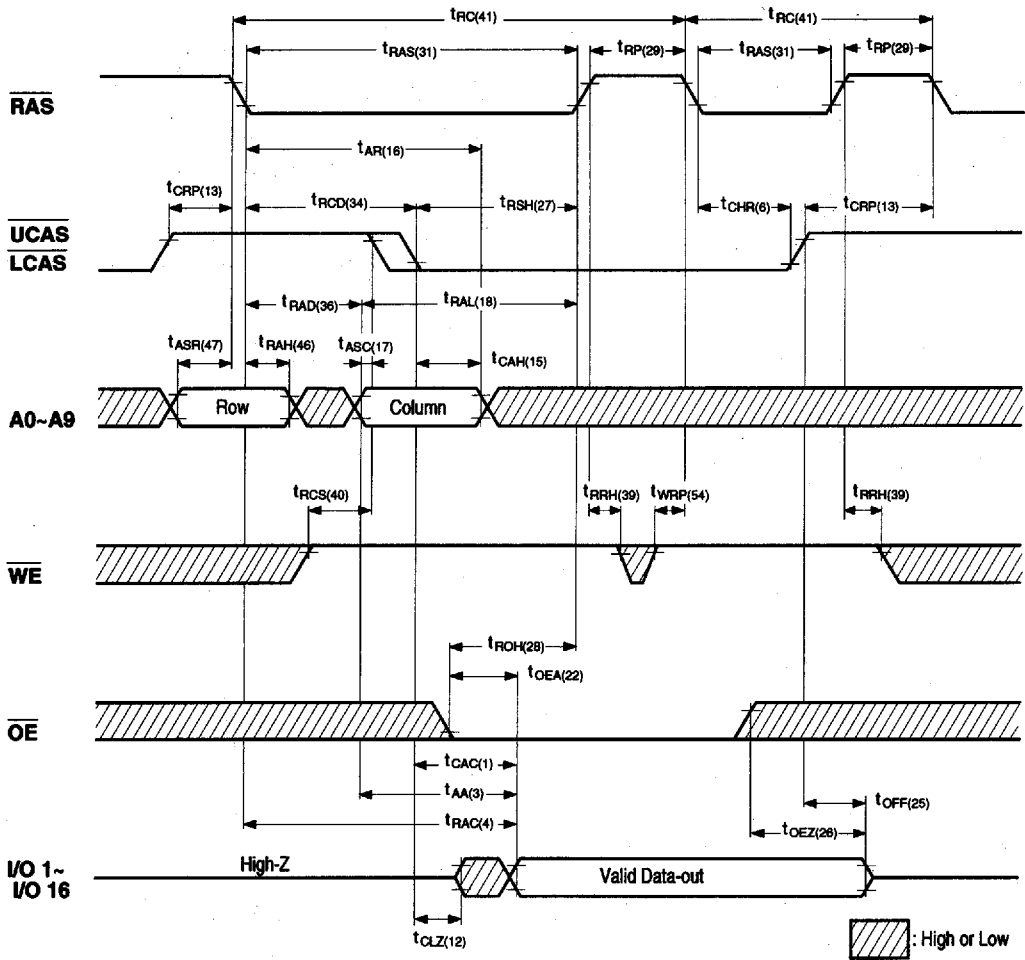

9005650 0000965 T29

HIDDEN REFRESH CYCLE (BYTE READ)

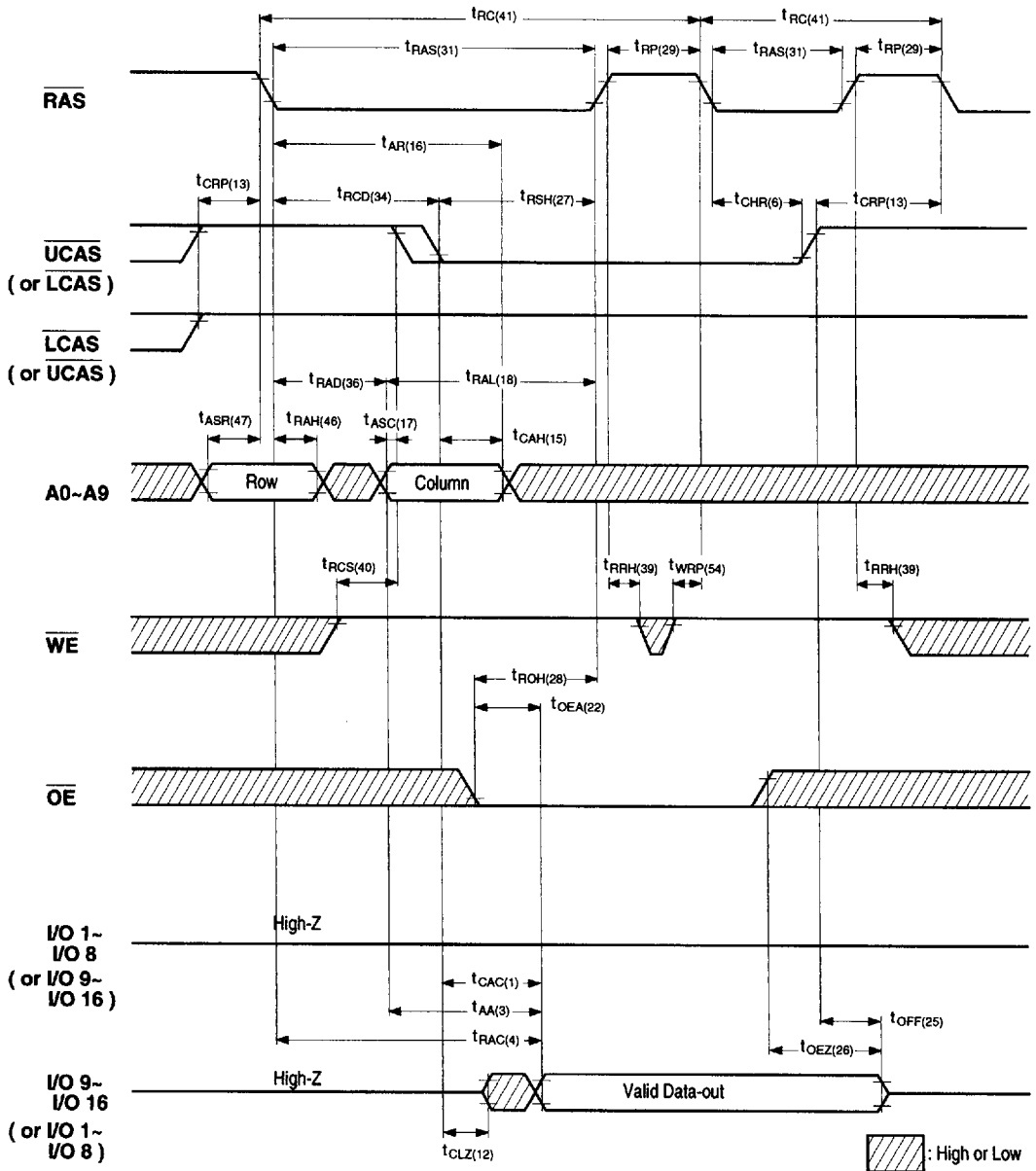

HIDDEN REFRESH CYCLE (EARLY WORD WRITE)

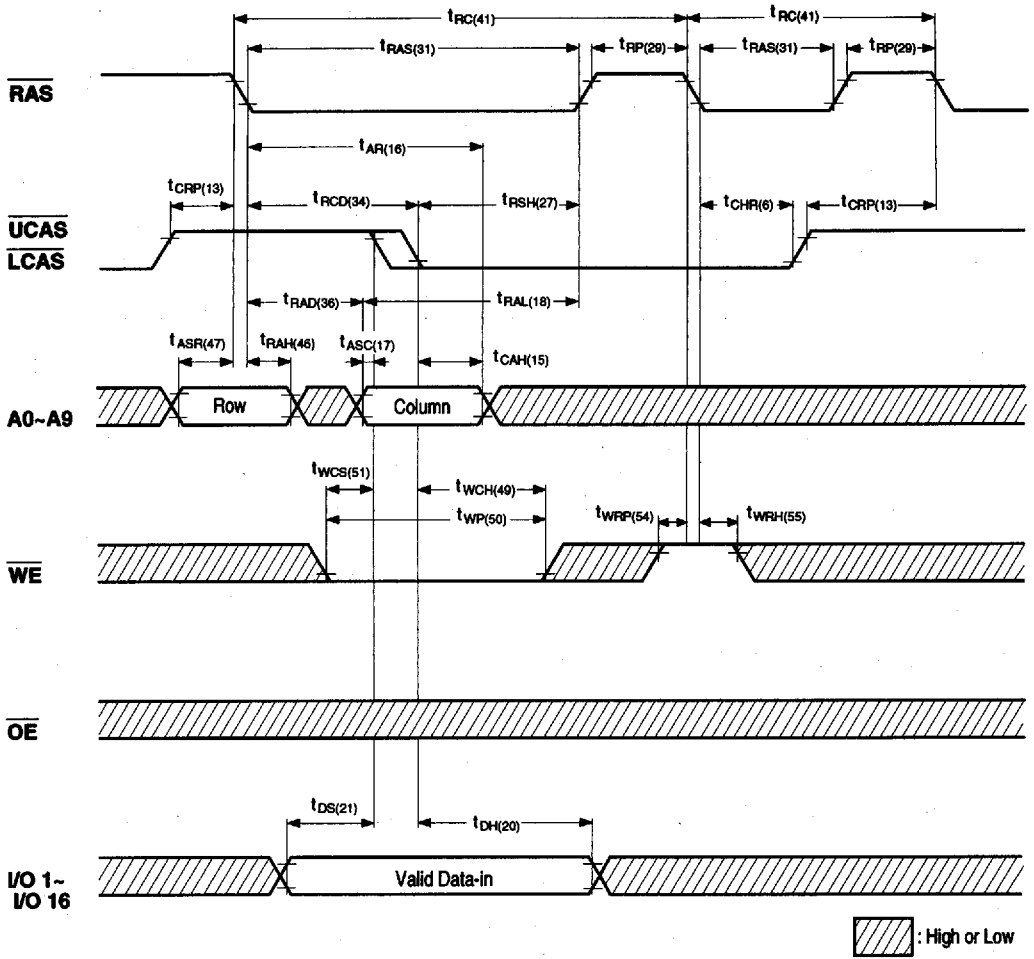

HIDDEN REFRESH CYCLE (EARLY BYTE WRITE)

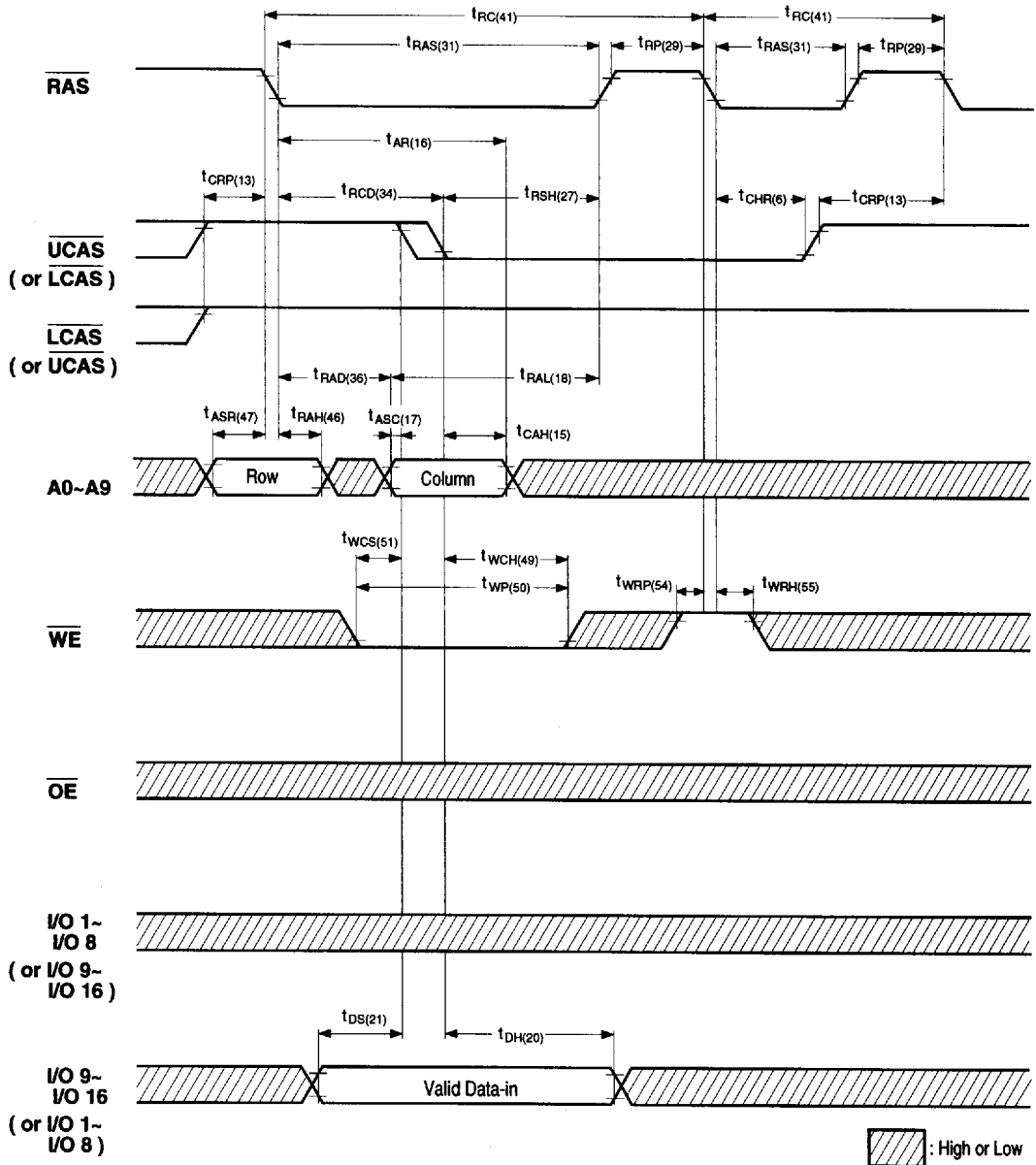

SELF REFRESH MODE

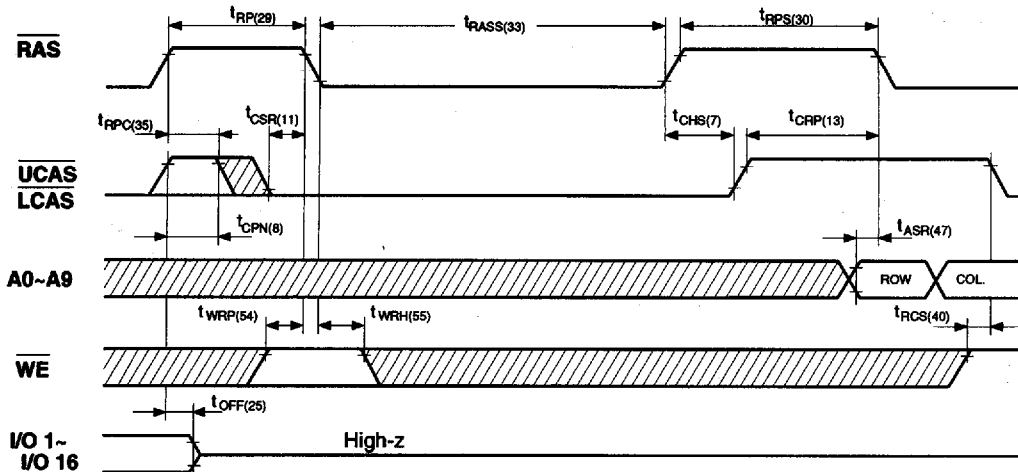

■ The NN5118160A / NN5118160B (L version) has a Self Refresh Mode.

a. Entering the Self Refresh Mode:

The NN5118160AL / NN5118160BL Self Refresh Mode is entered by using $\overline{\text{CAS}}$ before $\overline{\text{RAS}}$ cycle and holding $\overline{\text{RAS}}$ and $\overline{\text{CAS}}$ signal " low " longer than 300 μ s.

b. Continuing the Self Refresh Mode:

The Self Refresh Mode is continuing by holding $\overline{\text{RAS}}$ " low " after entering the Self Refresh Mode. It does not depend on $\overline{\text{CAS}}$ being " high " or " low " after entering the Self Refresh Mode to continue the Self Refresh Mode.

c. Exiting the Self Refresh Mode:

The NN5118160AL / NN5118160BL exits will exit the Self Refresh Mode when the $\overline{\text{RAS}}$ signal is brought " high ".

ORDERING INFORMATION

NN5118160AXX(X) - XX

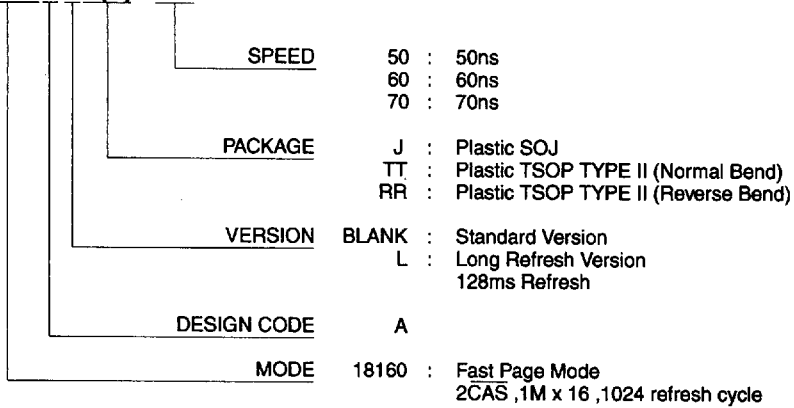

NN5118160BXX(X) - XX

