

SP9T ANTENNA SWITCH GaAs MMIC

■ GENERAL DESCRIPTION

The NJG1672LK4 is a GaAs SP9T antenna switch IC for GSM/TD-SCDMA multi-band handsets. The IC contains a MMIC switch die with on-chip logic circuits and a LTCC substrate with built-in three LPFs on GSM/TD-SCDMA transmit paths for suppression of transmitter harmonics.

This switch IC features very low harmonics, low insertion loss, high Isolation and small package size.

This IC has ESD protection devices to achieve excellent ESD performance.

No DC Blocking capacitors are required for RF ports.

■ PACKAGE OUTLINE

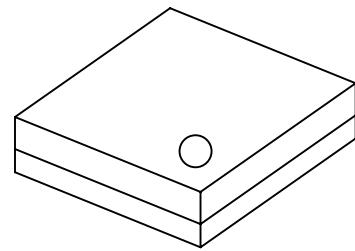

NJG1672LK4

■ FEATURES

- Built-in three LPFs Attenuation 35/32/30 dB typ. on GSM850/900 TX @2fo / 3fo / 4fo
 Attenuation 32/45 dB typ. on GSM1800/1900 TX @2fo / 3fo
 Attenuation 35 dB typ. on LCR TX @2fo / 3fo
- Low harmonics -78/-75dBc typ. on GSM850/900 TX @2fo / 3fo, Pin=+35dBm, V_{DD}=2.7V
 -85dBc typ. on GSM1800/1900 TX @2fo / 3fo, Pin=+32dBm, V_{DD}=2.7V
 -90/-95dBc typ. on LCR TX @2fo / 3fo, Pin=+26dBm, V_{DD}=2.7V
- Low insertion loss 1.0dB typ. on GSM850/900 TX @f=915MHz, Pin=35dBm, V_{DD}=2.7V
 0.9dB typ. on GSM1800/1900 TX @f=1910MHz, Pin=32dBm, V_{DD}=2.7V
 1.0dB typ. on LCR TX @f=2025MHz, Pin=26dBm, V_{DD}=2.7V
- Small package size LCSP24-K4 (Package size: 3.8x3.8x0.9mm typ.)

■ PIN CONFIGURATION

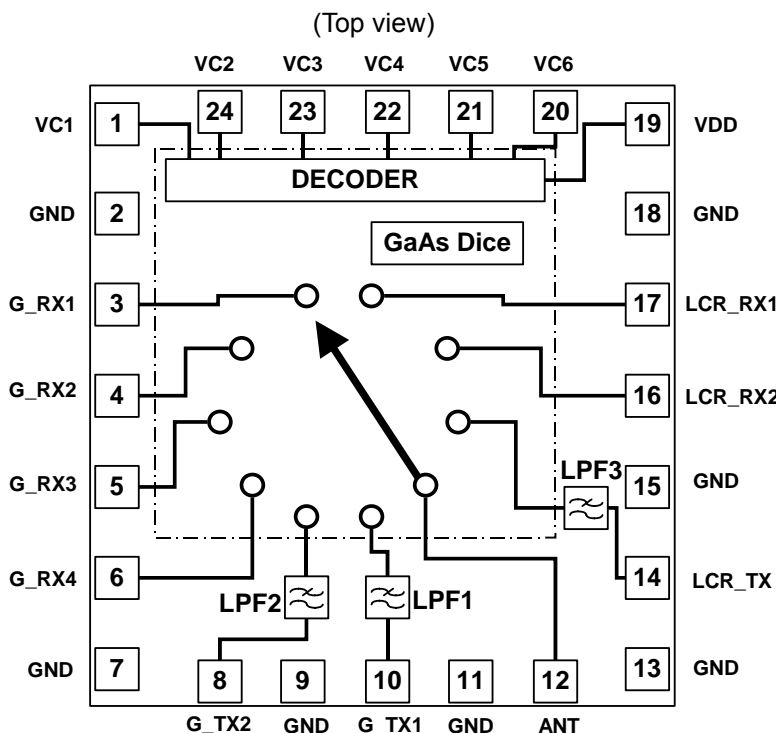

PIN CONNECTION

1. VC1
2. GND
3. G_RX1(GSM850 RX)
4. G_RX2(GSM900 RX)
5. G_RX3(GSM1800 RX)
6. G_RX4(GSM1900 RX)
7. GND
8. G_TX2(GSM1800/1900 TX)
9. GND
10. G_TX1(GSM850/900 TX)
11. GND
12. ANT
13. GND
14. LCR_TX(LCR 1.9G/2.0G TX)
15. GND
16. LCR_RX2(LCR 2.0G RX)
17. LCR_RX1(LCR 1.9G RX)
18. GND
19. VDD
20. VC6
21. VC5
22. VC4
23. VC3
24. VC2

NJG1672LK4

■ TRUTH TABLE

"H" = $V_{CTL(H)}$, "L" = $V_{CTL(L)}$

On Path	VC1	VC2	VC3	VC4	VC5	VC6
ANT - G_RX1	H	H	L	L	L	L
ANT - G_RX2	L	H	L	L	L	L
ANT - G_RX3	H	L	L	L	L	L
ANT - G_RX4	L	L	L	L	L	L
G_TX1 - ANT	L	H	H	L	L	L
G_TX2 - ANT	L	L	H	L	L	L
LCR_TX - ANT	L	L	L	H	L	L/H
ANT - LCR_RX2	L	L	L	L	H	L
ANT - LCR_RX1	L	L	L	L	H	H

NOTE: Please note that any data or drawing in this catalog is subject to change.

■ ABSOLUTE MAXIMUM RATINGS

(General conditions: $T_a=+25^{\circ}\text{C}$, $Z_s=Z_l=50\Omega$, $V_{DD}=2.7\text{V}$, $V_{CTL(L)}=0\text{V}$, $V_{CTL(H)}=1.8\text{V}$)

PARAMETER	SYMBOL	CONDITIONS		DUTY CYCLE	RATINGS	UNITS		
RF Input Power	TX Pin	G_TX1 - ANT	824MHz~849MHz	4 : 8	36	dBm		
			880MHz~915MHz					
		G_TX2 - ANT	1710MHz~1785MHz					
			1850MHz~1910MHz					
		LCR_TX - ANT	1880MHz~1920MHz				34	dBm
			2010MHz~2025MHz					
	RX Pin	G_RX1 - ANT	869MHz~894MHz	CW	28	dBm		
			G_RX2 - ANT				925MHz~960MHz	
			G_RX3 - ANT				1805MHz~1880MHz	
			G_RX4 - ANT				1930MHz~1990MHz	
			LCR_RX1 - ANT				1880MHz~1920MHz	
			LCR_RX2 - ANT				2010MHz~2025MHz	
	ANT Pin	ANT - G_TX1	824MHz~849MHz	4 : 8	36	dBm		
			880MHz~915MHz					
			ANT - G_TX2				1710MHz~1785MHz	
			1850MHz~1910MHz					
ANT - LCR_TX		1880MHz~1920MHz	34	dBm				
		2010MHz~2025MHz						
ANT - G_RX1		869MHz~894MHz	CW	28	dBm			
		ANT - G_RX2				925MHz~960MHz		
		ANT - G_RX3				1805MHz~1880MHz		
		ANT - G_RX4				1930MHz~1990MHz		
	ANT - LCR_RX1	1880MHz~1920MHz						
	ANT - LCR_RX2	2010MHz~2025MHz						
Supply Voltage	V_{DD}	VDD terminal			3.2	V		
Control Voltage	V_{CTL}	VC1~6 terminal			5	V		
Power Dissipation	P_D				1200	mW		
Operating Temperature	T_{opr}				-40~+85	$^{\circ}\text{C}$		
Storage Temperature	T_{stg}				-40~+150	$^{\circ}\text{C}$		

NJG1672LK4

■ ELECTRICAL CHARACTERISTICS 1 (DC)

(General conditions: $T_a=+25^{\circ}\text{C}$, $Z_s=Z_l=50\Omega$, $V_{DD}=2.7\text{V}$, $V_{CTL(L)}=0\text{V}$, $V_{CTL(H)}=1.8\text{V}$)

PARAMETER	SYMBOL	CONDITIONS	MIN	TYP	MAX	UNITS
Supply Voltage	V_{DD}	VDD terminal	2.6	2.7	3.1	V
Operating Current 1	I_{DD1}	VDD terminal, $f_{in}=824\sim 915\text{MHz}$ GSM850/900 TX, $P_{in}=35\text{dBm}$	-	500	1000	μA
Operating Current 2	I_{DD2}	VDD terminal, Sleep mode	-	-	0	μA
Control Current	I_{CTL}	$V_{CTL(H)}=1.8\text{V}/1\text{Port}$	-	4	10	μA
Control Voltage	$V_{CTL(H)}$		1.3	1.8	3	V
	$V_{CTL(L)}$		-0.2	0	0.2	V

■ ELECTRICAL CHARACTERISTICS 2 (G_TX1: GSM850/900 TX ON mode)

(General conditions: $T_a=+25^{\circ}\text{C}$, $Z_s=Z_l=50\Omega$, $V_{DD}=2.7\text{V}$, $V_{CTL(L)}=0\text{V}$, $V_{CTL(H)}=1.8\text{V}$)

PARAMETER	SYMBOL	CONDITIONS	NJRC Target SPEC.			UNITS
			MIN	TYP	MAX	
Frequency Range 1	$f_{\text{GSM850 TX}}$	GSM850 TX Band	824	-	849	MHz
Frequency Range 2	$f_{\text{GSM900 TX}}$	GSM900 TX Band	880	-	915	MHz
Insertion Loss 1(1)	LOSS1(1)	G_TX1 - ANT, $f_{\text{GSM850 TX}}$, $f_{\text{GSM900 TX}}$ Pin=35dBm	-	1.0	1.3	dB
Insertion Loss 1(2)	LOSS1(2)	G_TX1 - ANT, $f_{\text{GSM850 TX}}$, $f_{\text{GSM900 TX}}$ Pin=35dBm ($T_a=-25^{\circ}\text{C}\sim+75^{\circ}\text{C}$)	-	-	1.3	dB
Isolation 1(1)	ISL1(1)	G_TX1 to G_RX1, $f_{\text{GSM850 TX}}$, $f_{\text{GSM900 TX}}$ Pin=35dBm	35	45	-	dB
Isolation 1(2)	ISL1(2)	G_TX1 to G_RX2, $f_{\text{GSM850 TX}}$, $f_{\text{GSM900 TX}}$,Pin=35dBm	35	45	-	dB
Isolation 1(3)	ISL1(3)	G_TX1 to G_RX3, $f_{\text{GSM850 TX}}$, $f_{\text{GSM900 TX}}$, Pin=35dBm	35	45	-	dB
Isolation 1(4)	ISL1(4)	G_TX1 to G_RX4, $f_{\text{GSM850 TX}}$, $f_{\text{GSM900 TX}}$,Pin=35dBm	35	45	-	dB
Isolation 1(5)	ISL1(5)	G_TX1 to LCR_RX1, $f_{\text{GSM850 TX}}$, $f_{\text{GSM900 TX}}$,Pin=35dBm	35	45	-	dB
Isolation 1(6)	ISL1(6)	G_TX1 to LCR_RX2, $f_{\text{GSM850 TX}}$, $f_{\text{GSM900 TX}}$,Pin=35dBm	30	37	-	dB
VSWR 1(1)	VSWR1(1)	ANT port, $f_{\text{GSM850 TX}}$, $f_{\text{GSM900 TX}}$	-	1.2	1.5	
VSWR 1(2)	VSWR1(2)	G_TX1 port, $f_{\text{GSM850 TX}}$, $f_{\text{GSM900 TX}}$	-	1.2	1.5	
2nd Harmonic Suppression 1	2HS(1)	G_TX1 to ANT, $2x f_{\text{GSM850 TX}}$, $2x f_{\text{GSM900 TX}}$	25	35	-	dB
3rd Harmonic Suppression 1	3HS(1)	G_TX1 to ANT, $3x f_{\text{GSM850 TX}}$, $3x f_{\text{GSM900 TX}}$	25	32	-	dB
4th Harmonic Suppression 1	4HS(1)	G_TX1 to ANT, $4x f_{\text{GSM850 TX}}$, $3x f_{\text{GSM900 TX}}$	20	30	-	dB
2nd Harmonics 1	$2f_o(1)$	G_TX1 to ANT, $f_o= f_{\text{GSM850 TX}}$, $f_{\text{GSM900 TX}}$, Pin=35dBm	-	-78	-72	dBc
3rd Harmonics 1	$3f_o(1)$	G_TX1 to ANT, $f_o= f_{\text{GSM850 TX}}$, $f_{\text{GSM900 TX}}$, Pin=35dBm	-	-75	-70	dBc
4th Harmonics 1	$4f_o(1)$	G_TX1 to ANT, $f_o= f_{\text{GSM850 TX}}$, $f_{\text{GSM900 TX}}$, Pin=35dBm	-	<-90	-70	dBc
2nd, 3rd, 4th Harmonics 1	$2,3,4f_o(1)$	G_TX1 to ANT, $f_o= f_{\text{GSM850 TX}}$, $f_{\text{GSM900 TX}}$, Pin=35dBm, CW ($T_a=-25^{\circ}\text{C}\sim+75^{\circ}\text{C}$)	-	-	-66	dBc

NJG1672LK4

■ ELECTRICAL CHARACTERISTICS 3 (G_TX2: GSM1800/1900 TX ON mode)

(General conditions: $T_a=+25^{\circ}\text{C}$, $Z_s=Z_l=50\Omega$, $V_{DD}=2.7\text{V}$, $V_{CTL(L)}=0\text{V}$, $V_{CTL(H)}=1.8\text{V}$)

PARAMETER	SYMBOL	CONDITIONS	NJRC Target SPEC.			UNITS
			MIN	TYP	MAX	
Frequency Range 3	$f_{\text{GSM1800 TX}}$	GSM1800 TX Band	1710	-	1785	MHz
Frequency Range 4	$f_{\text{GSM1900 TX}}$	GSM1900 TX Band	1850	-	1910	MHz
Insertion Loss 2(1)	LOSS2(1)	G_TX2 - ANT, $f_{\text{GSM1800 TX}}, f_{\text{GSM1900 TX}}$, Pin=32dBm	-	0.9	1.3	dB
Insertion Loss 2(2)	LOSS2(2)	G_TX2 - ANT, $f_{\text{GSM1800 TX}}, f_{\text{GSM1900 TX}}$, Pin=32dBm ($T_a=-25^{\circ}\text{C}\sim+75^{\circ}\text{C}$)	-	-	1.4	dB
Isolation 2(1)	ISL2(1)	G_TX2 to G_RX1, $f_{\text{GSM1800 TX}}, f_{\text{GSM1900 TX}}$, Pin=32dBm	32	37	-	dB
Isolation 2(2)	ISL2(2)	G_TX2 to G_RX2, $f_{\text{GSM1800 TX}}, f_{\text{GSM1900 TX}}$, Pin=32dBm	32	37	-	dB
Isolation 2(3)	ISL2(3)	G_TX2 to G_RX3, $f_{\text{GSM1800 TX}}, f_{\text{GSM1900 TX}}$, Pin=32dBm	27	30	-	dB
Isolation 2(4)	ISL2(4)	G_TX2 to G_RX4, $f_{\text{GSM1800 TX}}, f_{\text{GSM1900 TX}}$, Pin=32dBm	25	30	-	dB
Isolation 2(5)	ISL2(5)	G_TX2 to LCR_RX1, $f_{\text{GSM1800 TX}}, f_{\text{GSM1900 TX}}$, Pin=32dBm	32	37	-	dB
Isolation 2(6)	ISL2(6)	G_TX2 to LCR_RX2, $f_{\text{GSM1800 TX}}, f_{\text{GSM1900 TX}}$, Pin=32dBm	32	37	-	dB
VSWR 2(1)	VSWR2(1)	ANT port, $f_{\text{GSM1800 TX}}, f_{\text{GSM1900 TX}}$	-	1.2	1.5	
VSWR 2(2)	VSWR2(2)	G_TX2 port, $f_{\text{GSM1800 TX}}, f_{\text{GSM1900 TX}}$	-	1.2	1.5	
2nd Harmonic Suppression 2	2HS(2)	G_TX2 to ANT, $2 \times f_{\text{GSM1800 TX}}, 2 \times f_{\text{GSM1900 TX}}$	25	32	-	dB
3rd Harmonic Suppression 2	3HS(2)	G_TX2 to ANT, $3 \times f_{\text{GSM1800 TX}}, 3 \times f_{\text{GSM1900 TX}}$	25	45	-	dB
2nd Harmonics 2	2fo(2)	G_TX2 to ANT $f_0 = f_{\text{GSM1800 TX}}, f_{\text{GSM1900 TX}}$, Pin=32dBm	-	-85	-70	dBc
3rd Harmonics 2	3fo(2)	G_TX2 to ANT $f_0 = f_{\text{GSM1800 TX}}, f_{\text{GSM1900 TX}}$, Pin=32dBm	-	-85	-70	dBc
2nd, 3rd Harmonics 2	2,3fo(2)	G_TX2 to ANT, $f_0 = f_{\text{GSM1800 TX}}, f_{\text{GSM1900 TX}}$, Pin=32dBm, CW ($T_a=-25^{\circ}\text{C}\sim+75^{\circ}\text{C}$)	-	-	-66	dBc

■ ELECTRICAL CHARACTERISTICS 4 (G_RX1: GSM850 RX ON mode)

(General conditions: $T_a=+25^{\circ}\text{C}$, $Z_s=Z_l=50\Omega$, $V_{DD}=2.7\text{V}$, $V_{CTL(L)}=0\text{V}$, $V_{CTL(H)}=1.8\text{V}$)

PARAMETER	SYMBOL	CONDITIONS	NJRC Target SPEC.			UNITS
			MIN	TYP	MAX	
Frequency Range 5	$f_{\text{GSM850 RX}}$	GSM850 RX Band	869	-	894	MHz
Insertion Loss 3(1)	LOSS3(1)	ANT - G_RX1, $f_{\text{GSM850 RX}}$, Pin=10dBm	-	0.75	1.0	dB
Insertion Loss 3(2)	LOSS3(2)	ANT - G_RX1, $f_{\text{GSM850 RX}}$, Pin=10dBm ($T_a=-25^{\circ}\text{C}\sim+75^{\circ}\text{C}$)	-	-	1.1	dB
Isolation 3(1)	ISL3(1)	G_TX1 to ANT $f_{\text{GSM850 TX}}$, $f_{\text{GSM900 TX}}$, Pin=10dBm	25	30	-	dB
Isolation 3(2)	ISL3(2)	G_TX2 to ANT $f_{\text{GSM1800 TX}}$, $f_{\text{GSM1900 TX}}$, Pin=10dBm	30	35	-	dB
Isolation 3(3)	ISL3(3)	LCR_TX to ANT $f_{\text{LCR1.9G}}$, $f_{\text{LCR2.0G}}$, Pin=10dBm	25	32	-	dB
VSWR 3(1)	VSWR3(1)	ANT port, $f_{\text{GSM850 RX}}$	-	1.2	1.5	
VSWR 3(2)	VSWR3(2)	G_RX1 port, $f_{\text{GSM850 RX}}$	-	1.2	1.5	

■ ELECTRICAL CHARACTERISTICS 5 (G_RX2: GSM900 RX ON mode)

(General conditions: $T_a=+25^{\circ}\text{C}$, $Z_s=Z_l=50\Omega$, $V_{DD}=2.7\text{V}$, $V_{CTL(L)}=0\text{V}$, $V_{CTL(H)}=1.8\text{V}$)

PARAMETER	SYMBOL	CONDITIONS	NJRC Target SPEC.			UNITS
			MIN	TYP	MAX	
Frequency Range 6	$f_{\text{GSM900 RX}}$	GSM900 RX Band	925	-	960	MHz
Insertion Loss 4(1)	LOSS4(1)	ANT - G_RX2, $f_{\text{GSM900 RX}}$, Pin=10dBm	-	0.75	1.0	dB
Insertion Loss 4(2)	LOSS4(2)	ANT - G_RX2, $f_{\text{GSM900 RX}}$, Pin=10dBm ($T_a=-25^{\circ}\text{C}\sim+75^{\circ}\text{C}$)	-	-	1.1	dB
Isolation 4(1)	ISL4(1)	G_TX1 to ANT $f_{\text{GSM850 TX}}$, $f_{\text{GSM900 TX}}$, Pin=10dBm	25	30	-	dB
Isolation 4(2)	ISL4(2)	G_TX2 to ANT $f_{\text{GSM1800 TX}}$, $f_{\text{GSM1900 TX}}$, Pin=10dBm	30	35	-	dB
Isolation 4(3)	ISL4(3)	LCR_TX to ANT $f_{\text{LCR1.9G}}$, $f_{\text{LCR2.0G}}$, Pin=10dBm	25	32	-	dB
VSWR 4(1)	VSWR4(1)	ANT port, $f_{\text{GSM900 RX}}$	-	1.2	1.5	
VSWR 4(2)	VSWR4(2)	G_RX2 port, $f_{\text{GSM900 RX}}$	-	1.2	1.5	

NJG1672LK4

■ ELECTRICAL CHARACTERISTICS 6 (G_RX3: GSM1800 RX ON mode)

(General conditions: $T_a=+25^{\circ}\text{C}$, $Z_s=Z_l=50\Omega$, $V_{DD}=2.7\text{V}$, $V_{CTL(L)}=0\text{V}$, $V_{CTL(H)}=1.8\text{V}$)

PARAMETER	SYMBOL	CONDITIONS	NJRC Target SPEC.			UNITS
			MIN	TYP	MAX	
Frequency Range 7	$f_{\text{GSM1800 RX}}$	GSM1800 RX Band	1805	-	1880	MHz
Insertion Loss 5(1)	LOSS5(1)	ANT - G_RX3, $f_{\text{GSM1800 RX}}$, Pin=10dBm	-	0.9	1.3	dB
Insertion Loss 5(2)	LOSS5(2)	ANT - G_RX3, $f_{\text{GSM1800 RX}}$, Pin=10dBm ($T_a=-25^{\circ}\text{C}\sim+75^{\circ}\text{C}$)	-	-	1.4	dB
Isolation 5(1)	ISL5(1)	G_TX1 to ANT $f_{\text{GSM850 TX}}$, $f_{\text{GSM900 TX}}$, Pin=10dBm	25	30	-	dB
Isolation 5(2)	ISL5(2)	G_TX2 to ANT $f_{\text{GSM1800 TX}}$, $f_{\text{GSM1900 TX}}$, Pin=10dBm	30	35	-	dB
Isolation 5(3)	ISL5(3)	LCR_TX to ANT $f_{\text{LCR1.9G}}$, $f_{\text{LCR2.0G}}$, Pin=10dBm	25	32	-	dB
VSWR 5(1)	VSWR5(1)	ANT port, $f_{\text{GSM1800 RX}}$	-	1.2	1.5	
VSWR 5(2)	VSWR5(2)	G_RX3 port, $f_{\text{GSM1800 RX}}$	-	1.2	1.5	

■ ELECTRICAL CHARACTERISTICS 7 (G_RX4: GSM1900 RX ON mode)

(General conditions: $T_a=+25^{\circ}\text{C}$, $Z_s=Z_l=50\Omega$, $V_{DD}=2.7\text{V}$, $V_{CTL(L)}=0\text{V}$, $V_{CTL(H)}=1.8\text{V}$)

PARAMETER	SYMBOL	CONDITIONS	NJRC Target SPEC.			UNITS
			MIN	TYP	MAX	
Frequency Range 8	$f_{\text{GSM1900 RX}}$	GSM1900 RX Band	1930	-	1990	MHz
Insertion Loss 6(1)	LOSS6(1)	ANT - G_RX4, $f_{\text{GSM1900 RX}}$, Pin=10dBm	-	0.9	1.3	dB
Insertion Loss 6(2)	LOSS6(2)	ANT - G_RX4, $f_{\text{GSM1900 RX}}$, Pin=10dBm ($T_a=-25^{\circ}\text{C}\sim+75^{\circ}\text{C}$)	-	-	1.4	dB
Isolation 6(1)	ISL6(1)	G_TX1 to ANT $f_{\text{GSM850 TX}}$, $f_{\text{GSM900 TX}}$, Pin=10dBm	25	30	-	dB
Isolation 6(2)	ISL6(2)	G_TX2 to ANT $f_{\text{GSM1800 TX}}$, $f_{\text{GSM1900 TX}}$, Pin=10dBm	27	30	-	dB
Isolation 6(2)	ISL6(2)	LCR_TX to ANT $f_{\text{LCR1.9G}}$, $f_{\text{LCR2.0G}}$, Pin=10dBm	27	35	-	dB
VSWR 6(1)	VSWR6(1)	ANT port, $f_{\text{GSM1900 RX}}$	-	1.2	1.5	
VSWR 6(2)	VSWR6(2)	G_RX4 port, $f_{\text{GSM1900 RX}}$	-	1.2	1.5	

■ Electrical Characteristics 8 (LCR_TX: LCR1.9G/2.0G TX ON mode)

(General conditions: $T_a=+25^{\circ}\text{C}$, $Z_s=Z_l=50\Omega$, $V_{DD}=2.7\text{V}$, $V_{CTL(L)}=0\text{V}$, $V_{CTL(H)}=1.8\text{V}$)

PARAMETER	SYMBOL	CONDITIONS	NJRC Target SPEC.			UNITS
			MIN	TYP	MAX	
Frequency Range 9	$f_{LCR1.9G}$	LCR 1.9G Band	1880	-	1920	MHz
Frequency Range 10	$f_{LCR2.0G}$	LCR 2.0G Band	2010	-	2025	MHz
Insertion Loss 7(1)	LOSS7(1)	LCR_TX - ANT, $f_{LCR1.9G}$, $f_{LCR2.0G}$, Pin=26dBm	-	1.0	1.4	
Insertion Loss 7(2)	LOSS7(2)	LCR_TX - ANT, $f_{LCR1.9G}$, $f_{LCR2.0G}$, Pin=26dBm ($T_a=-25^{\circ}\text{C}\sim+75^{\circ}\text{C}$)	-	-	1.5	
Isolation 7(1)	ISL7(1)	LCR_TX to G_RX1, $f_{LCR1.9G}$, $f_{LCR2.0G}$, Pin=26dBm	32	37	-	dB
Isolation 7(2)	ISL7(2)	LCR_TX to G_RX2, $f_{LCR1.9G}$, $f_{LCR2.0G}$, Pin=26dBm	32	37	-	dB
Isolation 7(3)	ISL7(3)	LCR_TX to G_RX3, $f_{LCR1.9G}$, $f_{LCR2.0G}$, Pin=26dBm	32	37	-	dB
Isolation 7(4)	ISL7(4)	LCR_TX to G_RX4, $f_{LCR1.9G}$, $f_{LCR2.0G}$, Pin=26dBm	32	37	-	dB
Isolation 7(5)	ISL7(5)	LCR_TX to LCR_RX1, $f_{LCR1.9G}$, $f_{LCR2.0G}$, Pin=26dBm	25	30	-	dB
Isolation 7(6)	ISL7(6)	LCR_TX to LCR_RX2, $f_{LCR1.9G}$, $f_{LCR2.0G}$, Pin=26dBm	20	22	-	dB
VSWR 7(1)	VSWR7(1)	ANT port, $f_{LCR1.9G}$, $f_{LCR2.0G}$,	-	1.1	1.5	
VSWR 7(2)	VSWR7(2)	LCR_TX port, $f_{LCR1.9G}$, $f_{LCR2.0G}$,	-	1.1	1.5	
2nd Harmonic Suppression 3	2HS(3)	LCR_TX to ANT, $2 \times f_{LCR1.9G}$, $f_{LCR2.0G}$	25	35	-	dB
3rd Harmonic Suppression 3	3HS(3)	LCR_TX to ANT, $3 \times f_{LCR1.9G}$, $f_{LCR2.0G}$	25	35	-	dB
2nd Harmonics 3	2fo(3)	LCR_TX to ANT $f_0 = f_{LCR1.9G}$, $f_{LCR2.0G}$, Pin=26dBm	-	-90	-70	dBc
3rd Harmonics 3	3fo(3)	LCR_TX to ANT $f_0 = f_{LCR1.9G}$, $f_{LCR2.0G}$, Pin=26dBm	-	-95	-70	dBc
2nd, 3rd Harmonics 3	2,3fo(3)	LCR_TX to ANT, $f_0 = f_{LCR1.9G}$, $f_{LCR2.0G}$, Pin=26dBm, CW ($T_a=-25^{\circ}\text{C}\sim+75^{\circ}\text{C}$)	-	-	-66	dBc

NJG1672LK4

■ ELECTRICAL CHARACTERISTICS 9 (LCR_RX1: LCR 1.9G RX ON mode)

(General conditions: $T_a=+25^{\circ}\text{C}$, $Z_s=Z_l=50\Omega$, $V_{DD}=2.7\text{V}$, $V_{CTL(L)}=0\text{V}$, $V_{CTL(H)}=1.8\text{V}$)

PARAMETER	SYMBOL	CONDITIONS	NJRC Target SPEC.			UNITS
			MIN	TYP	MAX	
Frequency Range 9	$f_{LCR1.9G}$	LCR 1.9G Band	1880	-	1920	MHz
Insertion Loss 8(1)	LOSS8(1)	ANT - LCR_RX1, $f_{LCR1.9G}$, Pin=10dBm	-	0.6	0.95	dB
Insertion Loss 8(2)	LOSS8(2)	ANT - LCR_RX1, $f_{LCR1.9G}$, Pin=10dBm ($T_a=-25^{\circ}\text{C}\sim+75^{\circ}\text{C}$)	-	-	1.0	dB
Isolation 8(1)	ISL8(1)	G_TX1 to ANT $f_{GSM850\text{TX}}$, $f_{GSM900\text{TX}}$, Pin=10dBm	25	30	-	dB
Isolation 8(2)	ISL8(2)	G_TX2 to ANT $f_{GSM1800\text{TX}}$, $f_{GSM1900\text{TX}}$, Pin=10dBm	27	35	-	dB
Isolation 8(3)	ISL8(3)	LCR_TX to ANT $f_{LCR1.9G}$, $f_{LCR2.0G}$, Pin=10dBm	25	30	-	dB
VSWR 8(1)	VSWR8(1)	ANT port, $f_{LCR1.9G}$	-	1.1	1.5	
VSWR 8(2)	VSWR8(2)	LCR_RX1 port, $f_{LCR1.9G}$	-	1.1	1.5	

■ ELECTRICAL CHARACTERISTICS 10 (LCR_RX2: LCR 2.0G RX ON mode)

(General conditions: $T_a=+25^{\circ}\text{C}$, $Z_s=Z_l=50\Omega$, $V_{DD}=2.7\text{V}$, $V_{CTL(L)}=0\text{V}$, $V_{CTL(H)}=1.8\text{V}$)

PARAMETER	SYMBOL	CONDITIONS	NJRC Target SPEC.			UNITS
			MIN	TYP	MAX	
Frequency Range 10	$f_{LCR2.0G}$	LCR 2.0G Band	2010	-	2025	MHz
Insertion Loss 9(1)	LOSS9(1)	ANT - LCR_RX2, $f_{LCR2.0G}$, Pin=10dBm	-	0.6	0.95	dB
Insertion Loss 9(2)	LOSS9(2)	ANT - LCR_RX2, $f_{LCR2.0G}$, Pin=10dBm ($T_a=-25^{\circ}\text{C}\sim+75^{\circ}\text{C}$)	-	-	1.0	dB
Isolation 9(1)	ISL9(1)	G_TX1 to ANT $f_{GSM850\text{TX}}$, $f_{GSM900\text{TX}}$, Pin=10dBm	25	30	-	dB
Isolation 9(2)	ISL9(2)	G_TX2 to ANT $f_{GSM1800\text{TX}}$, $f_{GSM1900\text{TX}}$, Pin=10dBm	27	35	-	dB
Isolation 9(3)	ISL9(3)	LCR_TX to ANT $f_{LCR1.9G}$, $f_{LCR2.0G}$, Pin=10dBm	20	24	-	dB
VSWR 9(1)	VSWR9(1)	ANT port, $f_{LCR2.0G}$	-	1.1	1.5	
VSWR 9(2)	VSWR9(2)	LCR_RX2 port, $f_{LCR2.0G}$	-	1.1	1.5	

■ Electrical Characteristics 11 (Switching Time)

(General conditions: $T_a=+25^{\circ}\text{C}$, $Z_s=Z_l=50\Omega$, $V_{DD}=2.7\text{V}$, $V_{CTL(L)}=0\text{V}$, $V_{CTL(H)}=1.8\text{V}$)

PARAMETER	SYMBOL	CONDITIONS	NJRC Target SPEC.			UNITS
			MIN	TYP	MAX	
Switching Time	$T_{SW(1)}$	G_TX1 ↔ G_RX1 G_TX1 ↔ G_RX2 50% V_{CTL} to 10/90% RF	-	-	5	μs
	$T_{SW(2)}$	G_TX2 ↔ G_RX3 G_TX2 ↔ G_RX4 50% V_{CTL} to 10/90% RF	-	-	5	μs
	$T_{SW(3)}$	LCR_TX ↔ LCR_RX1 LCR_TX ↔ LCR_RX2 50% V_{CTL} to 10/90% RF	-	-	5	μs

NJG1672LK4

■ TERMINAL INFORMATION

No.	SYMBOL	DESCRIPTION
1	VC1	Control signal input terminal. This terminal is set to High-Level (+1.3~+3.0V) or Low-Level (-0.2~+0.2V).
2	GND	Ground terminal. Please connect this terminal with ground plane as close as possible for excellent RF performance.
3	G_RX1	RF receiving port.
4	G_RX2	RF receiving port.
5	G_RX3	RF receiving port.
6	G_RX4	RF receiving port.
7	GND	Ground terminal. Please connect this terminal with ground plane as close as possible for excellent RF performance.
8	G_TX2	RF transmitting port. This port is connected the LPF for GSM1800/1900 TX band into LTCC substrate.
9	GND	Ground terminal. Please connect this terminal with ground plane as close as possible for excellent RF performance.
10	G_TX1	RF transmitting port. This port is connected the LPF for GSM850/900 TX band into LTCC substrate.
11	GND	Ground terminal. Please connect this terminal with ground plane as close as possible for excellent RF performance.
12	ANT	RF transmitting/receiving port. Please connect an inductor with GND terminal for internal bias and ESD protections.
13	GND	Ground terminal. Please connect this terminal with ground plane as close as possible for excellent RF performance.
14	LCR_TX	RF transmitting port. This port is connected the LPF for LCR 1.9G/2.0G TX band into LTCC substrate.
15	GND	Ground terminal. Please connect this terminal with ground plane as close as possible for excellent RF performance.
16	LCR_RX2	RF receiving port.
17	LCR_RX1	RF receiving port.
18	GND	Ground terminal. Please connect this terminal with ground plane as close as possible for excellent RF performance.
19	VDD	Positive voltage supply terminal. The positive voltage (+2.6~+3.1V) has to be supplied. Please connect a bypass capacitor with GND terminal for excellent RF performance.
20	VC6	Control signal input terminal. This terminal is set to High-Level (+1.3~+3.0V) or Low-Level (-0.2~+0.2V).
21	VC5	Control signal input terminal. This terminal is set to High-Level (+1.3~+3.0V) or Low-Level (-0.2~+0.2V).
22	VC4	Control signal input terminal. This terminal is set to High-Level (+1.3~+3.0V) or Low-Level (-0.2~+0.2V).
23	VC3	Control signal input terminal. This terminal is set to High-Level (+1.3~+3.0V) or Low-Level (-0.2~+0.2V).
24	VC2	Control signal input terminal. This terminal is set to High-Level (+1.3~+3.0V) or Low-Level (-0.2~+0.2V).

APPLICATION CIRCUIT (Top View)

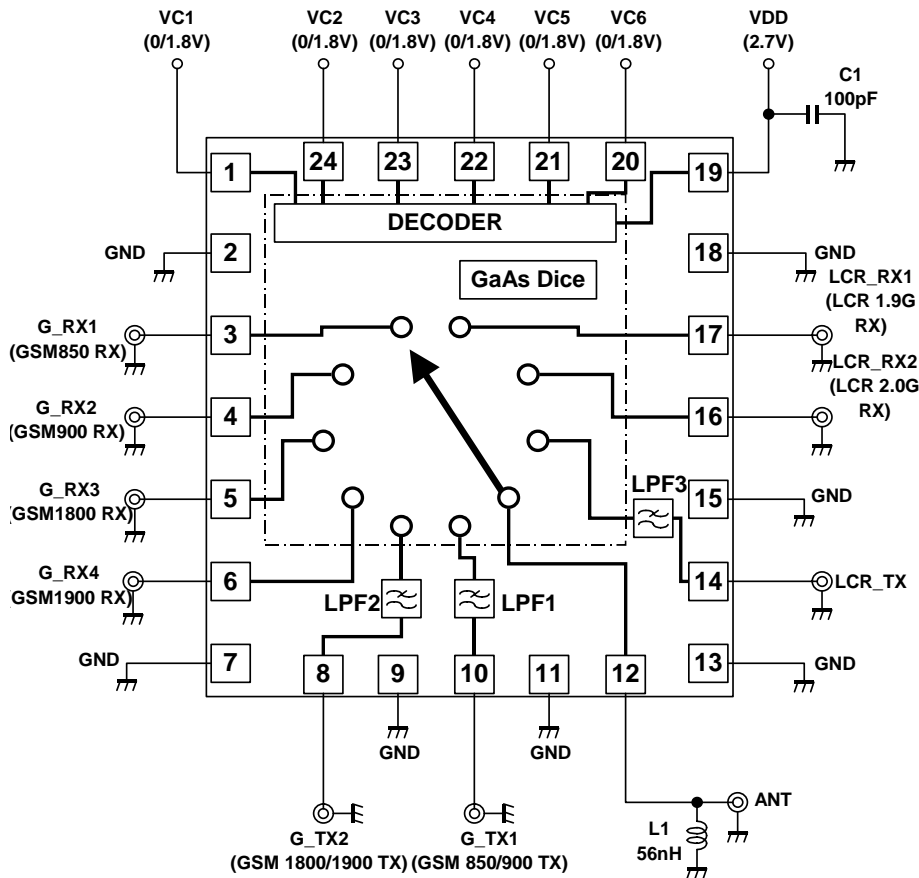

PIN CONNECTION

1. VC1
2. GND
3. G_RX1(GSM850 RX)
4. G_RX2(GSM900 RX)
5. G_RX3(GSM1800 RX)
6. G_RX4(GSM1900 RX)
7. GND
8. G_TX2(GSM1800/1900 TX)
9. GND
10. G_TX1(GSM850/900 TX)
11. GND
12. ANT
13. GND
14. LCR_TX(LCR 1.9G/2.0G TX)
15. GND
16. LCR_RX2(LCR 2.0G RX)
17. LCR_RX1(LCR 1.9G RX)
18. GND
19. VDD
20. VC6
21. VC5
22. VC4
23. VC3
24. VC2

Since all RF ports are biased at GND voltage, no DC cut capacitors are required on all RF ports.
When the RF port of the adjacent component is DC biased and connected with the RF port of NJG1672LK4, DC cut capacitor is required.

PARTS LIST

Parts number	Value	Notes
C1	100pF	MURATA(GRM15)
L1*	56nH	TAIYO-YUDEN(HK1005)

* The inductor of 56nH is required on ANT port in order to enhance ESD robustness.

NJG1672LK4

TEST PCB LAYOUT (Top View)

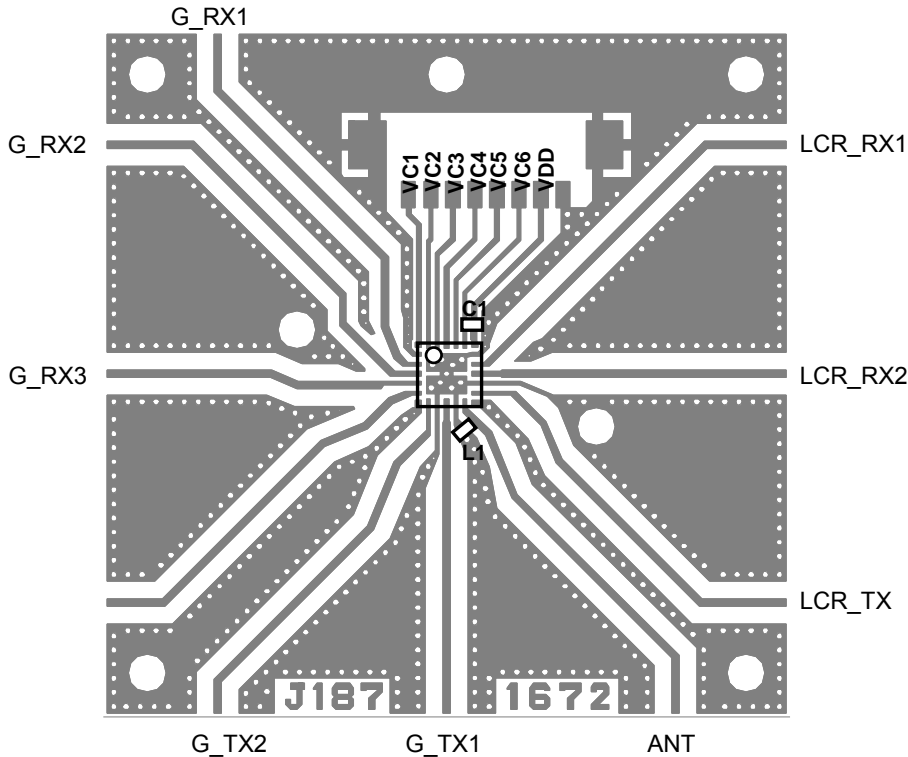

PCB SIZE= 39 x 39 mm
 PCB: FR-4, t=0.2mm
 CAPACITOR: size 1005
 MICROSTRIP LINE WIDTH=0.4mm

Board total losses (Connector and PCB)
 Ta=+25°C

Parameter	Mode	Frequency (MHz)	Loss (dB)
Insertion Loss	G_TX1	824	0.31
		849	0.31
		880	0.32
		915	0.32
	G_TX2	1710	0.54
		1785	0.55
		1850	0.57
	G_RX1	1910	0.57
		869	0.32
	G_RX2	894	0.32
		925	0.33
	G_RX3	960	0.35
		1805	0.55
	G_RX4	1880	0.57
		1930	0.58
	L_TX	1990	0.59
1880		0.57	
1920		0.57	
L_RX1	2010	0.59	
	2025	0.60	
L_RX2	1880	0.57	
	1920	0.57	
Harmonic Suppression	G_TX1 2fo	2010	0.59
		2025	0.60
		1648	0.52
		1698	0.53
	G_TX1 3fo	1760	0.53
		1830	0.55
		2472	0.71
		2547	0.72
	G_TX1 4fo	2640	0.76
		2745	0.80
		3296	0.97
		3396	1.00
	G_TX2 2fo	3520	1.02
		3660	1.03
		3420	1.01
		3570	1.03
	G_TX2 3fo	3700	1.06
		3820	1.06
		5130	1.48
		5355	1.52
L_TX 2fo	5550	1.52	
	5730	1.53	
	3760	1.05	
	3840	1.06	
L_TX 3fo	4020	1.09	
	4050	1.10	
	5640	1.52	
	5760	1.52	
		6030	1.55
		6075	1.56

PRECAUTIONS

- [1] For good RF performance, the ground terminals should be directly connected to the ground patterns and the through-holes as close as possible by using relatively wide pattern.
- [2] Please connect exposed GND PADS (bottom side of IC) to PCB GND using through holes.

RECOMMENDED SOLDER PADS (Top View, UNIT: mm)

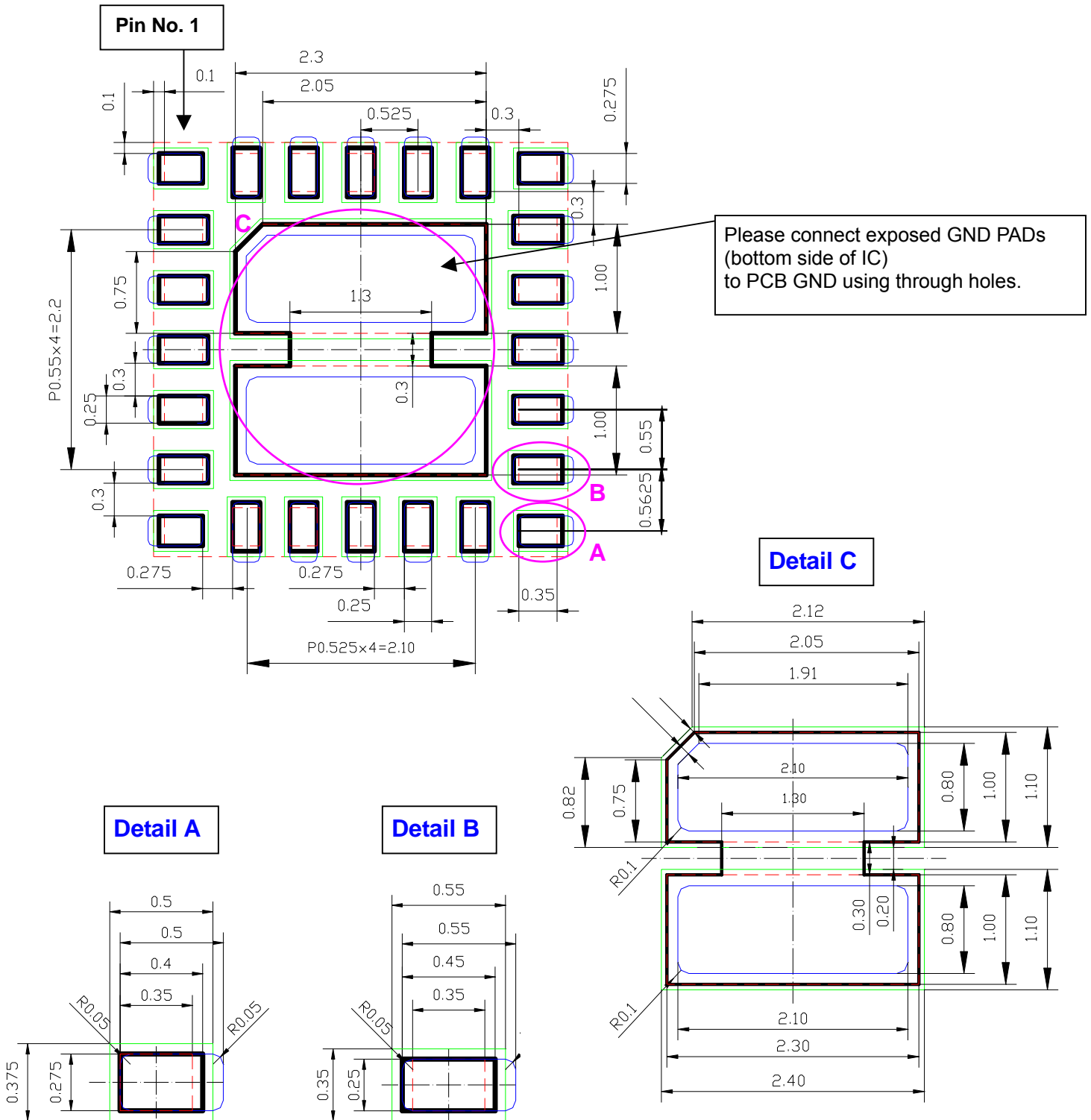

- - - Red dot lines indicate the package outline and LGA pads (Top View).
- Black solid lines indicate the recommended “Land area” (Top View).
- Green solid lines indicate the recommended “Resist open area” (Top View).
- Blue solid lines indicate the recommended “Solder mask open area” (Top View).

NJG1672LK4

PACKAGE OUTLINE (LCSP24-K4)

Top View

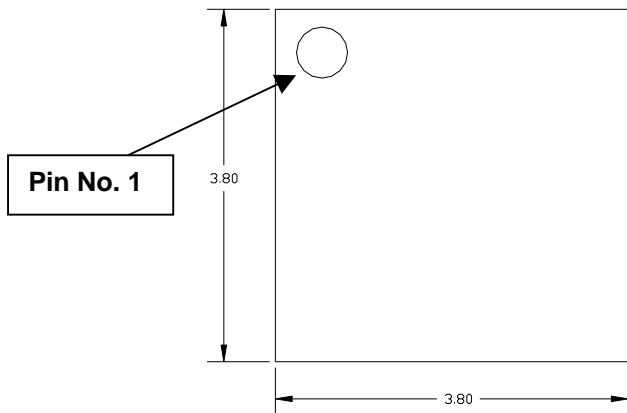

TERMINAL TREAT	Au
SUBSTRATE	LTCC
MOLDING MATERIAL	Epoxy resin
UNIT	mm
WEIGHT	36mg

Side View

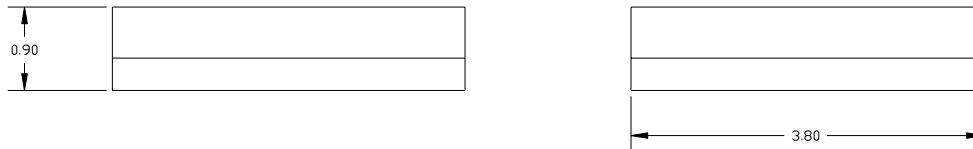

Bottom View

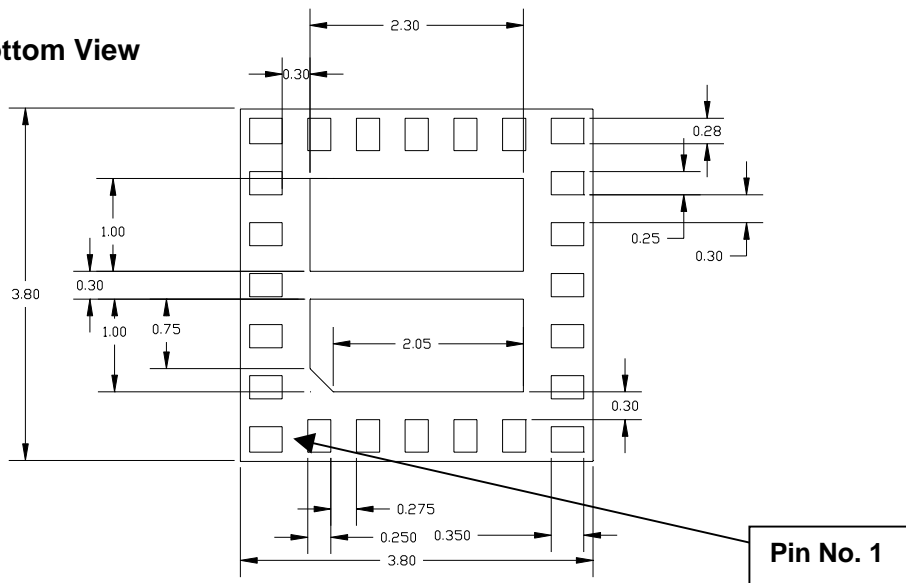

Cautions on using this product

- This product contains Gallium-Arsenide (GaAs) which is a harmful material.
- Do NOT eat or put into mouth.
 - Do NOT dispose in fire or break up this product.
 - Do NOT chemically make gas or powder with this product.
 - To waste this product, please obey the relating law of your country.

[CAUTION]

The specifications on this databook are only given for information, without any guarantee as regards either mistakes or omissions. The application circuits in this databook are described only to show representative usages of the product and not intended for the guarantee or permission of any right including the industrial rights.

This product may be damaged with electric static discharge (ESD) or spike voltage. Please handle with care to avoid these damages.