

PLEASE CHECK WWW.MOLEX.COM FOR LATEST PART INFORMATION

Part Number: [0191930307](#)
Status: **Active**
Description: VersaKrimp™ Ring Tongue Terminal for 2 AWG Wire

Documents:

[Drawing \(PDF\)](#) [RoHS Certificate of Compliance \(PDF\)](#)

Agency Certification

CSA LR18689
 UL E32244

General

Product Family Ring and Spade Terminals
 Series [19193](#)
 Comments Type I Noninsulated; Class 2
 Crimp Quality Equipment Yes
 Mil-Spec AS20659-114, MS20659-114
 Product Name VersaKrimp™
 Type Ring

Physical

Barrel Type Closed - Brazed
 Insulation None
 Material - Plating Mating Tin
 Packaging Type Bag
 Plating min: Mating (µin) 100
 Plating min: Mating (µm) 2.5
 Plating min: Termination (µin) 100
 Plating min: Termination (µm) 2.5
 Stud Size 3/8" (M9)
 Termination Interface: Style Crimp or Compression
 Wire Size AWG 2

Material Info

Old Part Number G-375-38

Reference - Drawing Numbers

Sales Drawing SD-19193-028

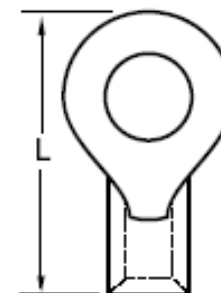

image - Reference only

Series

EU RoHS

ELV and RoHS Compliant

REACH SVHC

Contains SVHC: No

Halogen-Free

Status

Halogen-Free

China RoHS



Need more information on product environmental compliance?

Email productcompliance@molex.com
 For a multiple part number RoHS Certificate of Compliance, [click here](#)

Please visit the [Contact Us](#) section for any non-product compliance questions.

Search Parts in this Series

[19193Series](#)

Application Tooling | [FAQ](#)

Tooling specifications and manuals are found by selecting the products below. Crimp Height Specifications are then contained in the Application Tooling Specification document.

Global

Description	Product #
Putt Pump Dieless Head System	0192860065
Manual tool for Crimping non-insulated 8AWG thru 4/0 Terminals	0192940008
Manual Putt Pump Hydraulic System, Die set required	0192860117
Die Set (large) for the HHLS Hydraulic Crimper	0192900010
Hand Crimp Tool	0640013900

This document was generated on 04/12/2010

PLEASE CHECK WWW.MOLEX.COM FOR LATEST PART INFORMATION

MATERIAL NO. LOOSE PIECE	ENG. NO.	STUD SIZE	±.003 "S"	STOCK THICKNESS
191930303	G-375-10	10	.198	.075 (1.90)
191930305	G-375-14	1/4	.265	
191930309	G-375-56	5/16	.328	
191930307	G-375-38	3/8	.390	
191930311	G-375-76	7/16	.453	

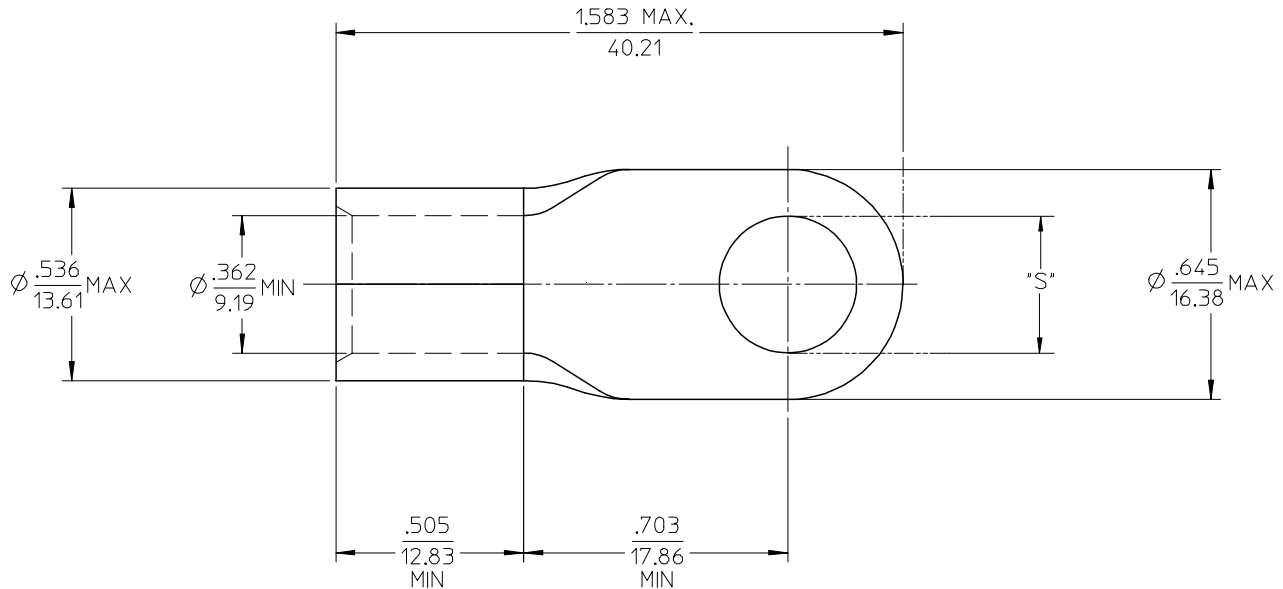

SALES DRAWING

- NOTE(S):
1. MATERIAL: COPPER
 2. PLATING: ELECTROPLATE TIN
 3. ALL DIMENSIONS IN INCHES/(MM).
 4. WIRE SIZE: 2 AWG
35 MM²

REVISED/UPDATE TO MK STDS EC NO: ETC2003-0315 DRWN:DMYRICK 2003/08/20 CHKD:HEB 2003/08/21 APPR:RDEROSS 2003/08/21	QUALITY SYMBOLS ▽ = 0 ▽ = 0	GENERAL TOLERANCES (UNLESS SPECIFIED)		SCALE 2:1	DESIGN UNITS INCH	THIRD ANGLE PROJECTION	REVISE ON CAD ONLY	
			mm	INCH	DIMENSION STYLE IN/MM		TITLE RING TONGUE TERMINAL VERSAKRIMP 2 AWG	
		4 PLACES	± ---	± ---	DRAWN BY DLM	DATE 03/07/11	MATERIAL NO. MOLEX INCORPORATED	
		3 PLACES	± ---	± .005	CHECKED BY HEB	DATE 03/07/11	DOCUMENT NO. (SEE CHART) SD-19193-028	SHEET NO. 1 OF 1
		2 PLACES	± 0.13	± .01	APPROVED BY RWD			
		1 PLACE	± 0.25	± ---	DATE 03/07/11			
		ANGULAR ±1/2°		THIS DRAWING CONTAINS INFORMATION THAT IS PROPRIETARY TO MOLEX INCORPORATED AND SHOULD NOT BE USED WITHOUT WRITTEN PERMISSION				
		DRAFT WHERE APPLICABLE MUST REMAIN WITHIN DIMENSIONS						