



## SINGLE PHASE BRIDGE RECTIFIER

**FBPC35005WN THRU FBPC3510WN**

**VOLTAGE RANGE  
CURRENT**

**50 to 1000 Volts  
35 Ampere**

### FEATURES

- Low cost
- This series is UL recognized under component index file number E127707
- High forward surge current capability
- Fast switching for high efficiency
- Integrally molded heatsink provide very low thermal resistance
- High isolation voltage from case to leads
- High temperature soldering guaranteed: 260°C / 10 seconds, at 5 lbs. (2.3kg) tension.

### MECHANICAL DATA

- Case: Molded plastic body
- Terminal: Plated 0.04" (1.02mm) diameter
- Polarity: Polarity symbols marked on case
- Mounting: Thru hole for #10 screw, 20 in.-lbs Torque max.
- Weight: 0.47 ounce, 13.4 gram

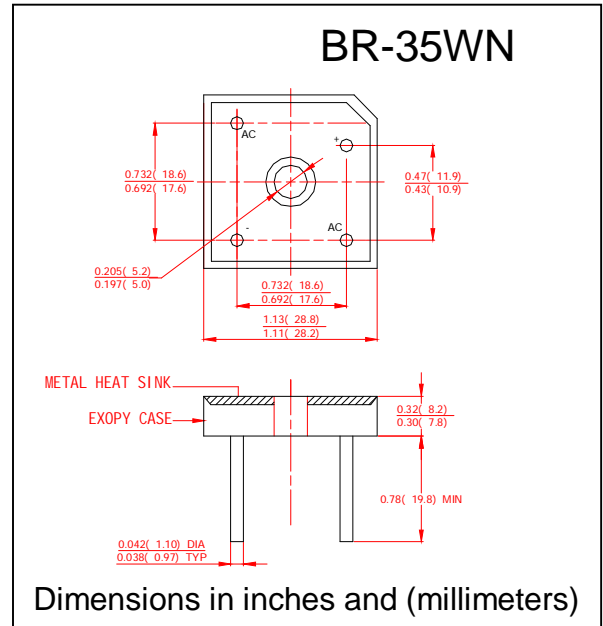

### MAXIMUM RATINGS AND ELECTRICAL CHARACTERISTICS

- Ratings at 25°C ambient temperature unless otherwise specified
- Single Phase, half wave, 60Hz, resistive or inductive load
- For capacitive load derate current by 20%

	SYMBOL	FBPC 35005WN	FBPC 3501WN	FBPC 3502WN	FBPC 3504WN	FBPC 3506WN	FBPC 3508WN	FBPC 3510WN	UNIT
Maximum Repetitive Peak Reverse Voltage	$V_{RRM}$	50	100	200	400	600	800	1000	Volts
Maximum RMS Voltage	$V_{RMS}$	35	70	140	280	420	560	700	Volts
Maximum DC Blocking Voltage	$V_{DC}$	50	100	200	400	600	800	1000	Volts
Maximum Average Forward Rectified Output Current, at $T_C = 50^\circ C$ (Note 1,2)	$I_{(AV)}$	25							Amps
Peak Forward Surge Current 8.3mS single half sine wave superimposed on rated load (JEDEC method)	$I_{FSM}$	300							Amps
Rating for Fusing ( $t < 8.3mS$ )	$I^2t$	664							$A^2s$
Maximum Instantaneous Forward Voltage Drop per Bridge element at 17.5 A	$V_F$	1.2				1.3			Volts
Maximum DC Reverse Current at Rated DC Blocking Voltage per element	$T_A = 25^\circ C$	10							$\mu A$
	$T_A = 100^\circ C$	1.0							mA
Maximum DC Reverse recovery time(Note3)	$T_{rr}$	150				250	500		NS
Isolation Voltage from case to lead	$V_{ISO}$	2500							$V_{AC}$
Typical Thermal Resistance (Note 1,2)	$R_{\theta Jc}$	2.0							$^\circ C/W$
Operating Temperature Rang	$T_J$	(-65 to +150)							$^\circ C$
Storage Temperature Rang	$T_{STG}$	(-65 to +150)							$^\circ C$

### Notes:

1. Unit mounted on 9" x 3.5" x 4.6" (23cm x 9cm x 11.8cm) AL finned Plate
2. Bolt down on heat-sink with silicon thermal compound between bridge and mounting surface for maximum heat transfer efficiency with #10 screw
3. Reverse recovery test conditions:  $I_F=0.5A, I_R=1.0A, I_{RR}=0.25A$



## SINGLE PHASE BRIDGE RECTIFIER

**FBPC35005WN THRU FBPC3510WN**

VOLTAGE RANGE  
CURRENT

50 to 1000 Volts  
35 Ampere

### RATINGS AND CHARACTERISTIC CURVES FBPC35005WN THRU FBPC3510WN

FIG.1- DERATING CURVE FOR  
OUTPUT RECTIFIED CURRENT

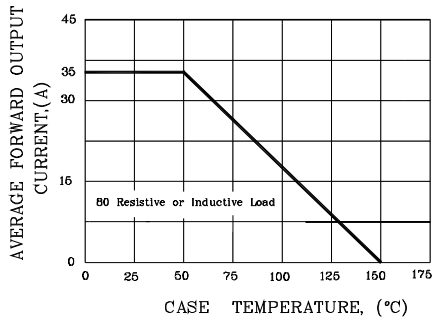

FIG.2- MAXIMUM NON-REPETITIVE PEAK  
FORWARD SURGE CURRENT

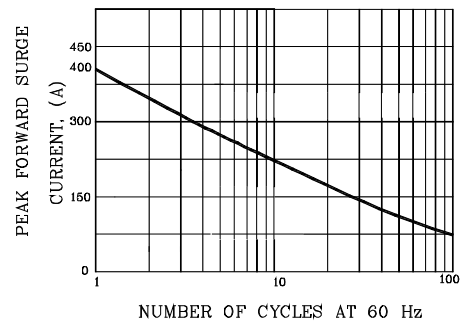

FIG.3- TYPICAL FORWARD CHARACTERISTICS  
PER DIODE

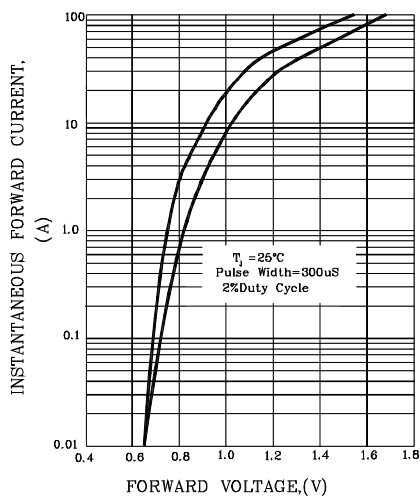

FIG.4- TYPICAL REVERSE CHARACTERISTICS  
PER DIODE

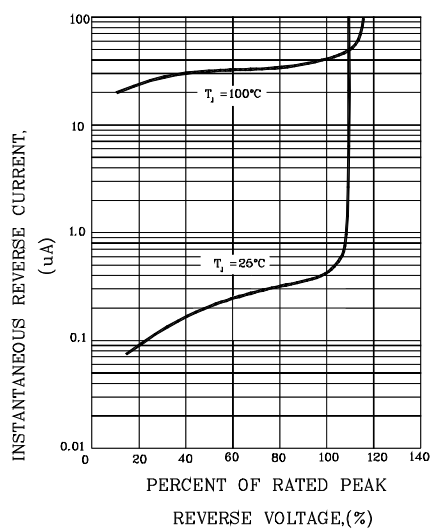

FIG.4- TYPICAL JUNCTION CAPACITANCE

