

PLEASE CHECK WWW.MOLEX.COM FOR LATEST PART INFORMATION

Part Number: **0008560106**
Status: **Active**
Overview: kk
Description: 3.96mm (.156") Pitch KK® Crimp Terminal 2478, 18-24 AWG, Bag, Brass, 0.51µm (20µ") Selective Gold (Au)

Documents:

[Drawing \(PDF\)](#) [RoHS Certificate of Compliance \(PDF\)](#)
[Product Specification PS-08-50 \(PDF\)](#)

General

Product Family Crimp Terminals
 Series 2478
 Crimp Quality Equipment Yes
 Overview kk
 Product Name KK®

Physical

Gender Female
 Material - Metal Brass
 Material - Plating Mating Gold
 Material - Plating Termination Gold
 Packaging Type Bag
 Plating min: Mating (µin) 15
 Plating min: Mating (µm) 0.375
 Plating min: Termination (µin) 2
 Plating min: Termination (µm) 0.05
 Termination Interface: Style Crimp or Compression
 Wire Insulation Diameter 2.79mm (.110") max.
 Wire Size AWG 18, 20, 22, 24
 Wire Size mm² N/A

Material Info

Old Part Number 2478-1-(550)L

Reference - Drawing Numbers

Packaging Specification PK-2759-001
 Product Specification PS-08-50
 Sales Drawing SD-2478

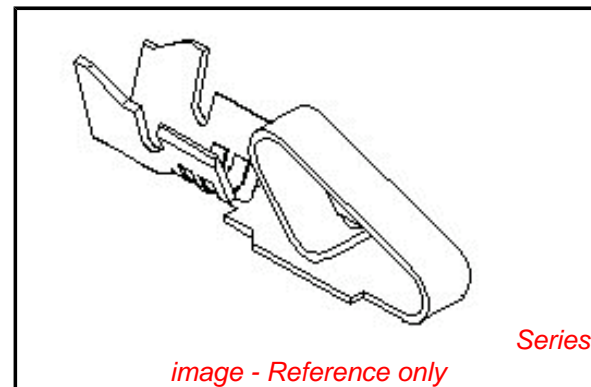

image - Reference only

EU RoHS

ELV and RoHS Compliant
REACH SVHC
Contains SVHC: No
Halogen-Free Status

China RoHS



Halogen-Free

Need more information on product environmental compliance?

Email productcompliance@molex.com
 For a multiple part number RoHS Certificate of Compliance, [click here](#)

Please visit the [Contact Us](#) section for any non-product compliance questions.

Search Parts in this Series

[2478Series](#)

Use With

[2574](#) , [2139](#) , [41695](#) , [3069](#) , [6422](#) , [5265](#) , [5239](#)

Application Tooling | FAQ

Tooling specifications and manuals are found by selecting the products below. Crimp Height Specifications are then contained in the Application Tooling Specification document.

Global

Description	Product #
Hand Crimper	0638117500
Extraction Tool	0011030016

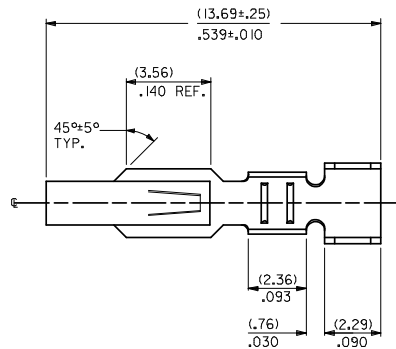
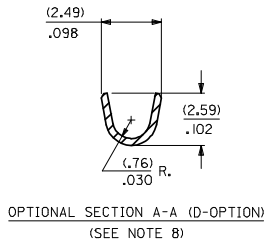
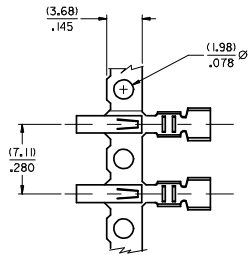

2478- * - * - *

MATERIAL CODE
(.27)/.0106 THK
1=BRASS
3=PHOS BRONZE

WINDING SPEC.
A=PER ES-339-A
BLANK=PER ES-339-B
L=LOOSE

OPTION CODE
BLANK=AS SHOWN
C=CAT EAR OPTION
D=OPTIONAL CONDUCTOR CRIMP (FOR IRELAND) (SEE OPT. SECTION A-A) WITHOUT CAT EARS
E=LOW INSERTION FORCE OPTION

FINISH: PER SDES-88
(P909) *OVERALL HOT TIN DIP: 2.54 MICROMETERS MIN.
(550) SELECT GOLD: 0.38 MICROMETERS MIN.
OVERALL GOLD FLASH: 0.05 MICROMETERS MIN.
OVERALL NICKEL UNDERPLATE: 0.76 MICROMETERS MIN.
(555) SELECT GOLD: 0.38 MICROMETERS MIN.
OVERALL NICKEL UNDERPLATE: 0.76 MICROMETERS MIN.

*THE PRIMARY SHIPPING CARTON WILL BE LABELED "COMPLIANT TO RoHS DIRECTIVE 2002/95/EC AND ELV ANNEX II OF DIRECTIVE 2000/53/EC". CARTONS WITHOUT THIS LABEL MAY CONTAIN PRODUCT WITH TIN/LEAD PLATING.

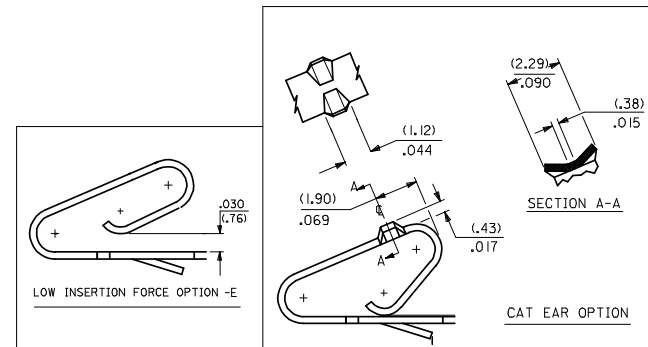
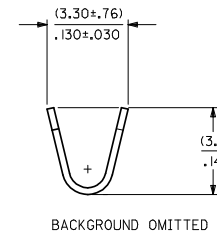
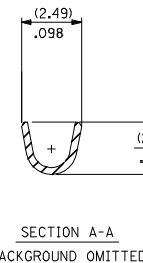
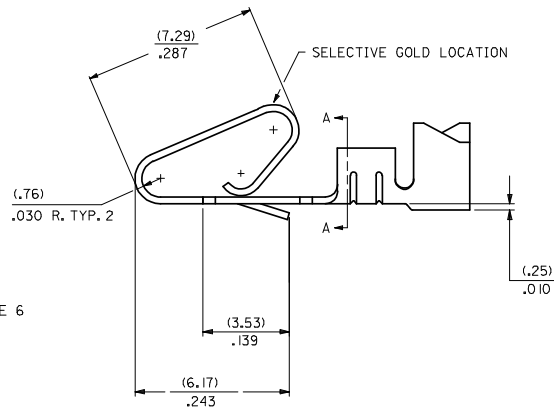
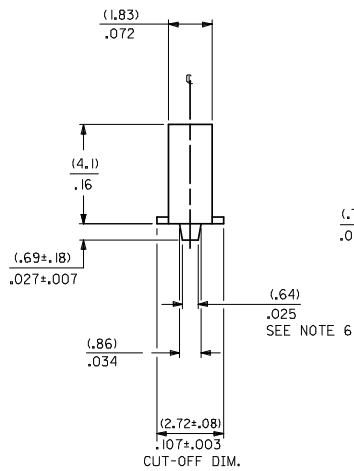

- NOTES:
- CRIMP ACCEPTS 18 TO 24 GA. WIRE WITH (2.79)/.110 MAX. INSUL. DIA.; WHEN USED WITH 2574 CONNECTOR, (2.54)/.100 MAX. INSUL. DIA. WHEN USED WITH 2139 CONNECTOR; HOUSING 41695 IS RECOMMENDED FOR OVER (2.54)/.100 DIA. INSULATION. CRIMP ACCEPTS (3.00)/.118 MAX. INSUL. DIA. WITH SPECIAL TOOLING.
 - DIMENSIONS GIVEN ACROSS CENTERLINES ARE SYMMETRICAL ABOUT THOSE CENTERLINES WITHIN HALF THE TOTAL TOLERANCE.
 -
 -
 -
 - (.86±.05)/.034±.002 IS AN OPTIONAL DESIGN.
 - THIS PART CONFORMS TO PRODUCT SPEC. 08-50.
 - CONDUCTOR CRIMP FOR 16 AWG. WIRE WITH .110 MAX. INSULATION DIA.

CHANGE TO ME10 EC NO: UCP2005-0902 DRAWN BY: DRWADRATNOL 2004/11/16 CHKD BY: CHKDSAMIEC 2006/03/28 APPROVED BY: APPRMMARJULIS 2004/10/28	QUALITY SYMBOLS ▽=0 ▽=0	GENERAL TOLERANCES (UNLESS SPECIFIED)		DIMENSION STYLE IN/MM		SCALE	DESIGN UNITS INCH	THIRD ANGLE PROJECTION
		4 PLACES ±.005 ±.005	3 PLACES ±.005 ±.010	2 PLACES ±.025 ±.014	1 PLACE ±.036 ±.014	ANGULAR ±1/2°	DRAWN BY: SAMIEC 06/03/86	DATE: 06/03/86
DRAFT WHERE APPLICABLE MUST REMAIN WITHIN DIMENSIONS		MATERIAL NO. SEE CHART		DOCUMENT NO. SD-2478		MOLEX INCORPORATED		
SIZE D		THIS DRAWING CONTAINS INFORMATION THAT IS PROPRIETARY TO MOLEX INCORPORATED AND SHOULD NOT BE USED WITHOUT WRITTEN PERMISSION		SHEET NO. 1 OF 2				

2478-1-(****)*			2478-3-(****)*			2478-IC-(****)*			2478-3C-(****)*			2478-ID-(****)*			2478-3E-(****)*		
PART NO.	ENG. NO.		PART NO.	ENG. NO.		PART NO.	ENG. NO.		PART NO.	ENG. NO.		PART NO.	ENG. NO.		PART NO.	ENG. NO.	
08-50-0105	2478-1-(P909)		08-52-0071	2478-3-(P909)		08-50-0014	2478-IC-(P909)		08-52-0044	2478-3C-(P909)		08-50-0055	2478-ID-(P909)			2478-3E-(P909)	
08-50-0106	2478-1-(P909)L		08-52-0072	2478-3-(P909)L		08-50-0045	2478-IC-(P909)L		08-52-0045	2478-3C-(P909)L		08-50-0056	2478-ID-(P909)L			2478-3E-(P909)L	
08-56-0105	2478-1-(550)		08-65-0114	2478-3-(555)		08-50-0047	2478-IC-(P102)		08-52-0023	2478-3C-(102)						2478-3E-(555)	
08-56-0106	2478-1-(550)L		08-65-0115	2478-3-(555)L		08-50-0046	2478-IC-(P102)L		08-52-0024	2478-3C-(102)L						2478-3E-(555)L	
08-55-0103	2478-1-(555)		08-52-0073	2478-3-(P102)		08-50-0091	2478-IC-(102)		08-52-0027	2478-3C-(122)						2478-3E-(550)	
08-55-0104	2478-1-(555)L		08-52-0074	2478-3-(P102)L		08-50-0093	2478-IC-(102)L		08-52-0027	2478-3C-(122)L						2478-3E-(550)L	
08-50-0146	2478-1-(109)		08-52-0811	2478-3-(102)					08-52-0047	2478-3C-(P102)							
08-50-0147	2478-1-(109)L		08-52-0812	2478-3-(102)L					08-52-0046	2478-3C-(P102)							
08-50-0119	2478-1-(122)		08-50-0281	2478-3-(122)													
08-50-0120	2478-1-(122)L																
08-50-0271	2478-1-(P909)A		08-58-0121	2478-3-(550)													
	2478-1-(507)		08-58-0122	2478-3-(550)L													
	2478-1-(507)L		08-58-0103	2478-3-(591)													
08-56-0153	2478-1-(507)		08-58-0104	2478-3-(591)L													
08-56-0154	2478-1-(506)		08-58-0114	2478-3-(558)													
	2478-1-(506)L		08-58-0115	2478-3-(558)L													
08-50-0015	2478-1-(102)																
08-50-0016	2478-1-(102)L																
08-52-0114	2478-1-(P909)																
08-52-0115	2478-1-(P909)L																
	2478-1-(132)																
	2478-1-(132)L																
08-50-0001	2478-1-(P224)																
08-50-0006	2478-1-(P224)L																
08-50-0063	2478-1-(224)																
08-50-0064	2478-1-(224)L																
08-55-0133	2478-1-(561)																
08-55-0134	2478-1-(561)L																
08-50-0073	2478-1-(P102)																
08-50-0074	2478-1-(P102)L																

SEE SHEET I	SEE SHEET I	DIMENSIONS SHOWN ARE IN INCH UNLESS OTHERWISE SPECIFIED DIMENSIONS ARE IN MILLIMETERS 1 INCH = 25.4 MM 1 MILLIMETER = 0.03937 INCH 1 INCH = 25.4 MM 1 MILLIMETER = 0.03937 INCH DIMENSIONS ARE IN MILLIMETERS UNLESS OTHERWISE SPECIFIED	DIMENSIONS SHOWN ARE IN INCH UNLESS OTHERWISE SPECIFIED DIMENSIONS ARE IN MILLIMETERS 1 INCH = 25.4 MM 1 MILLIMETER = 0.03937 INCH 1 INCH = 25.4 MM 1 MILLIMETER = 0.03937 INCH DIMENSIONS ARE IN MILLIMETERS UNLESS OTHERWISE SPECIFIED	DIMENSIONS SHOWN ARE IN INCH UNLESS OTHERWISE SPECIFIED DIMENSIONS ARE IN MILLIMETERS 1 INCH = 25.4 MM 1 MILLIMETER = 0.03937 INCH 1 INCH = 25.4 MM 1 MILLIMETER = 0.03937 INCH DIMENSIONS ARE IN MILLIMETERS UNLESS OTHERWISE SPECIFIED	DIMENSIONS SHOWN ARE IN INCH UNLESS OTHERWISE SPECIFIED DIMENSIONS ARE IN MILLIMETERS 1 INCH = 25.4 MM 1 MILLIMETER = 0.03937 INCH 1 INCH = 25.4 MM 1 MILLIMETER = 0.03937 INCH DIMENSIONS ARE IN MILLIMETERS UNLESS OTHERWISE SPECIFIED
SEE SHEET I	SEE SHEET I		SEE SHEET I	SEE SHEET I	SEE SHEET I
SEE SHEET I	SEE SHEET I		SEE SHEET I	SEE SHEET I	SEE SHEET I
SEE SHEET I	SEE SHEET I		SEE SHEET I	SEE SHEET I	SEE SHEET I
SEE SHEET I	SEE SHEET I		SEE SHEET I	SEE SHEET I	SEE SHEET I
SEE SHEET I	SEE SHEET I		SEE SHEET I	SEE SHEET I	SEE SHEET I
SEE SHEET I	V	SEE SHEET I	SEE SHEET I	SEE SHEET I	
LTR. REVISIONS	LTR. REVISIONS	DATE: 06/12/86	SCALE: 1:1	CRIMP TERMINAL .156 18/24 AWG WIRE MOLEX INCORPORATED U.S.A. SHEET NO. 2 DATE 06/12/86 SEE CHARTS SD-2478 THE DRAWING CONTAINS INFORMATION THAT IS PROPRIETARY TO MOLEX INC. AND SHALL BE KEPT STRICTLY CONFIDENTIAL.	