

1. Description

This is a transmissive optical encoder sensor for closed-loop position detection system. It consists of a collimated Red LED and a multiple sets of photo detectors OEIC enclosed in a C-shape plastic housing.

The photo detectors IC is designed by CMOS process which with the features of low consumption current and wide operating voltage.

The collimated light source consists of a 650nm AlInGaP LED and a collimated lens. By the design of this highly collimated light source to cooperate with the photo detectors IC, this optical encoder is extremely tolerant to mounting misalignment.

1.1 Features

- 150 LPI (169 μ m) resolutions
- For linear and rotary applications
- Insensitive to radial and axial play
- TTL 3.3V or 5V CMOS compatible
- Two channels quadrature digital output, no signal adjustment required
- RoHS Compliance

1.2 Applications

- Facsimile
- Printer
- Plotter
- Scanner
- Copier

2. Outline Dimensions

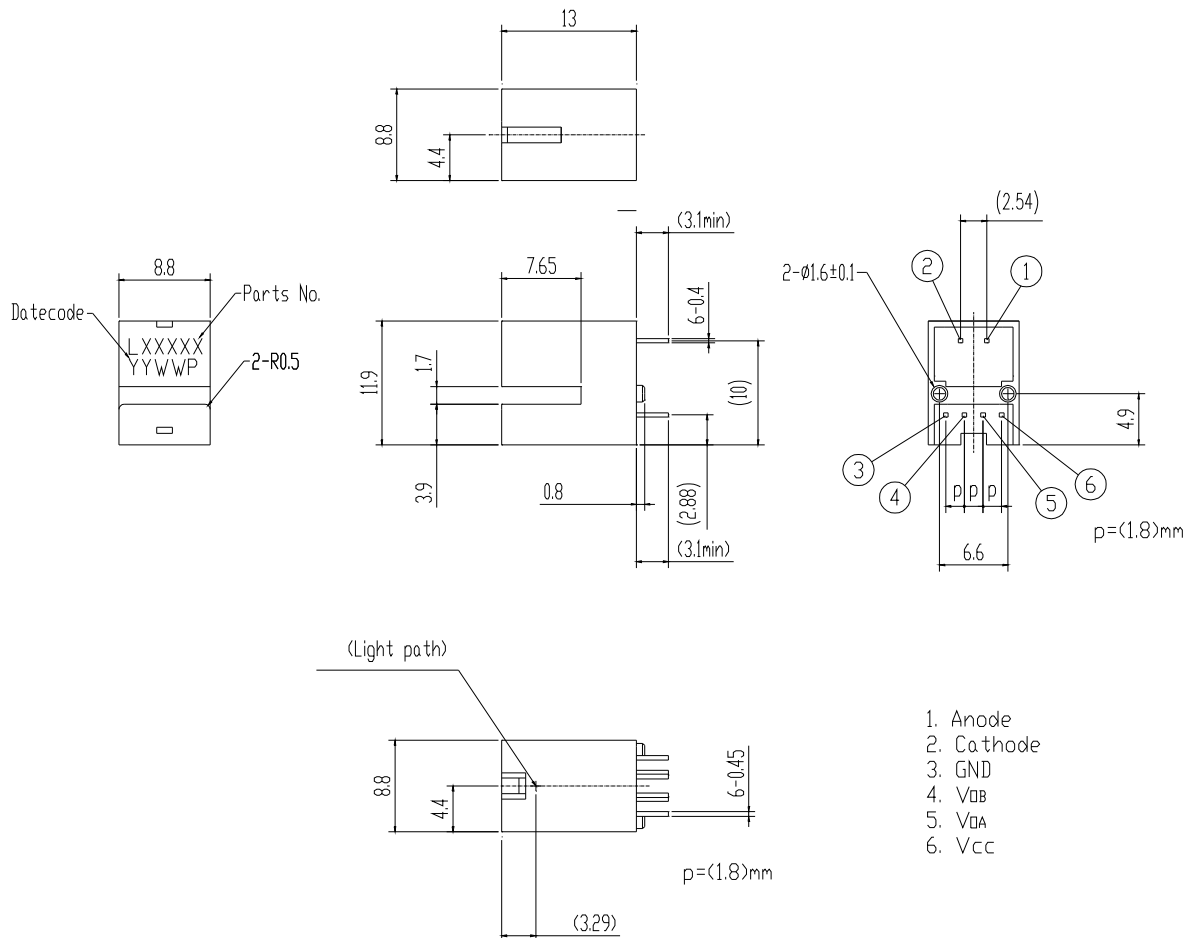

1. Unspecified tolerances shall be ± 0.3
2. Dimensions in parenthesis are shown for reference.
3. Date code was expressed 4 digits at second row:
 First 2 digits: Last 2 digits of production year.
 Last 2 digits: Production week.

3. Rating and Characteristics

3.1 Block diagram

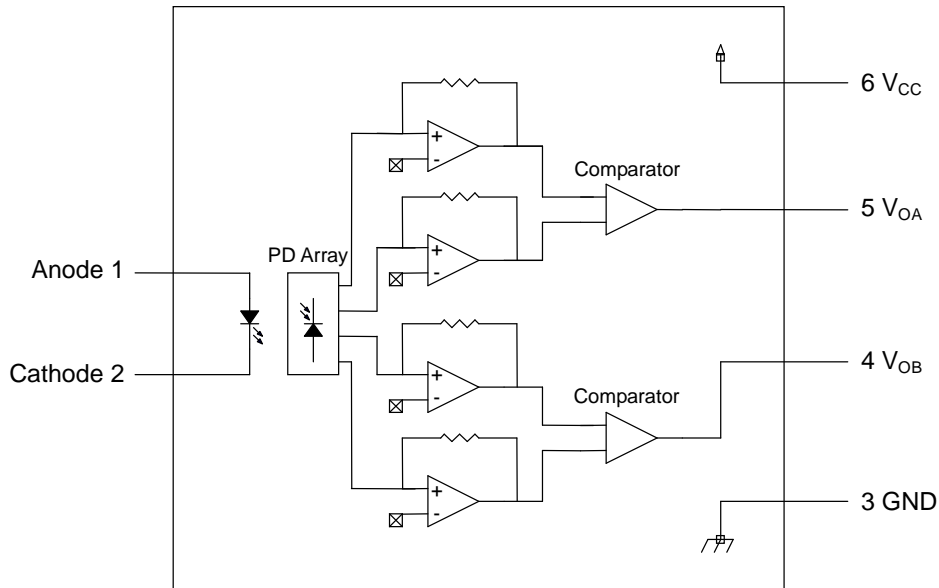

3.2 Absolute maximum ratings At Ta = 25°C

Parameter		Symbol	Rating	Unit
Input	Forward current*	I_F	30	mA
	Reverse voltage	V_R	5	V
Output	Supply voltage	V_{CC}	7	V
	Low level output current	I_{OL}	4	mA
	Power dissipation*	P_O	150	mW
Operating temperature		T_{opr}	-10 to +70	°C
Storage temperature		T_{stg}	-40 to +80	°C
Soldering temperature**		T_{sol}	260	°C

* The derating factors of absolute maximum ratings due to ambient temperature are shown in Fig 1,2.

** For 5 seconds.

3.3 Electro-optical characteristics at Ta = 25°C

Parameter		Symbol	MIN.	TYP.	MAX.	Test Condition	Unit
Input	Forward voltage	V_F	-	1.8	2.4	$I_F = 20\text{mA}$	V
	Reverse current	I_R	-	-	100	$V_R = 5\text{V}$	μA
	Driving current	I_D	10	16	25	$V_{CC} = 5\text{V}$	mA
Output	Operating supply voltage	V_{CC}	2.7	5.0	5.5	-	V
	Low level output voltage	V_{OL}	-	0.1	0.4	$V_{CC} = 5\text{V}, I_F = 10\text{mA}$ $I_{OL} = 4\text{mA}$	V
	High level output voltage	V_{OH}	2.4	4.9	-	$V_{CC} = 5\text{V}, I_F = 10\text{mA}$ $I_{OH} = 400\mu\text{A}$	V
	Current consumption	I_{CC}	-	1	3	$V_{CC} = 5\text{V}, I_F = 10\text{mA}$ All CH. at logic low	mA
Transfer characteristics *	Duty cycle	$D_{A, B}$	40	50	60	$V_{CC} = 5\text{V}$ $I_F = 10\text{mA}$ $f = 10\text{kHz}$ $Z = 0.1 \text{ to } 1.7\text{mm}$	%
	Phase difference	$\theta_{AB1 \text{ to } 4}$	60	90	120		°
	Response	t_r	-	0.1	1.0		μs
		t_f	-	0.1	1.0		
Response frequency	f_{MAX}	-	20	50	$V_{CC} = 5\text{V}, I_F = 10\text{mA}$	kHz	

* The test condition is according to Fig.3.

Transfer characteristics value does not include any error of linear scale.

Z stands for distance between scale surface (patterned surface) and detector holder surface.

3.4 Output waveform

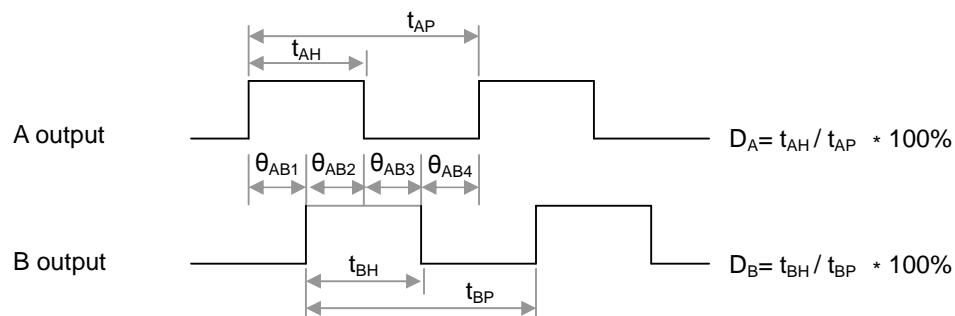

Refer to note2 in Fig.3 for the moving direction of scale.

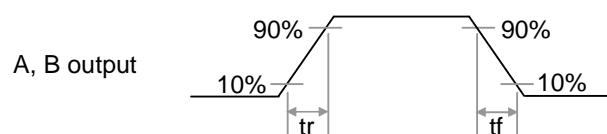

Fig. 1 LED forward current vs. ambient temperature

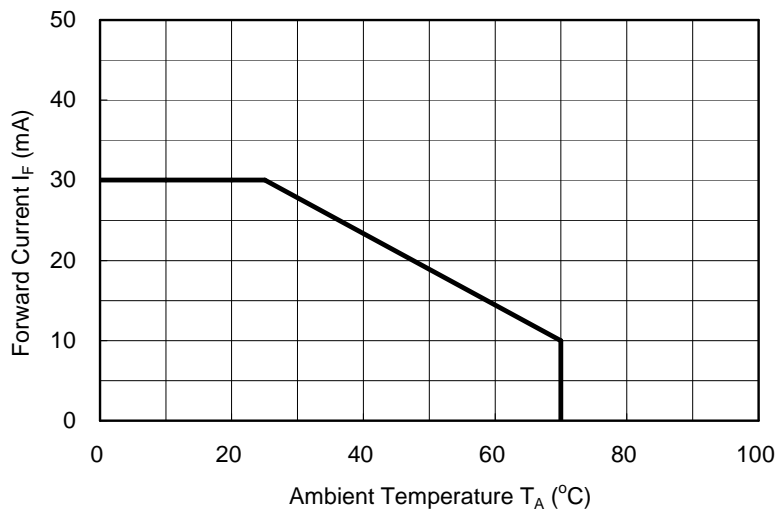

Fig. 2 LED Output power dissipation vs. ambient temperature

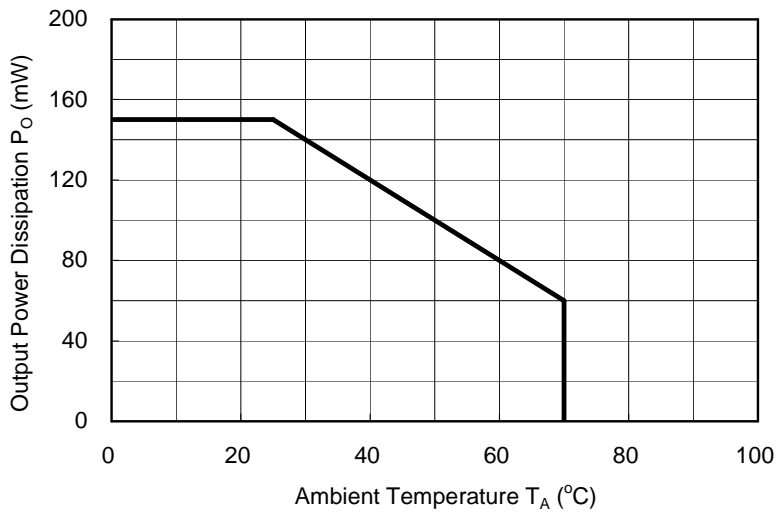
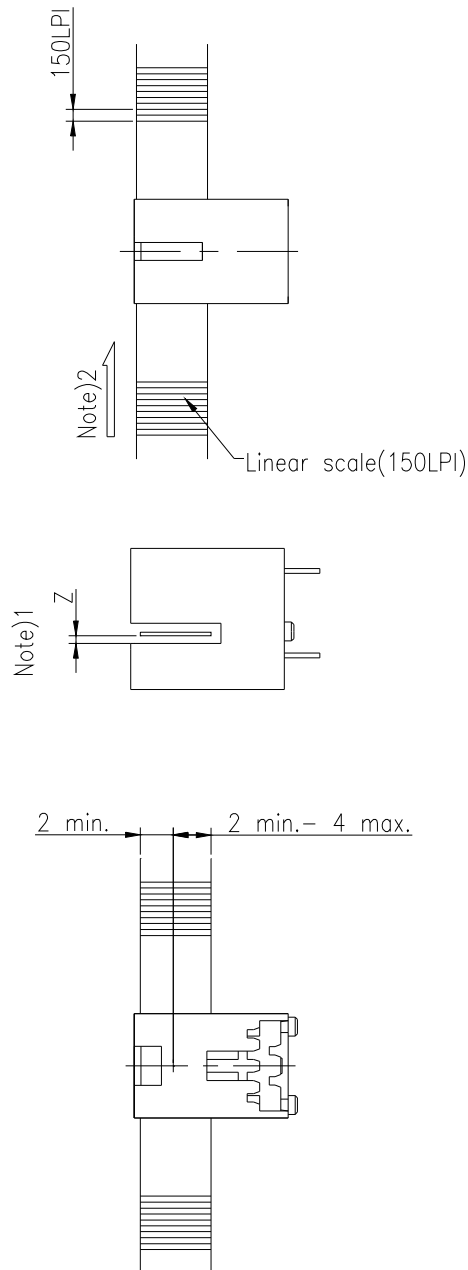

Fig. 3 Test Conditions



Note:

1. Distance between scale surface (patterned surface) and detector holder surface
2. The moving direction of scale against output waveform (Refer to 3.4)

4. Recommend application circuit

4.1 Apply 3.3 Volts

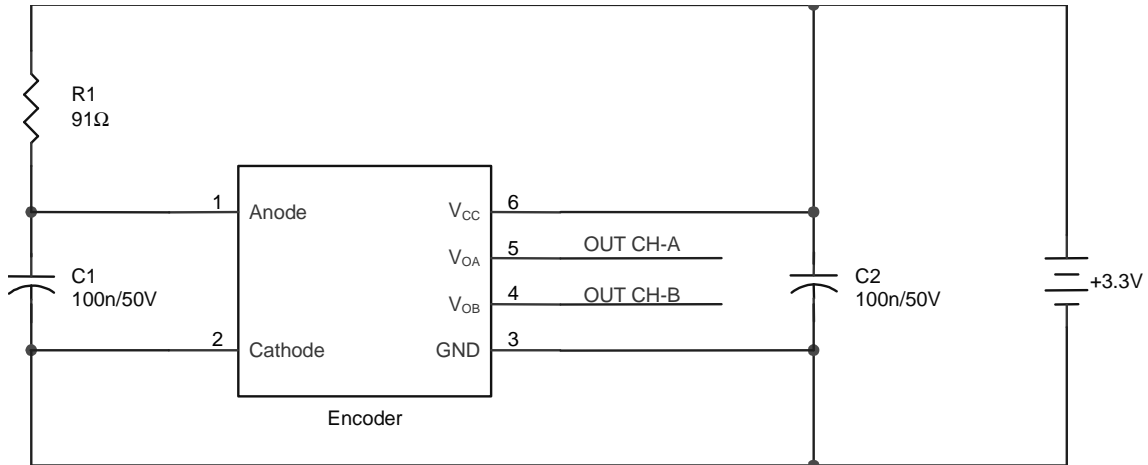

4.2 Apply 5.0 Volts

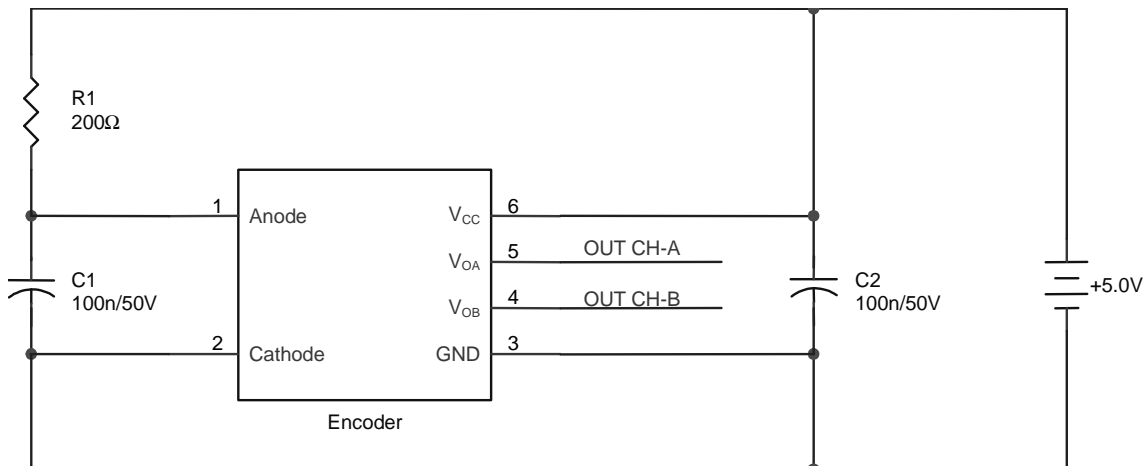

Note: Recommended no pull-up on Channel A & Channel B.

5. Packing

5.1 Packing Format

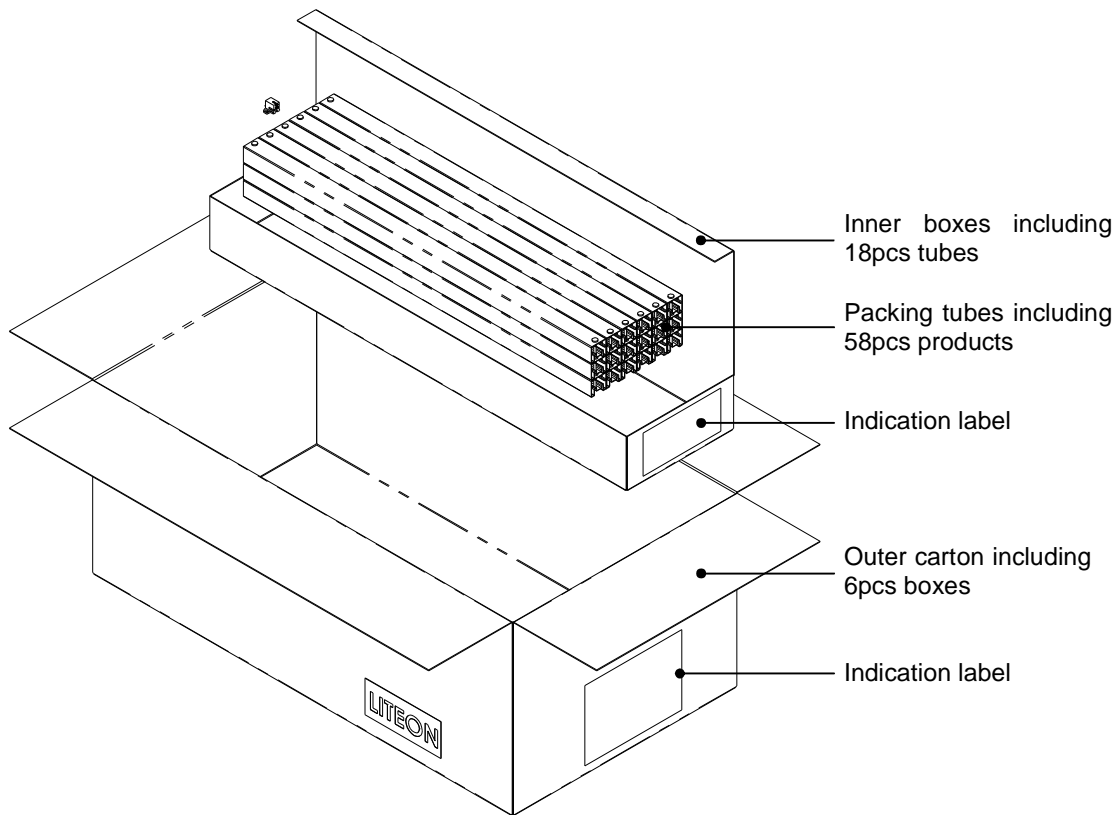

5.2 Packing dimension

Outer Carton: 66.5 x 35.5 x 26.5 cm

Inner Box: 66 x 17 x 7.5 cm