



## Film capacitors – Capacitors for Power Factor Correction

### Key components

Multi-measuring interface MMI6000 for BR6000 controller

**Series/Type:** MMI6000  
**Ordering code:** B44066M6...E230  
Date: September 2007  
Version: 1

**Characteristics**

- Measuring device for electrical (real current) measurement
- Additional protection for PFC systems
- Two in one:
  - Accessory for PF-controller BR6000 series
  - Stand-alone measuring device
- Illuminated graphical display
- Small dimensions

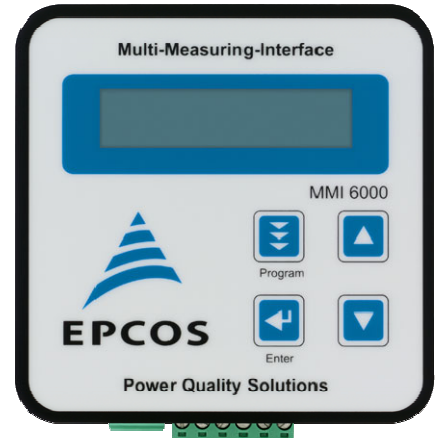

**Technical data and specifications**

Types/Output	MMI6000-R (1 standard relay) MMI6000-T (1 optocoupler)
Interface	RS485
Display	Graphical, 2 × 16 characters
Supply and measurement voltage	230 V, 50/60 Hz
Power consumption	< 4 VA
Measurement current	X/5 A and X/1 A
Output capacity	Standard relay: 250 V AC, 1000 W Optocoupler: 60 V DC, 150 mA
Measuring temperature range	0 ... 100 °C
Ambient temperature range	-10 ... +55 °C
Housing	Switchboard installation housing, DIN 43 700
Dimensions	100 × 100 × 50 mm
Weight	0.5 kg
Protection category to DIN 40 050	Front side: IP54 Rear side: IP20

Operation modes	Coupling MMI6000 – BR6000 Coupling MMI6000 – BR6000T DYNA-I-TRIGGER MMI – MODBUS RTU MMI – ASCII OUT
Measurement categories	Voltage, current Power factor Active power Reactive power Apparent power Frequency Temperature Energy
Languages	German and English
Ordering Codes	
MMI6000-R	B44066M6000E230
MMI6000-T	B44066M6100E230

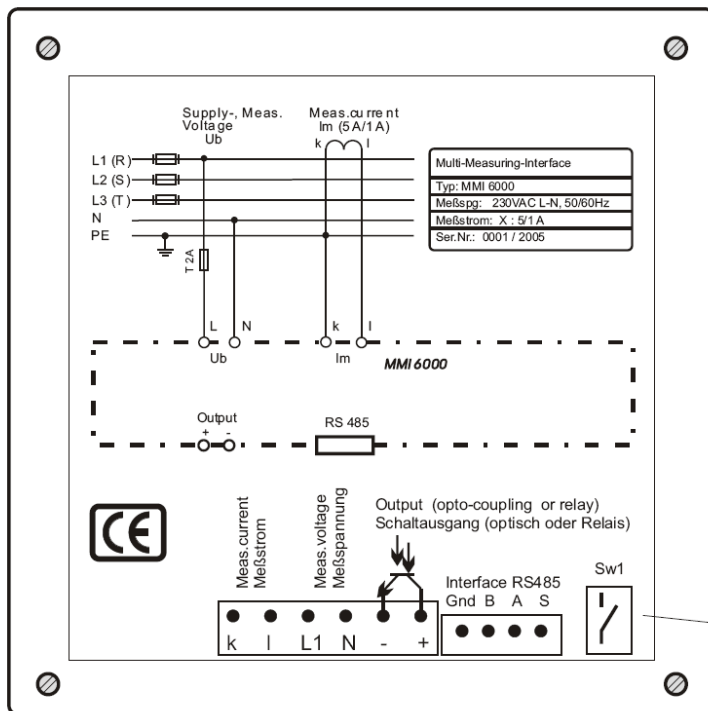

Back side MMI 6000

Connection of MMI 6000 according to adjoining connection diagram

Switch for terminating resistor

## Cautions and warnings

### General

- The MMI 6000 may only be used for the purpose it has been designed for.
- The device has to be projected in such a way that in case of any failure no uncontrolled high current and voltages may occur.
- The device in operation has to be protected against moisture and dust, sufficient cooling has to be assured.
- Please note that the device is under high tension during operation.
- The MMI 6000 may only be used indoor. It is not suitable for outdoor applications.
- Voltages above the permitted voltage range may damage the device.

### Attention

FAILURE TO FOLLOW CAUTIONS MAY RESULT, WORST CASE, IN PREMATURE FAILURES OR PHYSICAL INJURY.

### Note

For detailed information about PFC capacitors and cautions, refer to the latest version of the EPCOS PFC Product Profile.

**⚠** Please read cautions information about PFC capacitors and cautions as well as installation and maintenance instructions in the actual version of the Product Profile *Power Factor Correction* to ensure optimum performance and prevent products from failing, and in worst case, bursting and fire, etc. The actual Product Profile is available at [www.epcos.com/publications](http://www.epcos.com/publications).

Information given in the PFC-product profile and values given in the data sheet reflect typical specifications. You are kindly requested to approve our product specifications or request our approval for your specification before ordering.

## Important notes

The following applies to all products named in this publication:

1. Some parts of this publication contain **statements about the suitability of our products for certain areas of application**. These statements are based on our knowledge of typical requirements that are often placed on our products in the areas of application concerned. We nevertheless expressly point out **that such statements cannot be regarded as binding statements about the suitability of our products for a particular customer application**. As a rule, EPCOS is either unfamiliar with individual customer applications or less familiar with them than the customers themselves. For these reasons, it is always ultimately incumbent on the customer to check and decide whether an EPCOS product with the properties described in the product specification is suitable for use in a particular customer application.
2. We also point out that **in individual cases, a malfunction of passive electronic components or failure before the end of their usual service life cannot be completely ruled out in the current state of the art, even if they are operated as specified**. In customer applications requiring a very high level of operational safety and especially in customer applications in which the malfunction or failure of a passive electronic component could endanger human life or health (e.g. in accident prevention or life-saving systems), it must therefore be ensured by means of suitable design of the customer application or other action taken by the customer (e.g. installation of protective circuitry or redundancy) that no injury or damage is sustained by third parties in the event of malfunction or failure of a passive electronic component.
3. **The warnings, cautions and product-specific notes must be observed.**
4. In order to satisfy certain technical requirements, **some of the products described in this publication may contain substances subject to restrictions in certain jurisdictions (e.g. because they are classed as “hazardous”)**. Useful information on this will be found in our Material Data Sheets on the Internet ([www.epcos.com/material](http://www.epcos.com/material)). Should you have any more detailed questions, please contact our sales offices.
5. We constantly strive to improve our products. Consequently, **the products described in this publication may change from time to time**. The same is true of the corresponding product specifications. Please check therefore to what extent product descriptions and specifications contained in this publication are still applicable before or when you place an order.

We also **reserve the right to discontinue production and delivery of products**. Consequently, we cannot guarantee that all products named in this publication will always be available.

6. Unless otherwise agreed in individual contracts, **all orders are subject to the current version of the “General Terms of Delivery for Products and Services in the Electrical Industry” published by the German Electrical and Electronics Industry Association (ZVEI)**.
7. The trade names EPCOS, BAOKE, Alu-X, CeraDiode, CSSP, MiniBlue, MKK, MLSC, MotorCap, PCC, PhaseCap, PhaseMod, SIFERRIT, SIFI, SIKOREL, SilverCap, SIMDAD, SIMID, SineFormer, SIOV, SIP5D, SIP5K, ThermoFuse, WindCap are **trademarks registered or pending** in Europe and in other countries. Further information will be found on the Internet at [www.epcos.com/trademarks](http://www.epcos.com/trademarks).