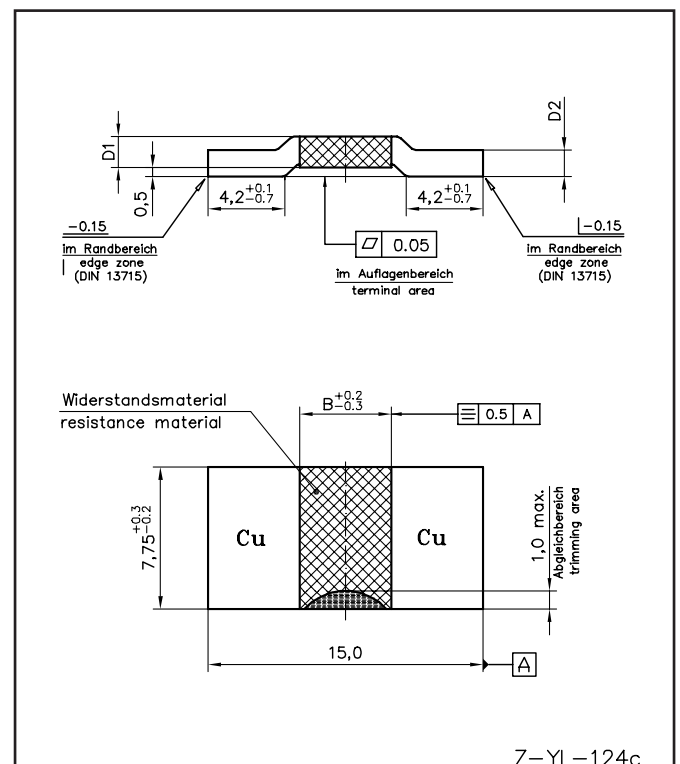
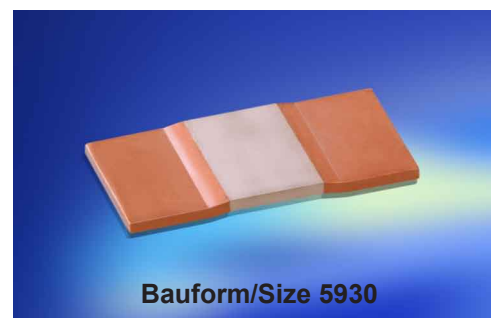

ISA-WELD® - SMD Präzisionswiderstände / SMD precision resistors

TECHNISCHE DATEN / TECHNICAL DATA		
Widerstandswerte (mOhm)	Resistance values (mOhm)	0.2, 0.3, 0.5, 1 mOhm
Toleranz	Tolerance	1 %, 2 %, 5 %
Temperaturkoeffizient	Temperature coefficient (tcr)	< 50 ppm/K (20 °C to 60 °C)
Temperaturbereich	Applicable temperature range	-55 °C to +170 °C
Belastbarkeit	Load capacity	5 W
Innerer Widerstand (R_{thi})	Internal heat resistance (R_{thi})	< 10 K/W
Induktivität	Inductance	< 3 nH
Stabilität (Nennlast) Abweichung T_K = Kontaktstellentemperatur Stability (nominal load) deviation T_K = Terminal temperature		< 0.5 % nach/after 2000 h (T_K = 85°C) < 1.0 % nach/after 2000 h (T_K = 120°C)

MERKMALE / FEATURES

- 5 Watt Dauerleistung
- 5 Watt permanent power
- Dauerströme bis 160 A (0.2 mOhm)
- Continuous current load up to 160 Amps (0.2 mOhm)
- Massive Kupferanschlüsse
- Heavy copper connectors
- Sehr gute Langzeitstabilität
- Excellent long term stability
- Ideal geeignet für die Montage auf DCB Keramik/IMS Substrat
- Ideal suited for mounting on DBC / IMS substrate
- Geeignet für Löttemperaturen bis 350 °C / 30 sek
- Max. solder temperature up to 350 °C / 30 sec

APPLIKATIONEN / APPLICATION

- Messwiderstand für Leistungshybride
- Current sensor for power hybrid applications
- Für Schweißmontage an Stromschienen
- For welding on bus bars
- Hochstromanwendungen in der Automobiltechnik
- High current applications for the automotive market
- Frequenzumrichter
- Frequency converters
- Leistungsmodule
- Power modules

Typ	Wert	Material	Dicke (D1)
Type	Value	Material	Thickness (D1)
BVE-M-R0002	0.2 mOhm	MANGANIN®	1.42 mm
BVE-M-R0003	0.3 mOhm	MANGANIN®	0.94 mm
BVE-M-R0005	0.5 mOhm	MANGANIN®	0.56 mm
BVE-A-R0005	0.5 mOhm	Aluchrom	1.63 mm
BVE-A-R001	1.0 mOhm	Aluchrom	0.91 mm

TK, Lastminderung und Langzeitstabilität / TCR, power derating and long term stability

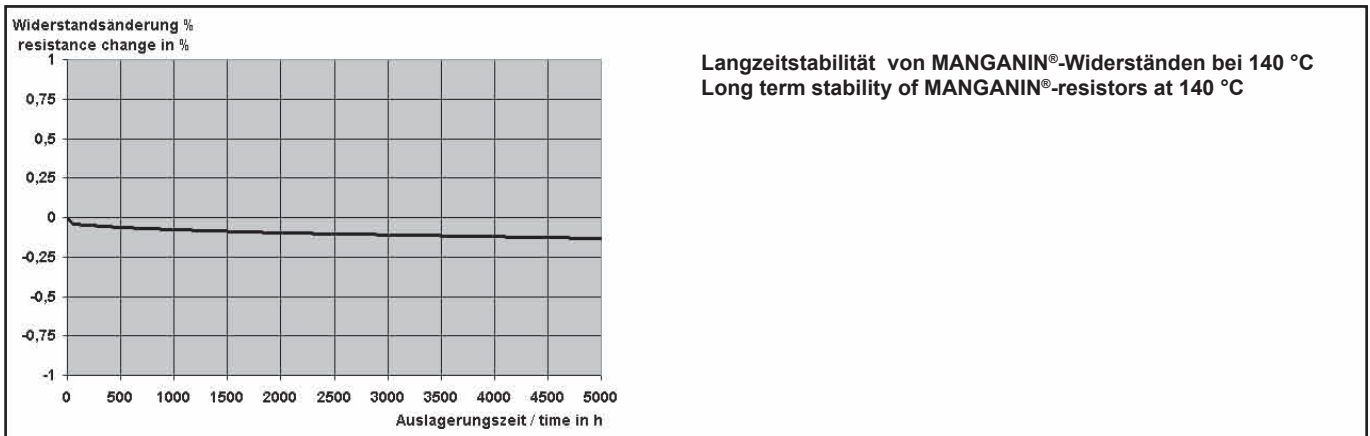
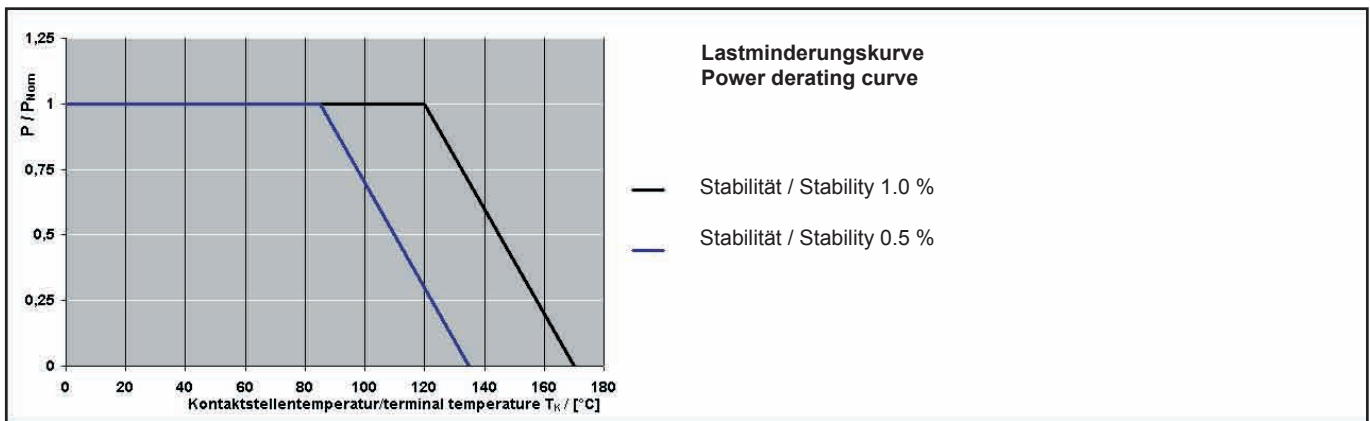
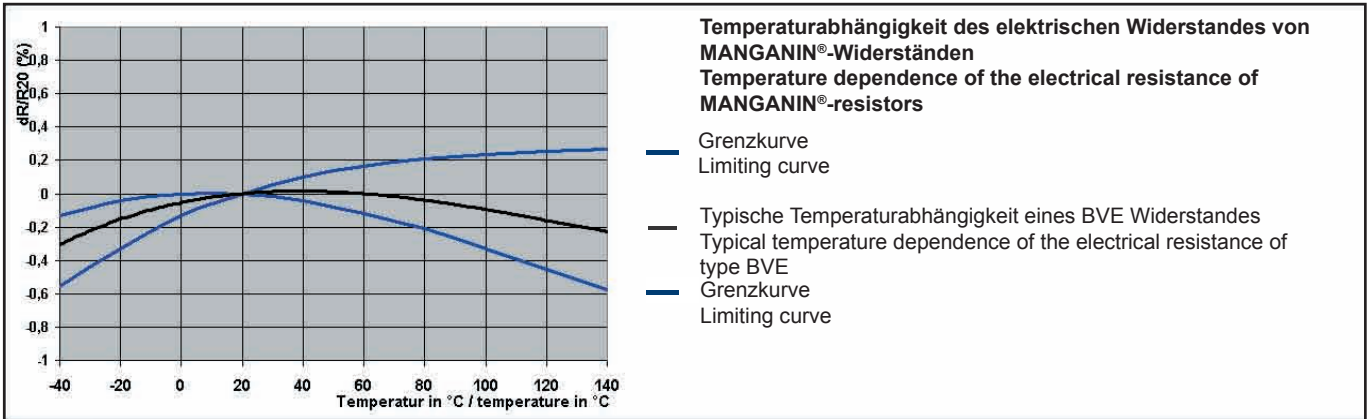

Vorschlag für Leiterplatten Layout (Reflowlöten)
Proposal for pcb-layout (reflow soldering)

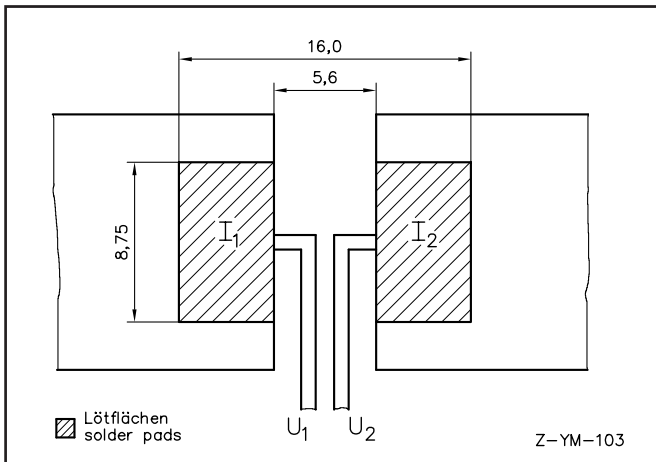

Lötprofil Vorschlag / Recommended solder profile			
Reflow-, IR-löten			
Reflow, infrared soldering			
Temperatur	260 °C	255 °C	217 °C
Zeit (s)	Peak	40	90
<p>RoHS 2002/95/EG konform seit Produktstart. Ausführliche Informationen erhalten Sie auf unserer Homepage: www.isabellenhuette.de</p> <p>RoHS 2002/95/EC compliance since product launch. For more information please visit our website: www.isabellenhuette.de</p>			

GURTINFORMATIONEN / TAPE & REEL INFORMATION	
Norm / Specification	DIN EN 60286-3
Gurtbreite / Tape width	24 mm
Anzahl Bauteile/Parts per reel	2000 Stk. / pcs

BESTELLBEZEICHNUNG / ORDERING CODE			
BVE-M-R0005-1.0			
Typ	Material	Widerstandswert	Toleranz
Type	Material	Resistance value	Tolerance
BVE	MANGANIN®	0.5 mOhm	1.0 %

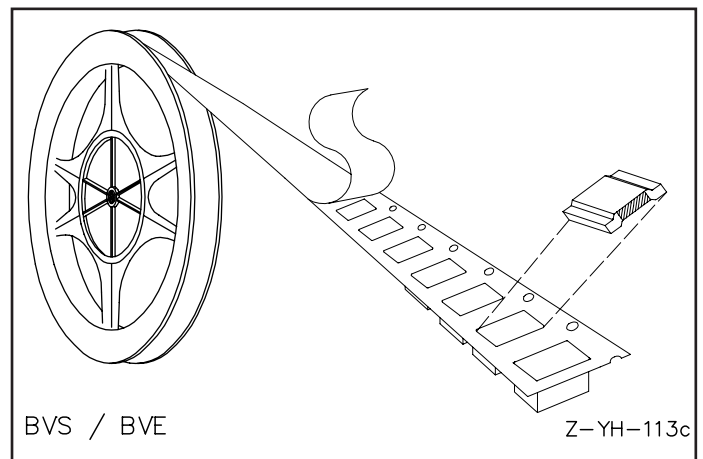

Gewährleistung

Alle Angaben über Eignung, Verarbeitung und Anwendung unserer Produkte, technische Beratung und sonstige Angaben erfolgen nach bestem Wissen, befreien den Käufer jedoch nicht von eigenen Prüfungen und Versuchen.

Warranty

All information regarding the suitable, workability and applicability of our products, all technical advice and other information are provided to the best of our knowledge and belief, but shall not discharge the buyer from his own examinations and tests.



Grenzkurve für maximale Pulsenergie bzw. Pulsleistung für Dauerbetrieb
Maximum puls energy resp. pulse power for continous operation

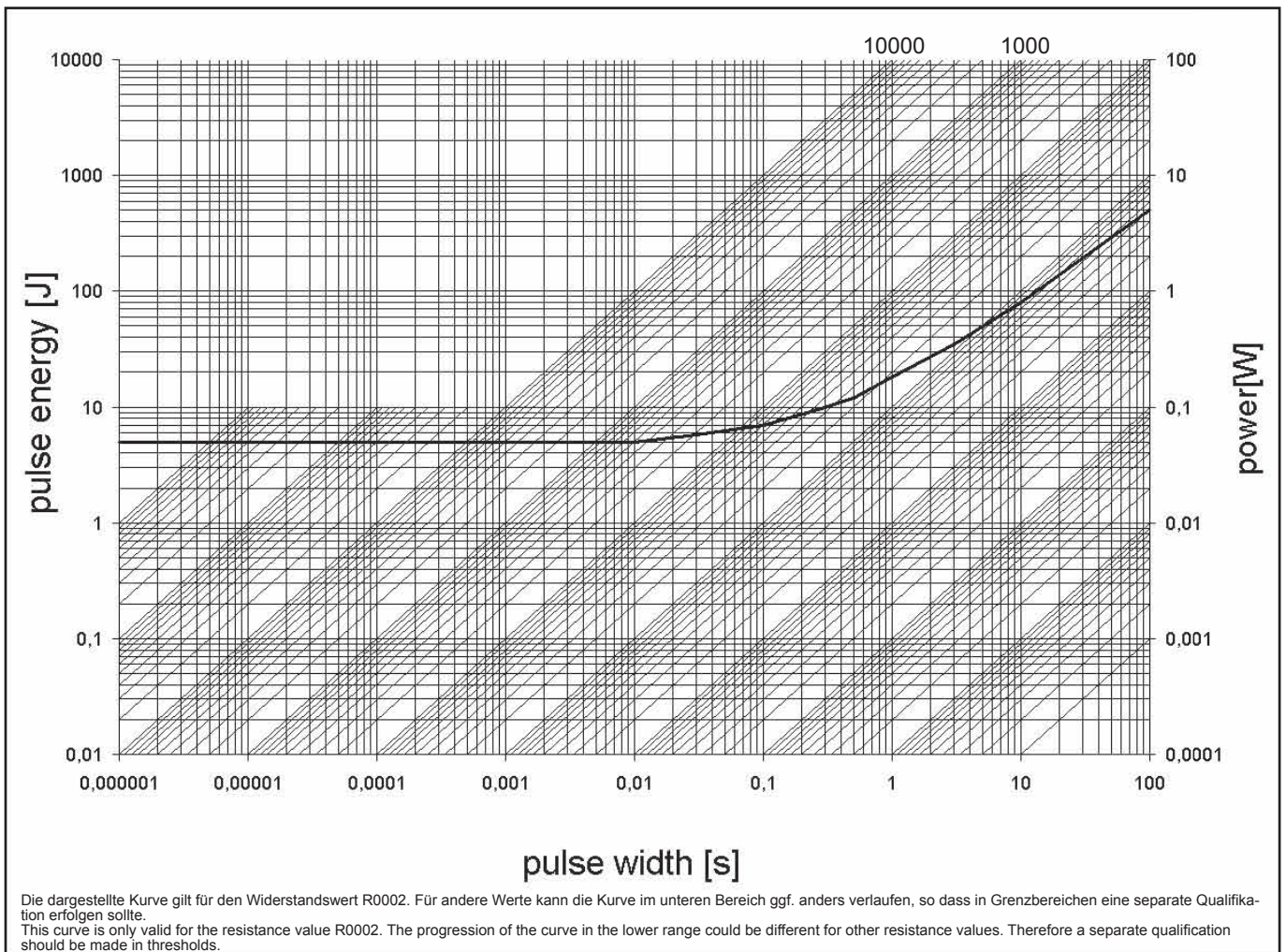

MIL. - STANDARD		
Parameters	Test Conditions	Specification
Maximum Temperature for full power operation	120 °C	120 °C
Working Temperature	-55 to 170 °C	-55 to 170 °C
Thermal Shock	MIL-STD-202 method 107E-B1	0.1 %
Overload	MIL-R-26E (5 times rated power, 5 sec)	0.2 %
Solderability	MIL-STD-202 method 208	> 95 % coverage
Resistance to Solvents	MIL-STD-202 method 215A, 2.1a, 2.1d	no damage
Low Temperature Storage and Operation	MIL-STD-26E	0.1 %
Resistance to Soldering Heat	MIL-STD-202 method 210B	0.1 %
Moisture Resistance	MIL-STD-202 method 106	0.1 %
Shock	MIL-STD-202 method 213B-A	0.2 %
Vibration, High Frequency	MIL-STD-202 method 204D-B	0.2 %
Life	MIL-STD-26E	0.2 %
Storage Life at Elevated Temperature	MIL-STD-202 method 108A-F	0.3 %
High Temperature Exposure	140 °C, 2000 h	0.2%
Current Noise	MIL-STD-202 method 308	0.01 %
Voltage Coefficient (%/V)	MIL-STD-202 method 309	linearity error less than 120dB
Resistance Temperature Characteristic	MIL-STD-202 method 304 (20-60°C)	< 50 ppm/K
Thermal EMF	0 - 100 °C	2 µV/ °C max.
Frequency Characteristic	inductivity	< 3 nH