



## INSTALLATION INSTRUCTIONS

# ADJUSTABLE FLANGE DISTRIBUTOR ADJUSTMENT PROCEDURE TYPE 482, 590, 790 AND 791 DISTRIBUTORS

### GENERAL INFORMATION

Adjustable flange distributors allow you to raise or lower the distributor by moving the flange down or up the distributor shank so that the distributor drive gear engages properly with the camshaft gear. Adjustment is necessary anytime the engine block deck height is changed, cylinder heads have been machined or offset, or any intake manifold modifications.

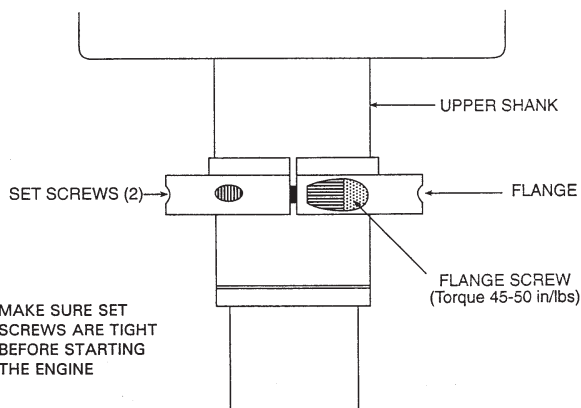

Types 482, 590, 790 and 791 mentioned in this writing are derived from the particular distributor's part number (example: 3448205; 3479005). Type 482's shallow groove on the upper shank of the distributor is the stock flange height reference for 265-454 Chevrolet engines (figure 1). Type 790's and 791's have two shallow grooves. The lower shallow groove on the upper shank of the distributor is the stock flange height reference for Chevrolet V8 265-454 engines. The upper groove on the upper shank of the distributor is the stock flange height reference for Chevrolet V8 Tall/Truck Block engines (figure 2).

Align the bottom of the flange with the shallow groove and tighten the flange screw to position the flange at a stock flange height reference. Tighten the set screws.

#### Step 1

Disconnect your ignition system. Turn the engine crankshaft in the direction of rotation until the timing

**FIGURE 1**

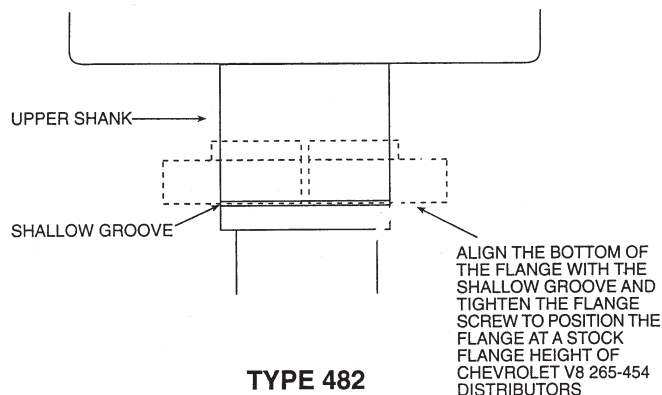

mark lines up with the top dead center (TDC) mark on the timing tab and #1 cylinder is on its compression stroke.

**NOTE: Removing the spark plugs may make it easier to turn the crankshaft.**

#### Step 2

Remove the distributor cap.

#### Step 3

Loosen the flange and set screws. Slide the flange up the upper shank.

**FIGURE 2**

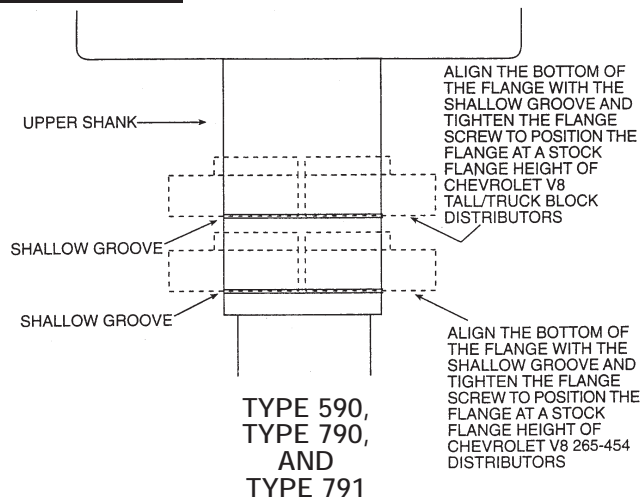

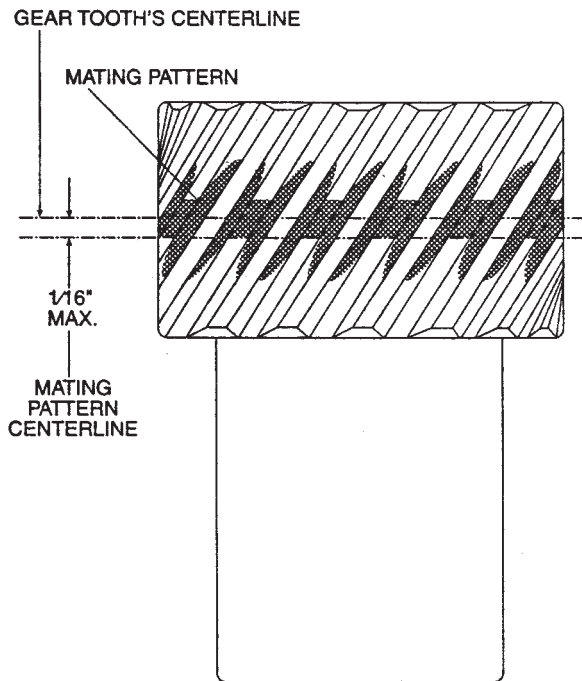
**FIGURE 3****Step 4**

Place the distributor in the engine with the rotor pointing in the same general direction as the original distributor. It is not necessary to have the distributor gasket in place at this time.

**NOTE:** *The distributor shaft tongue must be fully engaged into the oil pump drive. It may be necessary to turn the oil pump drive, or turn the engine crankshaft in the direction of rotation two full turns until the timing mark lines up (again) with the TDC mark on the timing tab, to allow the distributor shaft tongue to fully engage into the oil pump drive.*

**Step 5**

Lift the distributor 0.010-0.030". Slide the flange down to rest on the intake manifold. Tighten the flange screw. Remove the distributor from the engine.

**Step 6**

Coat the teeth of the distributor drive gear with gear marking compound (White Lead; High Spot Blue™; Prussian Blue™). Camshaft/moly lube may be used instead of gear marking compound.

**Step 7**

Put the distributor gasket in place (if one is used). Place the distributor in the engine with the rotor pointing in the same general direction as the original distributor. Put the distributor hold down clamp in place and tighten slightly.

**Step 8**

Turn the engine crankshaft in the direction of rotation two full turns until the timing mark lines up (again) with the TDC mark on the timing tab. Remove the distributor hold down clamp and remove the distributor from the engine.

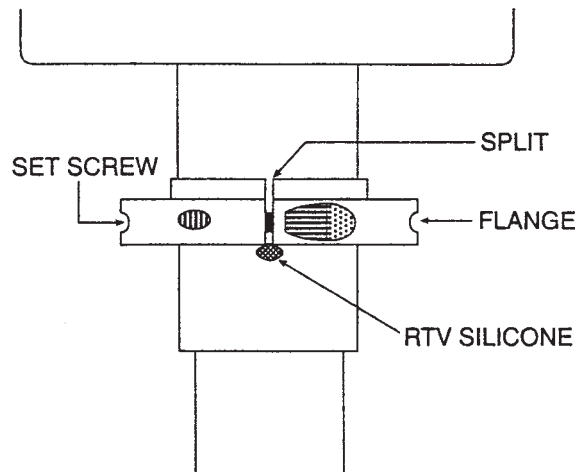
**FIGURE 4****Step 9**

Check the mating pattern on the distributor drive gear. The mating pattern centerline must be within 1/16" (0.0625") of the gear tooth's centerline (figure 3).

**Step 10**

If the mating pattern centerline is above the gear tooth's centerline or more than 1/16" below the gear tooth's centerline, loosen the flange screw, move the flange, tighten the flange screw and repeat steps 6-9.

**Step 11**

Clean off the gear marking compound on the distributor drive gear. Tighten the set screws. Put a small amount of RTV silicone on the bottom of the flange at the split (figure 4) to prevent oil and vapors (blow-by) from leaking. Proceed to the distributor instructions.



MALLORY IS A DIVISION OF THE MR. GASKET PERFORMANCE GROUP  
550 MALLORY WAY, CARSON CITY, NEVADA 89701  
(775) 882-6600 FAX (775) 887-4377  
www.mrgasket.com

FORM 1316  
(REV. C) 06/03  
Made in U.S.A.  
Printed in U.S.A.