

PLEASE CHECK WWW.MOLEX.COM FOR LATEST PART INFORMATION

Part Number: [0002065130](#)
Status: **Active**
Overview: [standard_062](#)
Description: 1.57mm (.062") Diameter, Standard .062" Pin and Socket Crimp Terminal, Series 1855, Female, with 0.38µm (15µ") Gold (Au) Plated Brass Contact, 24-30 AWG, Reel

Documents:

[Drawing \(PDF\)](#) [RoHS Certificate of Compliance \(PDF\)](#)

General

Product Family	Crimp Terminals
Series	1855
Crimp Quality Equipment	Yes
Overview	standard_062
Product Name	Standard .062"

Physical

Gender	Female
Material - Metal	Brass
Material - Plating Mating	Gold
Material - Plating Termination	Nickel
Packaging Type	Reel
Plating min: Mating (µin)	15
Plating min: Mating (µm)	0.38
Plating min: Termination (µin)	30
Plating min: Termination (µm)	0.76
Termination Interface: Style	Crimp or Compression
Wire Insulation Diameter	1.02-2.29mm (.040-.090")
Wire Size AWG	24, 26, 28, 30
Wire Size mm ²	N/A

Material Info

Old Part Number	1855P550
-----------------	----------

Reference - Drawing Numbers

Sales Drawing	SD-1855-*
---------------	-----------

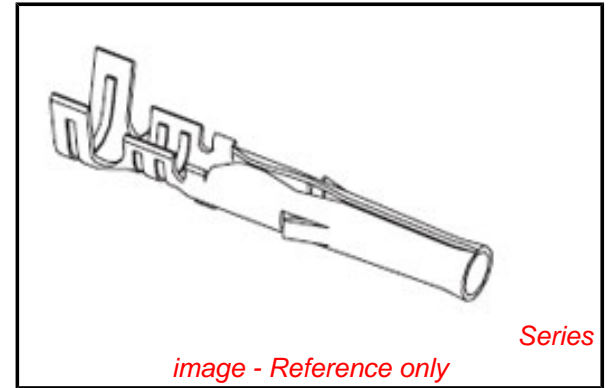

EU RoHS

ELV and RoHS Compliant
REACH SVHC
Contains SVHC: No
Halogen-Free Status

China RoHS



Need more information on product environmental compliance?

Email productcompliance@molex.com
 For a multiple part number RoHS Certificate of Compliance, [click here](#)

Please visit the [Contact Us](#) section for any non-product compliance questions.

Search Parts in this Series

[1855Series](#)

Application Tooling | [FAQ](#)

Tooling specifications and manuals are found by selecting the products below. Crimp Height Specifications are then contained in the Application Tooling Specification document.

Global

Description	Product #
Mini-Mac™ Applicator	0638914100
Hand Crimp Tool	0638190800
Manual Extraction Tool	0011030002
Terminator Die	0011402006
Hand Crimper - DISTRIBUTION ONLY	0638111000

Japan

Description	Product #
Hand Insertion Tool	0011020001

This document was generated on 05/17/2010

PLEASE CHECK WWW.MOLEX.COM FOR LATEST PART INFORMATION

PART NO.	ENG. NO.	
02-06-1131	1855-(P901)	
02-06-1132	1855-(P901)IL	
02-06-5137	1855-(P591)	OBSOLETE
02-06-5136	1855-(P591)IL	OBSOLETE
02-06-5138	1855-(P561)	
02-06-5139	1855-(P561)IL	
02-06-5130	1855-(P550)	
02-06-5135	1855-(P550)IL	
02-06-5147	1855-(P228)	
02-06-5148	1855-(P228)IL	
02-06-1141	1855-1(P901)	
NOT TOOLED	1855-1(P901)IL	
02-06-1143	1855-(P901)11	

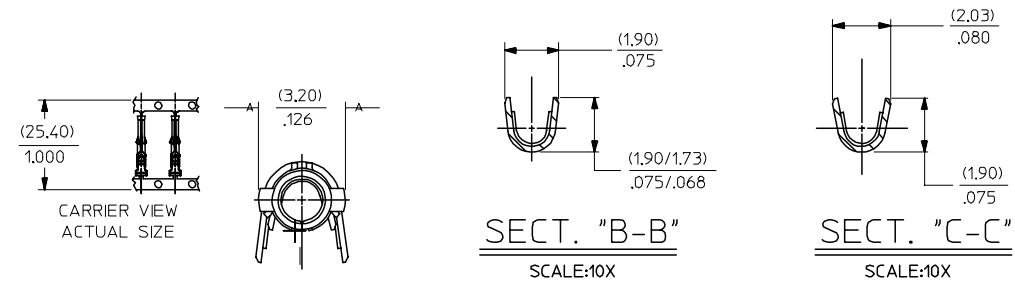

LEGEND

1855-*(****)*

BLANK=WITH LOCKING TABS
1=WITHOUT LOCKING TABS

P=PREPLATE
BLANK=POSTPLATE

FORM
BLANK=CHAIN
1=CHAIN WITH INTERLEAF
PAPER ON REEL.
L=LOOSE

FINISH CODE

NOTES:

- MATERIAL: BRASS
- FINISHES:
 - 901 HOT TIN DIP (.00051)/.000020 MIN.
 - * 228 SELECT GOLD PLATE (.00075)/.000030 MIN. IN CONTACT AREA, SELECT TIN (.00250)/.000100 MIN. IN CRIMP AREA OVER (.00125)/.000050 MIN. NICKEL OVERALL, WITH .000010/(0.00025) MAX. SELECT GOLD FLASH IN AREA INDICATED.
 - 561 SELECT GOLD PLATE (.00076)/.000030 MIN. IN CONTACT AREA, (.00127)/.000050 MIN. NICKEL OVERALL.
 - 591 SELECT GOLD PLATE (.00127)/.000050 MIN. IN CONTACT AREA, OVER (.00127)/.000050 MIN. NICKEL OVERALL WITH (.00025)/.000010 MAX. GOLD FLASH OVERALL.
 - 550 SELECT GOLD PLATE (.00038)/.000015 MIN. IN CONTACT AREA, OVER (.00076)/.000030 MIN. NICKLE OVERALL WITH (.00025)/.000010 MAX. GOLD FLASH OVERALL.
- THE PRIMARY SHIPPING CARTON WILL BE LABELED, *COMPLIANT TO RoHS DIRECTIVE 2002/95/EC AND ELV ANNEX II OF DIRECTIVE 2000/53/EC THIS LABEL MAY CONTAIN PRODUCT WITH TIN-LEAD.
- PRODUCT SPECIFICATION: PS-02-0-6
- PACKAGE INFORMATION: NOT AVAILABLE
- TERMINAL FOR USE WITH (1.57)/.062 DIA. SERIES HOUSINGS AND WILL ACCEPT 24 THRU 30 AWG WIRE WITH (1.02/2.29)/.040/.090 INSULATION DIAMETER.

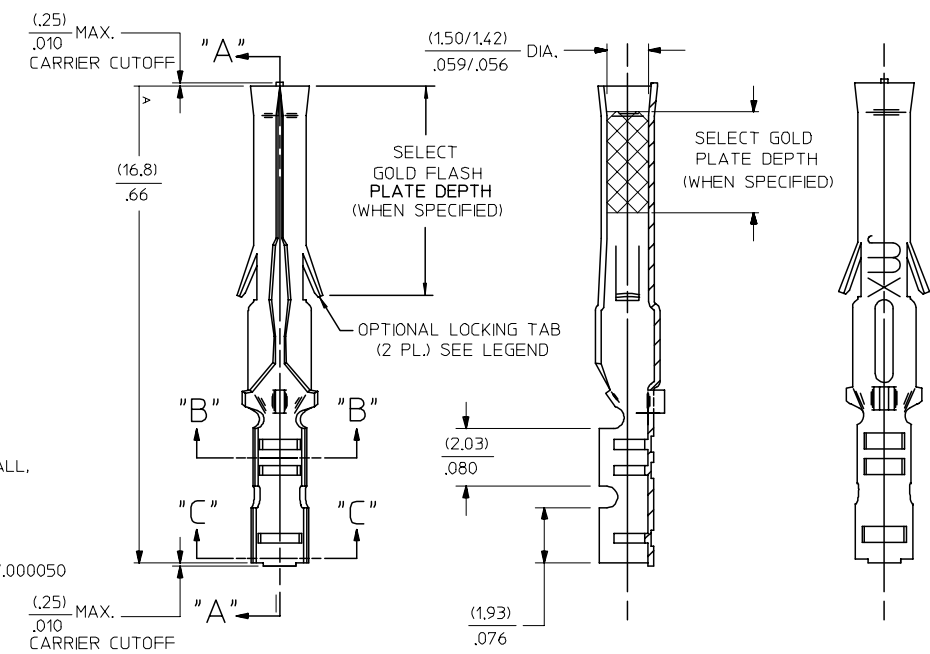

AP	REVISE Sn/Pb PLATE REDRAWN TO ME10 UCR2004-2097 5/07/04 RHOLTS
AN	OBSOLETE P/N UCR2002-0270 COMERCI 01/9/28
AM1	OBSOLETE -P575J & -P575AL ECR UG 0558 GC3/15/95 RW
AM	REV. AND REDRAWN PER ECR 10372 GEP 6-17-87 RW

REV. MATL. SPEC/STAT TO ME10 EC NO: UICP2004-2097 DRAWN/RHOLTS 2004/05/14 CHKD: 2004/05/14 APPR: F SMITH 2004/05/18	QUALITY SYMBOLS ▽=0 ▽=0	GENERAL TOLERANCES (UNLESS SPECIFIED)		SCALE 8:1	DESIGN UNITS INCH	THIRD ANGLE PROJECTION	REVISE ON CAD ONLY		
		mm	INCH	DIMENSION STYLE IN/MM	TITLE		MATERIAL NO.		DOCUMENT NO.
AP	▽=0	4 PLACES ± .005	± .005	DRAWN BY GEP	DATE 1987/09/17	MATERIAL NO. SEE CHART	DOCUMENT NO. SD-1855-*	SHEET NO. 1 OF 1	THIS DRAWING CONTAINS INFORMATION THAT IS PROPRIETARY TO MOLEX INCORPORATED AND SHOULD NOT BE USED WITHOUT WRITTEN PERMISSION
		3 PLACES ± .005	± .01						
		2 PLACES ± 0.25	± .014	CHECKED BY RW	DATE 1987/09/17				
		1 PLACE ± 0.35	± .05	APPROVED BY RAS		DATE 1987/09/17			
		ANGULAR ±1/2°		DRAFT WHERE APPLICABLE MUST REMAIN WITHIN DIMENSIONS					