

SP20/SP20F SERIES

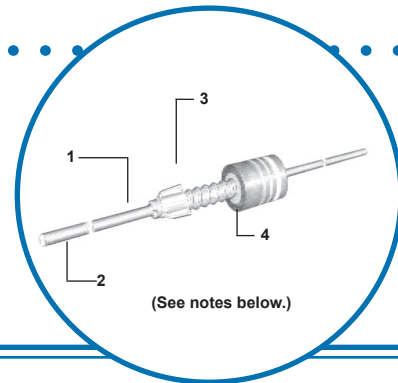

GENERAL-PURPOSE FAILSAFE MOLDED WIREWOUND RESISTOR

- SP20F is Fusible and has flame resistant coating
- Drop-in replacement for BW20/BW20F
- 1 watt rated with 1/2 watt dimensions
- $\pm 5\%$, $\pm 10\%$ tolerance
- 0.1 ohm to 1200 ohms
- TCR's as low as ± 150 ppm/ $^{\circ}\text{C}$ standard (custom TC's available)
- Weldable and solderable magnetic leads
- Lead-free, ROHS Compliant Construction Available



SPECIFICATIONS:

IRC Type		SP20	SP20F
EIA RS-344 Style		CRU 1	CRU 1
Resistance - Std.		0.1 Ω to 1200 Ω	0.1 Ω to 1000 Ω
Tolerance - Std.		$\pm 5\%$, $\pm 10\%$	$\pm 5\%$, $\pm 10\%$
Power Rating		1 watt @ 50 $^{\circ}\text{C}$ 3/4 watt @ 70 $^{\circ}\text{C}$ 1/2 watt @ 100 $^{\circ}\text{C}$ Derating to 0 @ 160 $^{\circ}\text{C}$	1 watt @ 50 $^{\circ}\text{C}$ 3/4 watt @ 70 $^{\circ}\text{C}$ --- Derating to 0 @ 160 $^{\circ}\text{C}$
Max. Continuous Working Voltage		$\sqrt{\text{PR}}$	$\sqrt{\text{PR}}$
Min. Insulation Resistance	Dry	10,000 Meg	10,000 Meg
	Wet	100 Meg	100 Meg
Min. Dielectric Withstanding Volts(RMS)	ATM	700 V	700 V
	Reduced Pressure	450V	450 V
Hotspot Temperature Rise		120 $^{\circ}\text{C}$ @ 1 watts	120 $^{\circ}\text{C}$ @ 1 watts
Typical Load Life		5%	5%
Current Noise		Negligible	Negligible

1. Resistive Element

All resistor types have resistance alloy winding on a braided fiberglass substrate. Intermediate silicone coatings are used to enhance processibility and to provide protection to the resistive element.

2. Termination

The SP-20 and SP-20F resistors are terminated using an alloy coated copper flashed steel lead welded to a cap of the same material. This termination assembly is mechanically crimped, utilizing an improved crimp design, to the resistive element.

3. Encapsulation

The SP-20 and SP-20F are encapsulated utilizing a compression molded phenolic plastic material. The SP-20F has a flame-resistance coating applied over the resistive element to provide flammability protection when destructive overloads may occur.

4. Marking

All products are marked utilizing heat and solvent resistant color code bands consistent with EIA/MIL requirements. The first band is double width to des-

DIMENSIONS (Inches and (mm)):

IRC TYPE	A	B	C	D
SP20	0.390 \pm 0.010 (9.91 \pm 0.25)	0.140 \pm 0.008 (3.56 \pm 0.20)	0.032 \pm 0.002 (0.813 \pm 0.05)	1.50 \pm 0.126 (38.1 \pm 3.2)
SP20F	0.390 \pm 0.010 (9.91 \pm 0.25)	0.140 \pm 0.008 (3.56 \pm 0.20)	0.032 \pm 0.002 (0.813 \pm 0.05)	1.50 \pm 0.126 (38.1 \pm 3.2)

*Unless otherwise specified, standard test centers are 1 3/4 inches.

General Note

IRC reserves the right to make changes in product specification without notice or liability. All information is subject to IRC's own data and is considered accurate at time of going to print.

WIREWOUND AND FILM TECHNOLOGIES DIVISION

736 Greenway Road • Boone, North Carolina 28607-1860 • Tel: 828-264-8861 • Fax: 828-264-8866 • www.irctt.com



A subsidiary of TT electronics
1005

SP20/SP20F CHARACTERISTICS (TYPICAL PERFORMANCE):

Test	SP20	SP20F
Temperature Coefficient (ppm) *	<1R <±800 ≥1R <±150	<1R <±800* ≥1R <±150
Dielectric Withstanding Voltage (RMS)	700V	700V
Momentary Overload	5%	5%
Low Temperature Operation	5%	5%
Temperature Cycle	5%	5%
Humidity	5%	5%
Load Life	5%	5%
Terminal Strength	5%	5%
Resistance to Solder Heat	5%	5%
Solderability	No Failures	No Failures

*0.1 ohm SP20F <1000 ppm.

SP-20 POWER DERATING:

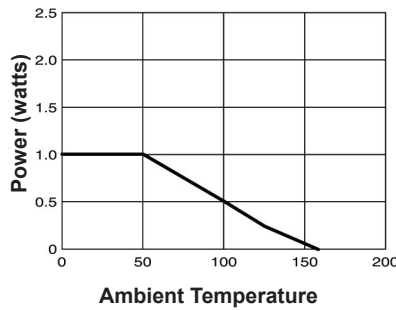

SP-20F POWER DERATING:

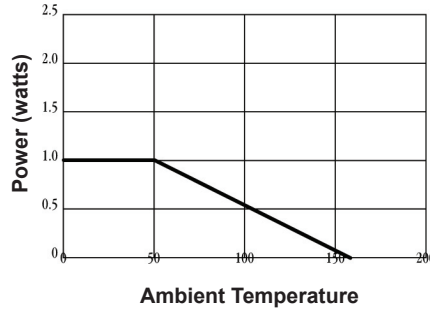

SP-20F TYPICAL FUSING:

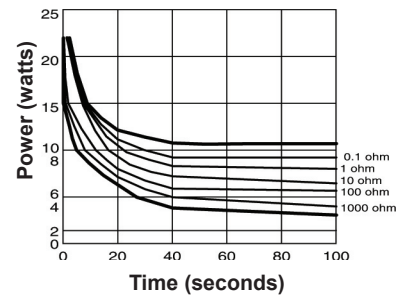

SP-20 AND SP-20F TEMPERATURE RISE:

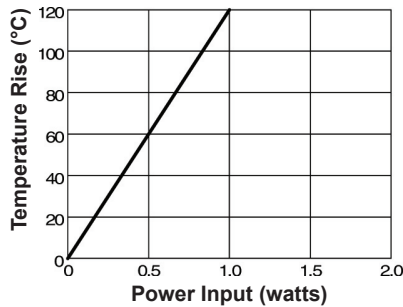

HOW TO ORDER:

Sample Part No.:

