

# M24758/8 Conduit-to-Conduit Fitting

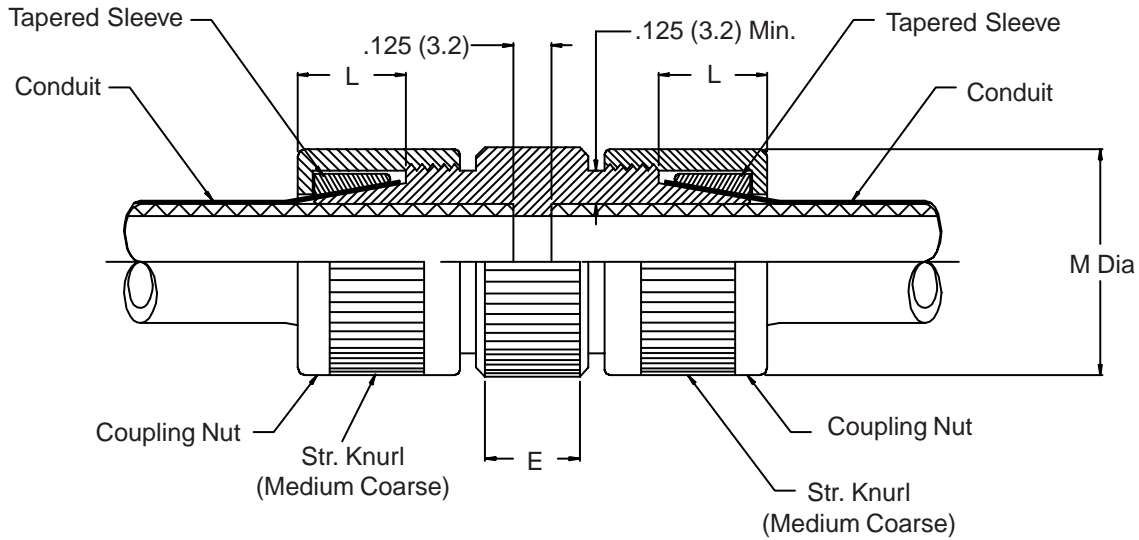

## M24758/8-16-A

Basic Part No. ————  
 Conduit Size Code ————  
 Material Designator:  
 A = Aluminum  
 B = Brass  
 C = CRES 316



**TABLE I**

Conduit Size Code	E Knurl Length ±.06 (15.2)	L Cone Length ±.06 (15.2)	M Dia (Maximum)
02	.500 (12.7)	.750 (19.1)	.930 (23.6)
03	.500 (12.7)	.750 (19.1)	1.120 (28.4)
04	.560 (14.2)	.750 (19.1)	1.250 (31.8)
05	.560 (14.2)	.750 (19.1)	1.430 (36.3)
06	.620 (15.7)	.750 (19.1)	1.620 (41.1)
08	.620 (15.7)	1.000 (25.4)	1.810 (46.0)
10	.680 (17.3)	1.000 (25.4)	2.180 (55.4)
12	.680 (17.3)	1.000 (25.4)	2.560 (65.0)
16	.750 (19.1)	1.000 (25.4)	3.060 (77.7)
20	.750 (19.1)	1.000 (25.4)	3.680 (93.5)
24	.750 (19.1)	1.000 (25.4)	4.380 (111.3)

1. The function of the M24758/8 conduit-to-conduit fitting is to connect two sections of flexible shielding conduit. Consult factory to mate two different sizes of conduit.
2. Metric dimensions (mm) are indicated in parentheses.
3. For complete dimensions see applicable Military Specification.