

PLEASE CHECK WWW.MOLEX.COM FOR LATEST PART INFORMATION

Part Number: [0885309300](#)
Status: **Active**
Overview: [fiber optic product families](#)
Description: SMI Loopback Looping

Documents:

[Drawing \(PDF\)](#) [RoHS Certificate of Compliance \(PDF\)](#)

General

| | |
|------------------------|--|
| Product Family | Fiber Optic Assemblies |
| Series | 88530 |
| Connector to Connector | SMI-to-SMI |
| Mode | Multimode |
| Overview | fiber optic product families |
| Product Name | Small Media Interface (SMI) |

Physical

| | |
|-----------------------|----------------|
| Cable Length | 0.14m (5.51") |
| Cable Size | 2.20mm (.087") |
| Fiber (Core/Cladding) | 980/1000µm |
| Single Ended | Yes |
| Wire/Cable Type | Fiber Optic |

Material Info

Reference - Drawing Numbers

| | |
|---------------|--------------|
| Sales Drawing | SD-88530-001 |
|---------------|--------------|

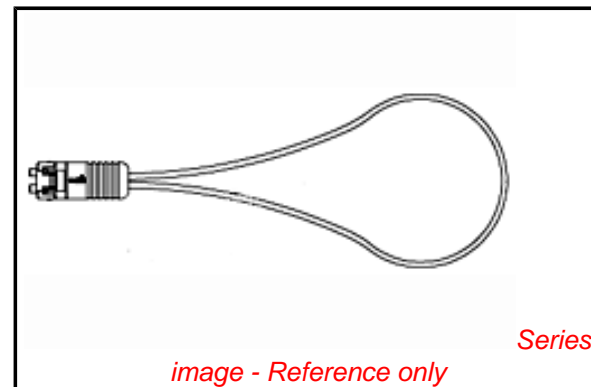

image - Reference only

EU RoHS

**ELV and RoHS
Compliant**
**REACH SVHC
Not Reviewed**
**Halogen-Free
Status**

China RoHS



**Need more information on product
environmental compliance?**

Email productcompliance@molex.com
 For a multiple part number RoHS Certificate of
 Compliance, [click here](#)

Please visit the [Contact Us](#) section for any
 non-product compliance questions.

Search Parts in this Series
[88530Series](#)

7 6 5 4 3 2 1

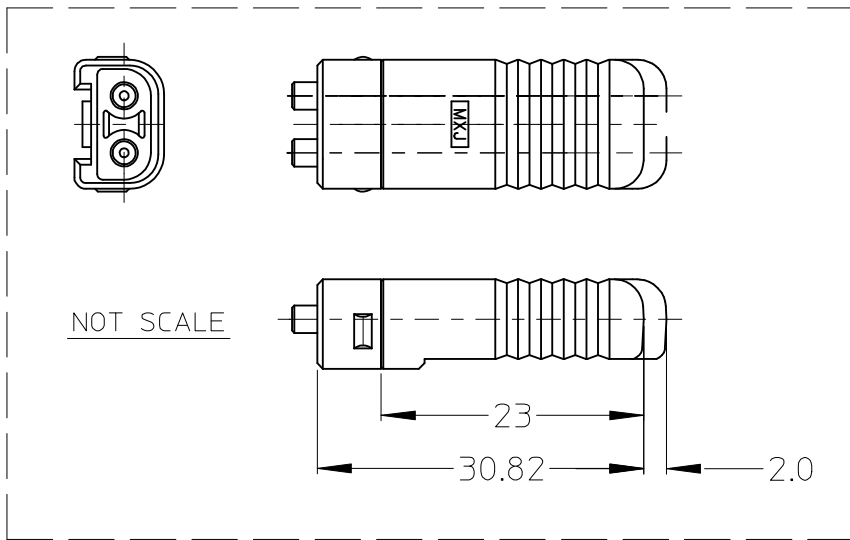
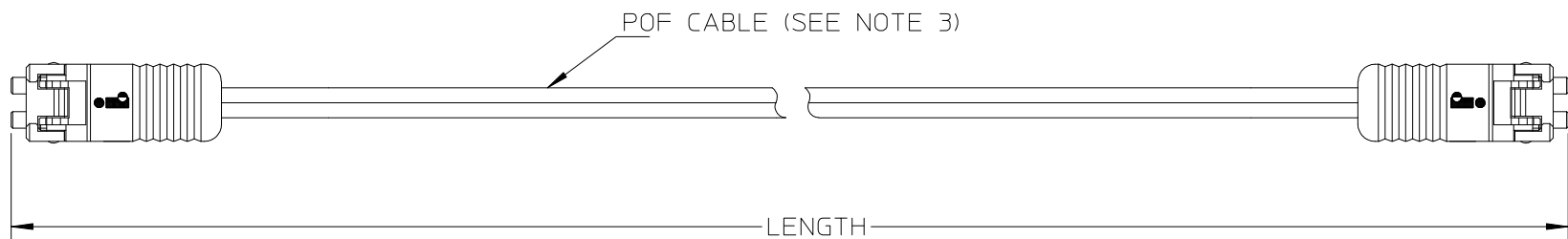

| | | | |
|---------------|----------------------------|----------------|---------------|
| 885319810 | SMI-SMI DUP POF 2.2MM 0.3M | 300(+50/-0) | <=3.0 |
| 885319809 | SMI-SMI DUP POF 2.2MM 15M | 15000(+200/-0) | <=6.0 |
| 885319808 | SMI-SMI DUP POF 2.2MM 0.2M | 200(+50/-0) | <=3.0 |
| 885319807 | SMI-SMI DUP POF 2.2MM 50M | 50000(+300/-0) | <=13.0 |
| 885319806 | SMI-SMI DUP POF 2.2MM 30M | 30000(+300/-0) | <=9.0 |
| 885319805 | SMI-SMI DUP POF 2.2MM 20M | 20000(+200/-0) | <=7.0 |
| 885319804 | SMI-SMI DUP POF 2.2MM 10M | 10000(+200/-0) | <=5.0 |
| 885319803 | SMI-SMI DUP POF 2.2MM 5M | 5000(+200/-0) | <=4.0 |
| 885319802 | SMI-SMI DUP POF 2.2MM 3M | 3000(+200/-0) | <=3.6 |
| 885319801 | SMI-SMI DUP POF 2.2MM 2M | 2000(+200/-0) | <=3.4 |
| 885319800 | SMI-SMI DUP POF 2.2MM 1M | 1000(+100/-0) | <=3.2 |
| MX P/N | DESCRIPTION | LENGTH | IL(dB) |

- NOTES:
- DUST CAPS ARE NOT SHOWN
 - IL MUST BE ACCORD TO RIGHT CHART PER CHANNEL @ 650nm. TEST DATA WILL BE PROVIDED WITH EACH PACKING
 - BLACK STEP INDEX Mitsubishi MHV400 POF CABLE, CABLE CORE SIZE IS 1mm
 - THE ASSEMBLY IS RoHS COMPLIANT

| | | | | | | | | | | |
|---|--|--------------------------------------|---|---------|-----------------------------------|---------------------|--------------------------------|------------------------|------------------------------|---------------------|
| ENTER DESCRIPTION EC NO: DG2009-0116 DRWN:XPCHEN CHKD: APPR:JOWANG | 2009/05/21 2009/05/21 2009/05/21 | QUALITY SYMBOLS ▽=0 ◻=0 | GENERAL TOLERANCES (UNLESS SPECIFIED) | | DIMENSION STYLE MM ONLY | SCALE --- | DESIGN UNITS METRIC | THIRD ANGLE PROJECTION | | |
| | | | 4 PLACES ±--- ±--- 3 PLACES ±--- ±--- 2 PLACES ±--- ±--- 1 PLACE ±--- ±--- | mm INCH | DRAWN BY XP | DATE 2006/06/29 | TITLE SMI-SMI DUP POF 2.2MM | | | |
| | | | ANGULAR ±---° | | CHECKED BY LISA | DATE 2006/06/29 | APPROVED BY JOHNNY | | | |
| | | | DRAFT WHERE APPLICABLE MUST REMAIN WITHIN DIMENSIONS | | MATERIAL NO. SEE TABLE | DATE 2006/06/29 | MOLEX INCORPORATED | | DOCUMENT NO. SD-88531-980 | SHEET NO. 1 OF 1 |

6 5 4 3 2 1