

1. Overview

1.1 Features

The M32C/8A Group is a single-chip control MCU, fabricated using high-performance silicon gate CMOS technology, embedding the M32C/80 Series CPU core. The M32C/8A Group is housed in 144-pin and 100-pin plastic molded LQFP packages.

With a 16-Mbyte address space, this MCU combines advanced instruction manipulation capabilities to process complex instructions by less bytes and execute instructions at higher speed.

The M32C/8A Group has a multiplier and DMAC adequate for office automation, communication devices and industrial equipment, and other high-speed processing applications.

The M32C/8A Group is ROMless device.
Use the M32C/8A Group in microprocessor mode after reset.

1.1.1 Applications

Audio, cameras, office/communication/portable equipment, etc.

1.1.2 Specifications

Tables 1.11.3 to 1.4 lists the specifications of the M32C/8A Group.

Table 1.1 Specifications (144-Pin Version) (1)

Item	Function	Specification
CPU	Central processing unit	M32C/80 core (multiplier: 16 bits × 16 bits → 32 bits, multiply-addition operation instructions: 16 × 16 + 48 → 48 bits) <ul style="list-style-type: none"> • Basic instructions: 108 • Minimum instruction execution time: 31.3 ns (f(CPU) = 32 MHZ / VCC1 = 4.2 to 5.5 V) 41.7 ns (f(CPU) = 24 MHZ / VCC1 = 3.0 to 5.5 V) • Operating mode: microprocessor mode
Memory	ROM, RAM	See Table 1.5 Product List .
Power Supply Voltage Detection		Vdet3 detection function, Vdet4 detection function, cold start/warm start determination function
External Bus Expansion	Bus / memory expansion function	<ul style="list-style-type: none"> • Address space: 16 Mbyte • External bus interface: 1 to 7 wait states can be inserted, 4 chip select outputs, 3 V and 5 V interfaces • Bus format: Switchable between separate and multiplexed bus formats, switchable data bus width (8-bit or 16-bit)
Clock	Clock generation circuits	<ul style="list-style-type: none"> • 4 circuits: Main clock, sub clock, on-chip oscillator, PLL frequency synthesizer • Oscillation stop detection: Main clock oscillation stop detection function • Frequency divider circuit: Dividing ratio selectable among 1, 2, 3, 4, 6, 8, 10, 12, 14, 16 • Low power consumption features: Wait mode, stop mode
Interrupts		<ul style="list-style-type: none"> • Interrupt vectors: 70 • External interrupt inputs: NMI × 1 INT × 3 (16-bit external bus width) INT × 6 (8-bit external bus width) Key input × 4 • Interrupt priority levels: 7
Watchdog Timer		15-bit × 1 (with prescaler)
DMA	DMAC	<ul style="list-style-type: none"> • 4 channels, cycle steal method • Trigger sources: 31 • Transfer modes: 2 (single transfer and repeat transfer)
	DMAC II	<ul style="list-style-type: none"> • Can be activated by all peripheral function interrupt sources • Transfer modes: 2 (single transfer and burst transfer) • Immediate transfer, calculation transfer, and chain transfer functions
Timer	Timer A	16-bit timer × 5 Timer mode, event counter mode, one-shot timer mode, pulse width modulation (PWM) mode) Event counter 2-phase pulse signal processing (2-phase encoder input) × 3
	Timer B	16-bit timer × 6 Timer mode, event counter mode, pulse period measurement mode, pulse width measurement mode
	Timer function for 3-phase motor control	3-phase inverter control × 1 (using timer A1, timer A2, timer A4, and timer B2) On-chip dead time timer

Table 1.2 Specifications (144-Pin Version) (2)

Item	Function	Specification
Serial Interface	UART0 to UART4	Clock synchronous / asynchronous x 5 I ² C bus (optional) ⁽²⁾ , special mode 2, GCI mode, SIM mode IEBus (optional) ⁽¹⁾⁽²⁾
A/D Converter		10-bit resolution x 18 channels, includes sample and hold function
D/A Converter		8-bit resolution x 2 channels
CRC Calculation Circuit		CRC-CCITT ($X^{16} + X^{12} + X^5 + 1$) compliant
X/Y Converter		16 bits x 16 bits
I/O Ports	Programmable I/O ports	<ul style="list-style-type: none"> • Input only: 1 • CMOS I/O: <ul style="list-style-type: none"> 81 (8-bit external bus width) 73 (16-bit external bus width) with selectable pull-up resistor • N channel open drain ports: 2
Operating Frequency / Supply Voltage		32 MHz: VCC1 = 4.2 to 5.5 V, VCC2 = 3.0 to VCC1 24 MHz: VCC1 = 3.0 to 5.5 V, VCC2 = 3.0 to VCC1
Current Consumption		28 mA (32 MHz / VCC1 = VCC2 = 5 V) 22 mA (24 MHz / VCC1 = VCC2 = 3.3 V) 45 μ A (approx. 1 MHz / VCC1 = VCC2 = 3.3 V, on-chip oscillator low-power consumption mode \rightarrow wait mode) 0.8 μ A (VCC1 = VCC2 = 3.3 V, stop mode)
Operating Ambient Temperature (°C)		-20 to 85°C, -40 to 85°C (optional) ⁽²⁾
Package		144-pin LQFP (PLQP0144KA-A)

NOTES:

1. IEBus is a registered trademark of NEC Electronics Corporation.
2. Please contact a Renesas sales office to use the optional feature.

Table 1.3 Specifications (100-Pin Version) (1)

Item	Function	Specification
CPU	Central processing unit	M32C/80 core (multiplier: 16 bits × 16 bits → 32 bits, multiply-addition operation instructions: 16 × 16 + 48 → 48 bits) <ul style="list-style-type: none"> • Basic instructions: 108 • Minimum instruction execution time: 31.3 ns (f(CPU) = 32 MHz / VCC1 = 4.2 to 5.5 V) 41.7 ns (f(CPU) = 24 MHz / VCC1 = 3.0 to 5.5 V) • Operating mode: microprocessor mode
Memory	ROM, RAM	See Table 1.5 Product List .
Power Supply Voltage Detection		Vdet3 detection function, Vdet4 detection function, cold start/warm start determination function
External Bus Expansion	Bus / memory expansion function	<ul style="list-style-type: none"> • Address space: 16 Mbyte • External bus interface: 1 to 7 wait states can be inserted, 4 chip select outputs, 3 V and 5 V interfaces • Bus format: Switchable between separate bus and multiplexed bus formats, switchable data bus width (8-bit or 16-bit)
Clock	Clock generation circuits	<ul style="list-style-type: none"> • 4 circuits: Main clock, sub clock, on-chip oscillator, PLL frequency synthesizer • Oscillation stop detection: Main clock oscillation stop detection function • Frequency divider circuit: Dividing ratio selectable among 1, 2, 3, 4, 6, 8, 10, 12, 14, 16 • Low power consumption features: Wait mode, stop mode
Interrupts		<ul style="list-style-type: none"> • Interrupt vectors: 70 • External interrupt inputs: NMI × 1 INT × 3 (16-bit external bus width) INT × 6 (8-bit external bus width) Key input × 4 • Interrupt priority levels: 7
Watchdog Timer		15-bit × 1 (with prescaler)
DMA	DMAC	<ul style="list-style-type: none"> • 4 channels, cycle steal method • Trigger sources: 31 • Transfer modes: 2 (single transfer and repeat transfer)
	DMACII	<ul style="list-style-type: none"> • Can be activated by all peripheral function interrupt sources • Transfer modes: 2 (single transfer and burst transfer) • Immediate transfer, calculation transfer, and chain transfer functions
Timer	Timer A	16-bit timer × 5 Timer mode, event counter mode, one-shot timer mode, pulse width modulation (PWM) mode Event counter 2-phase pulse signal processing (2-phase encoder input) × 3
	Timer B	16-bit timer × 6 Timer mode, event counter mode, pulse period measurement mode, pulse width measurement mode
	Timer function for 3-phase motor control	3-phase inverter control × 1 (using timer A1, timer A2, timer A4, and timer B2) On-chip dead time timer

Table 1.4 Specifications (100-Pin Version) (2)

Item	Function	Specification
Serial Interface	UART0 to UART4	Clock synchronous / asynchronous x 5 I ² C bus (optional) ⁽²⁾ , special mode 2, GCI mode, SIM mode IEBus (optional) ⁽¹⁾⁽²⁾
A/D Converter		10-bit resolution x 10 channels, includes sample and hold function
D/A Converter		8-bit resolution x 2 channels
CRC Calculation Circuit		CRC-CCITT ($X^{16} + X^{12} + X^5 + 1$) compliant
X/Y Converter		16 bits x 16 bits
I/O Ports	Programmable I/O ports	<ul style="list-style-type: none"> • Input only: 1 • CMOS I/O: <ul style="list-style-type: none"> 45 (8-bit external bus width) 37 (16-bit external bus width) with selectable pull-up resistor • N channel open drain ports: 2
Operating Frequency / Supply Voltage		32 MHz: VCC1 = 4.2 to 5.5 V, VCC2 = 3.0 to VCC1 24 MHz: VCC1 = 3.0 to 5.5 V, VCC2 = 3.0 to VCC1
Current Consumption		28 mA (32 MHz / VCC1 = VCC2 = 5 V) 22 mA (24 MHz / VCC1 = VCC2 = 3.3 V) 45 μ A (approx. 1 MHz / VCC1 = VCC2 = 3.3 V, on-chip oscillator low-power consumption mode \rightarrow wait mode) 0.8 μ A (VCC1 = VCC2 = 3.3 V, stop mode)
Operating Ambient Temperature (°C)		-20 to 85°C, -40 to 85°C (optional) ⁽²⁾
Package		100-pin LQFP (PLQP0100KB-A)

NOTES:

1. IEBus is a registered trademark of NEC Electronics Corporation.
2. Please contact a Renesas sales office for optional features.

1.2 Product List

Table 1.5 lists product information. Figure 1.1 shows product numbering system.

Table 1.5 Product List (M32C/8A) **Current as of July. 2007**

Type No.	Package	ROM Capacity	RAM Capacity	Remarks
M308A0SGP	PLQP0100KB-A (100P6Q-A)	-	12KB	ROMless
M308A3SGP (P)	PLQP0100KB-A (100P6Q-A)		24KB	ROMless
M308A5SGP (P)	PLQP0144KA-A (144P6Q-A)		24KB	ROMless

(P): Under planning

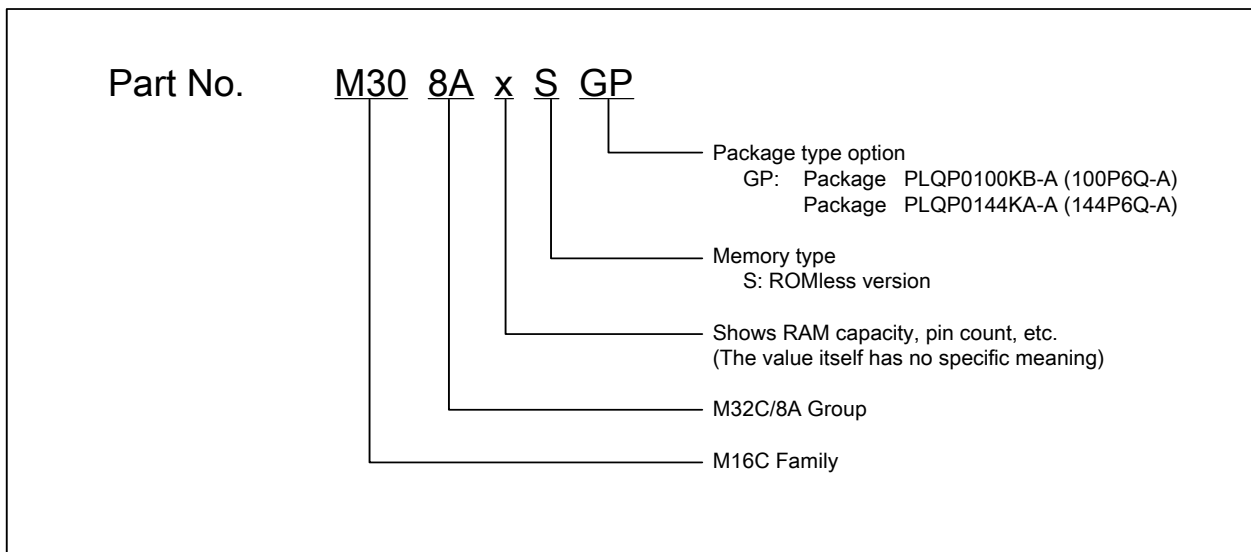

Figure 1.1 Product Numbering System

1.3 Block Diagram

Figure 1.2 shows a M32C/8A Group block diagram.

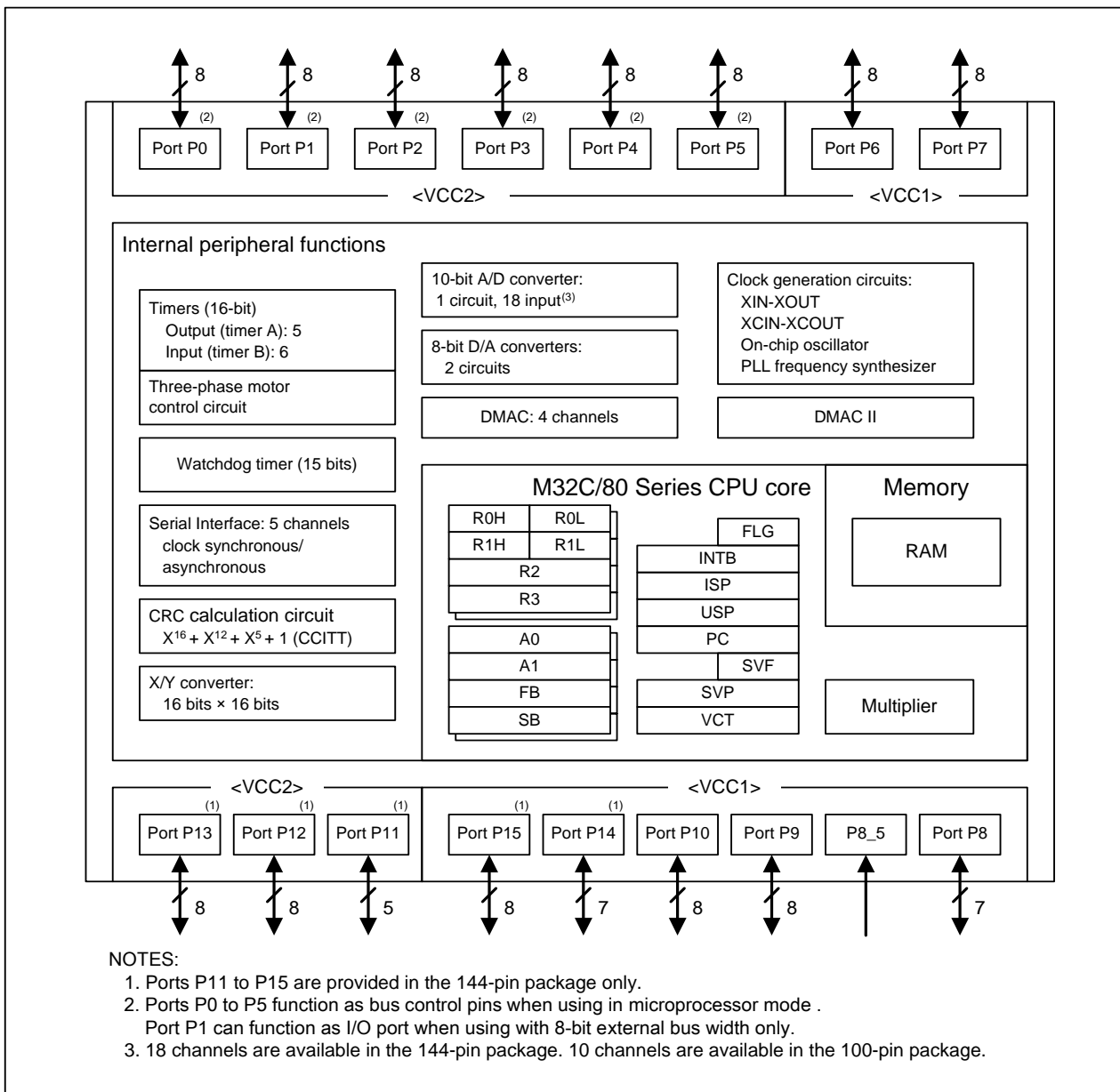

Figure 1.2 M32C/8A Group Block Diagram

1.4 Pin Assignments

Figures 1.3 and 1.4 show a pin assignment (top view).

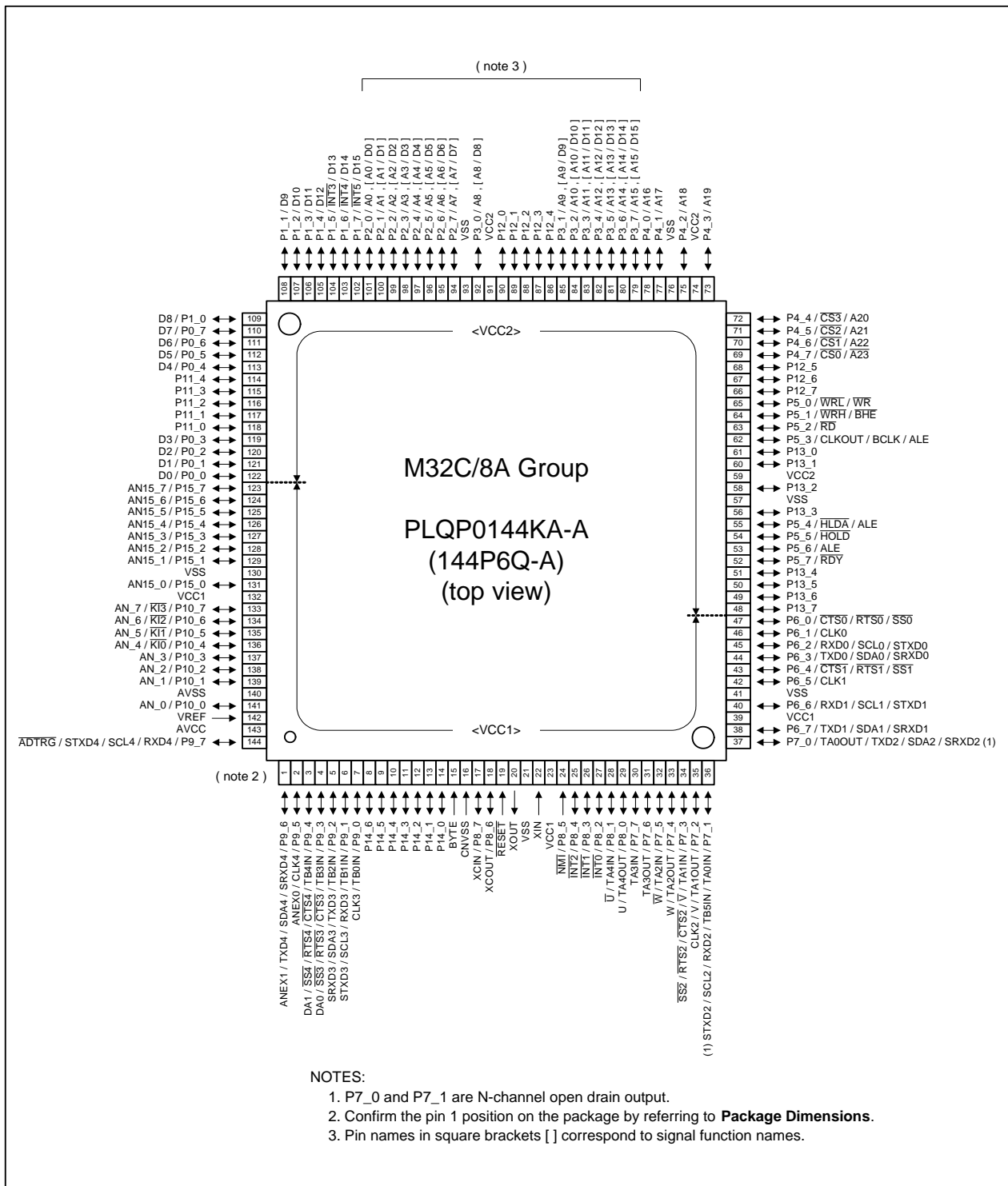

Figure 1.3 Pin Assignment for 144-pin Package

Table 1.6 144-Pin Version List of Pin Names (1)

Pin No.	Control Pin	Port	Interrupt Pin	Timer Pin	UART Pin	Analog Pin	Bus Control Pin
1		P9_6			TXD4/SDA4/SRXD4	ANEX1	
2		P9_5			CLK4	ANEX0	
3		P9_4		TB4IN	$\overline{\text{CTS4/RTS4/SS4}}$	DA1	
4		P9_3		TB3IN	$\overline{\text{CTS3/RTS3/SS3}}$	DA0	
5		P9_2		TB2IN	TXD3/SDA3/SRXD3		
6		P9_1		TB1IN	RXD3/SCL3/STXD3		
7		P9_0		TB0IN	CLK3		
8		P14_6					
9		P14_5					
10		P14_4					
11		P14_3					
12		P14_2					
13		P14_1					
14		P14_0					
15	BYTE						
16	CNVSS						
17	XCIN	P8_7					
18	XCOU	P8_6					
19	RESET						
20	XOUT						
21	VSS						
22	XIN						
23	VCC1						
24		P8_5	$\overline{\text{NMI}}$				
25		P8_4	$\overline{\text{INT2}}$				
26		P8_3	$\overline{\text{INT1}}$				
27		P8_2	$\overline{\text{INT0}}$				
28		P8_1		TA4IN $\overline{\text{U}}$			
29		P8_0		TA4OUT/U			
30		P7_7		TA3IN			
31		P7_6		TA3OUT			
32		P7_5		TA2IN $\overline{\text{W}}$			
33		P7_4		TA2OUT/W			
34		P7_3		TA1IN $\overline{\text{V}}$	$\overline{\text{CTS2/RTS2/SS2}}$		
35		P7_2		TA1OUT/V	CLK2		
36		P7_1		TA0IN/TB5IN	RXD2/SCL2/STXD2		
37		P7_0		TA0OUT	TXD2/SDA2/SRXD2		
38		P6_7			TXD1/SDA1/SRXD1		
39	VCC1						
40		P6_6			RXD1/SCL1/STXD1		
41	VSS						
42		P6_5			CLK1		
43		P6_4			$\overline{\text{CTS1/RTS1/SS1}}$		
44		P6_3			TXD0/SDA0/SRXD0		
45		P6_2			RXD0/SCL0/STXD0		
46		P6_1			CLK0		
47		P6_0			$\overline{\text{CTS0/RTS0/SS0}}$		
48		P13_7					
49		P13_6					
50		P13_5					

Table 1.7 144-Pin Version List of Pin Names (2)

Pin No.	Control Pin	Port	Interrupt Pin	Timer Pin	UART Pin	Analog Pin	Bus Control Pin
51		P13_4					
52		P5_7					$\overline{\text{RDY}}$
53		P5_6					ALE
54		P5_5					$\overline{\text{HOLD}}$
55		P5_4					$\overline{\text{HLDA/ALE}}$
56		P13_3					
57	VSS						
58		P13_2					
59	VCC2						
60		P13_1					
61		P13_0					
62	CLKOUT	P5_3					BCLK/ALE
63		P5_2					$\overline{\text{RD}}$
64		P5_1					$\overline{\text{WRH/BHE}}$
65		P5_0					$\overline{\text{WRL/WR}}$
66		P12_7					
67		P12_6					
68		P12_5					
69		P4_7					$\overline{\text{CS0/A23}}$
70		P4_6					$\overline{\text{CS1/A22}}$
71		P4_5					$\overline{\text{CS2/A21}}$
72		P4_4					$\overline{\text{CS3/A20}}$
73		P4_3					A19
74	VCC2						
75		P4_2					A18
76	VSS						
77		P4_1					A17
78		P4_0					A16
79		P3_7					A15,[A15/D15]
80		P3_6					A14,[A14/D14]
81		P3_5					A13,[A13/D13]
82		P3_4					A12,[A12/D12]
83		P3_3					A11,[A11/D11]
84		P3_2					A10,[A10/D10]
85		P3_1					A9,[A9/D9]
86		P12_4					
87		P12_3					
88		P12_2					
89		P12_1					
90		P12_0					
91	VCC2						
92		P3_0					A8,[A8/D8]
93	VSS						
94		P2_7					A7,[A7/D7]
95		P2_6					A6,[A6/D6]
96		P2_5					A5,[A5/D5]
97		P2_4					A4,[A4/D4]
98		P2_3					A3,[A3/D3]
99		P2_2					A2,[A2/D2]
100		P2_1					A1,[A1/D1]

Table 1.8 144-Pin Version List of Pin Names (3)

Pin No.	Control Pin	Port	Interrupt Pin	Timer Pin	UART Pin	Analog Pin	Bus Control Pin
101		P2_0					A0,[A0/D0]
102		P1_7	$\overline{\text{INT5}}$				D15
103		P1_6	$\overline{\text{INT4}}$				D14
104		P1_5	$\overline{\text{INT3}}$				D13
105		P1_4					D12
106		P1_3					D11
107		P1_2					D10
108		P1_1					D9
109		P1_0					D8
110		P0_7					D7
111		P0_6					D6
112		P0_5					D5
113		P0_4					D4
114		P11_4					
115		P11_3					
116		P11_2					
117		P11_1					
118		P11_0					
119		P0_3					D3
120		P0_2					D2
121		P0_1					D1
122		P0_0					D0
123		P15_7				AN15_7	
124		P15_6				AN15_6	
125		P15_5				AN15_5	
126		P15_4				AN15_4	
127		P15_3				AN15_3	
128		P15_2				AN15_2	
129		P15_1				AN15_1	
130	VSS						
131		P15_0				AN15_0	
132	VCC1						
133		P10_7	$\overline{\text{KI3}}$			AN_7	
134		P10_6	$\overline{\text{KI2}}$			AN_6	
135		P10_5	$\overline{\text{KI1}}$			AN_5	
136		P10_4	$\overline{\text{KI0}}$			AN_4	
137		P10_3				AN_3	
138		P10_2				AN_2	
139		P10_1				AN_1	
140	AVSS						
141		P10_0				AN_0	
142	VREF						
143	AVCC						
144		P9_7			RXD4/SCL4/STXD4	$\overline{\text{ADTRG}}$	

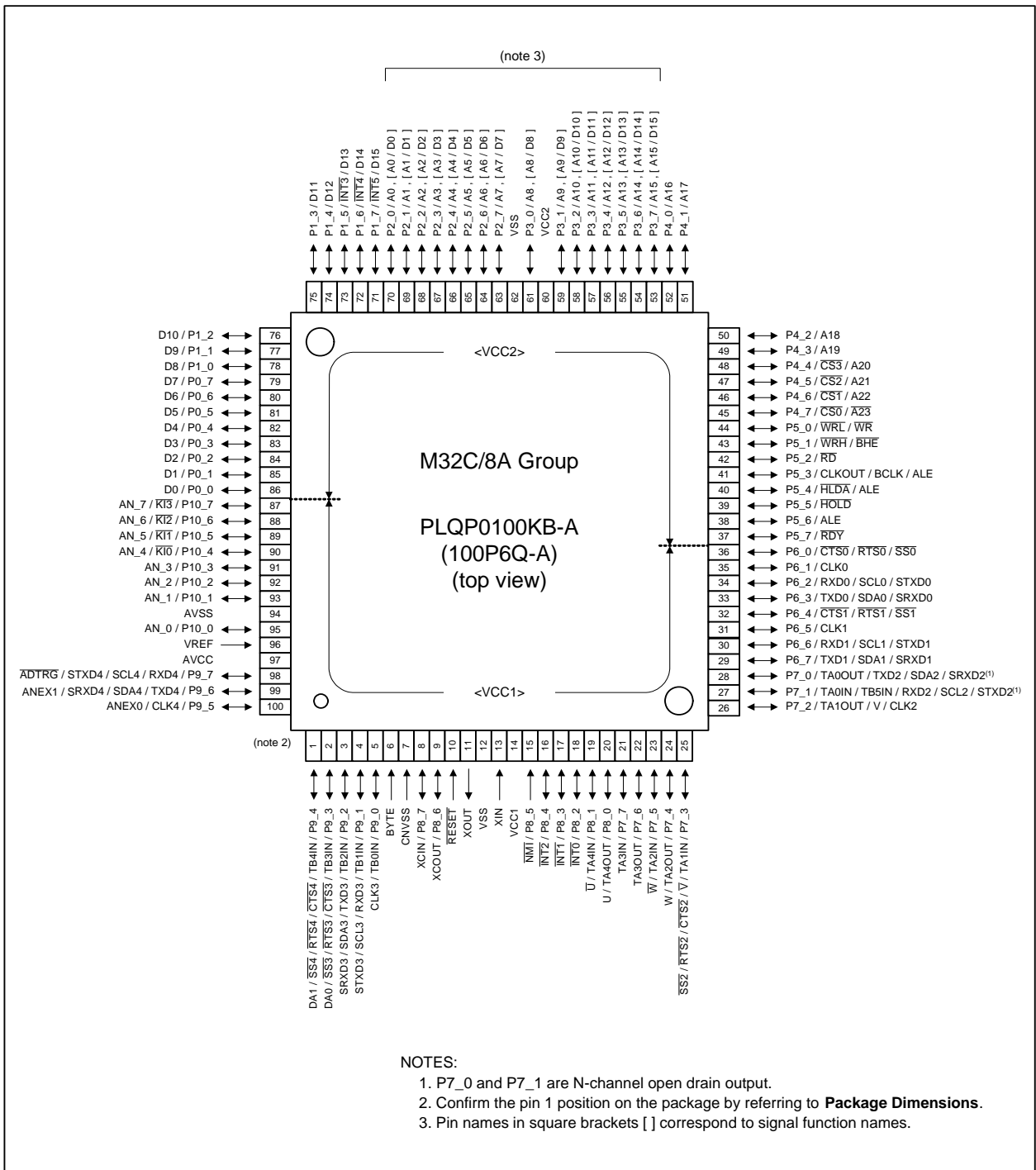

Figure 1.4 Pin Assignment for 100-pin Package

Table 1.9 100-Pin Version List of Pin Names (1)

Pin No.	Control Pin	Port	Interrupt Pin	Timer Pin	UART Pin	Analog Pin	Bus Control Pin
1		P9_4		TB4IN	$\overline{\text{CTS4/RTS4/SS4}}$	DA1	
2		P9_3		TB3IN	$\overline{\text{CTS3/RTS3/SS3}}$	DA0	
3		P9_2		TB2IN	TXD3/SDA3/SRXD3		
4		P9_1		TB1IN	RXD3/SCL3/STXD3		
5		P9_0		TB0IN	CLK3		
6	BYTE						
7	CNVSS						
8	XCIN	P8_7					
9	XCOUT	P8_6					
10	$\overline{\text{RESET}}$						
11	XOUT						
12	VSS						
13	XIN						
14	VCC1						
15		P8_5	$\overline{\text{NMI}}$				
16		P8_4	$\overline{\text{INT2}}$				
17		P8_3	$\overline{\text{INT1}}$				
18		P8_2	$\overline{\text{INT0}}$				
19		P8_1		TA4IN $\overline{\text{U}}$			
20		P8_0		TA4OUT/U			
21		P7_7		TA3IN			
22		P7_6		TA3OUT			
23		P7_5		TA2IN $\overline{\text{W}}$			
24		P7_4		TA2OUT/W			
25		P7_3		TA1IN $\overline{\text{V}}$	$\overline{\text{CTS2/RTS2/SS2}}$		
26		P7_2		TA1OUT/V	CLK2		
27		P7_1		TA0IN/TB5IN	RXD2/SCL2/STXD2		
28		P7_0		TA0OUT	TXD2/SDA2/SRXD2		
29		P6_7			TXD1/SDA1/SRXD1		
30		P6_6			RXD1/SCL1/STXD1		
31		P6_5			CLK1		
32		P6_4			$\overline{\text{CTS1/RTS1/SS1}}$		
33		P6_3			TXD0/SDA0/SRXD0		
34		P6_2			RXD0/SCL0/STXD0		
35		P6_1			CLK0		
36		P6_0			$\overline{\text{CTS0/RTS0/SS0}}$		
37		P5_7					$\overline{\text{RDY}}$
38		P5_6					ALE
39		P5_5					HOLD
40		P5_4					$\overline{\text{HLDA/ALE}}$
41	CLKOUT	P5_3					BCLK/ALE
42		P5_2					$\overline{\text{RD}}$
43		P5_1					$\overline{\text{WRH/BHE}}$
44		P5_0					$\overline{\text{WRL/WR}}$
45		P4_7					$\overline{\text{CS0/A23}}$
46		P4_6					$\overline{\text{CS1/A22}}$
47		P4_5					$\overline{\text{CS2/A21}}$
48		P4_4					$\overline{\text{CS3/A20}}$
49		P4_3					A19
50		P4_2					A18

Table 1.10 100-Pin Version List of Pin Names (2)

Pin No.	Control Pin	Port	Interrupt Pin	Timer Pin	UART Pin	Analog Pin	Bus Control Pin
51		P4_1					A17
52		P4_0					A16
53		P3_7					A15,[A15/D15]
54		P3_6					A14,[A14/D14]
55		P3_5					A13,[A13/D13]
56		P3_4					A12,[A12/D12]
57		P3_3					A11,[A11/D11]
58		P3_2					A10,[A10/D10]
59		P3_1					A9,[A9/D9]
60	VCC2						
61		P3_0					A8,[A8/D8]
62	VSS						
63		P2_7					A7,[A7/D7]
64		P2_6					A6,[A6/D6]
65		P2_5					A5,[A5/D5]
66		P2_4					A4,[A4/D4]
67		P2_3					A3,[A3/D3]
68		P2_2					A2,[A2/D2]
69		P2_1					A1,[A1/D1]
70		P2_0					A0,[A0/D0]
71		P1_7	$\overline{\text{INT5}}$				D15
72		P1_6	$\overline{\text{INT4}}$				D14
73		P1_5	$\overline{\text{INT3}}$				D13
74		P1_4					D12
75		P1_3					D11
76		P1_2					D10
77		P1_1					D9
78		P1_0					D8
79		P0_7					D7
80		P0_6					D6
81		P0_5					D5
82		P0_4					D4
83		P0_3					D3
84		P0_2					D2
85		P0_1					D1
86		P0_0					D0
87		P10_7	$\overline{\text{KI3}}$			AN_7	
88		P10_6	$\overline{\text{KI2}}$			AN_6	
89		P10_5	$\overline{\text{KI1}}$			AN_5	
90		P10_4	$\overline{\text{KI0}}$			AN_4	
91		P10_3				AN_3	
92		P10_2				AN_2	
93		P10_1				AN_1	
94	AVSS						
95		P10_0				AN_0	
96	VREF						
97	AVCC						
98		P9_7			RXD4/SCL4/STXD4	$\overline{\text{ADTRG}}$	
99		P9_6			TXD4/SDA4/SRXD4	ANEX1	
100		P9_5			CLK4	ANEX0	

1.5 Pin Functions

Table 1.11 Pin Functions (1) (100-Pin Package and 144-Pin Package)

Item	Pin Name	I/O Type	Supply Voltage	Description
Power supply	VCC1,VCC2 VSS	–	–	Apply 3.0 to 5.5 V to pins VCC1 and VCC2, and 0 V to the VSS pin. The input condition of $VCC1 \geq VCC2$ must be met.
Analog power supply input	AVCC AVSS	–	VCC1	Power supply input pins to the A/D converter and D/A converter. Connect the AVCC pin to VCC1, and the AVSS pin to VSS.
Reset input	\overline{RESET}	I	VCC1	The MCU is placed in a reset state when applying an “L” signal to the \overline{RESET} pin.
CNVSS	CNVSS	I	VCC1	This pin switches processor mode. Apply an “H” signal to the CNVSS pin to start up in microprocessor mode.
External data bus width select input	BYTE	I	VCC1	This pin switches data bus width in external memory space 3. A data bus is 16 bits wide when the BYTE pin is held “L” and 8 bits wide when it is held “H”.
Bus control Pins	D0 to D7	I/O	VCC2	Data (D0 to D7) input/output pins while accessing an external memory space with separate bus.
	D8 to D15	I/O	VCC2	Data (D8 to D15) inputs/output pins while accessing an external memory space with 16-bit separate bus.
	A0 to A22	O	VCC2	Address bits (A0 to A22) output pins.
	$\overline{A23}$	O	VCC2	Inverted address bit (A23) output pin.
	A0/D0 to A7/D7	I/O	VCC2	Data (D0 to D7) input/output and 8 low-order address bits (A0 to A7) output are performed by time-sharing these pins while accessing an external memory space with multiplexed bus.
	A8/D8 to A15/D15	I/O	VCC2	Data (D8 to D15) input/output and 8 middle-order address bits (A8 to A15) output are performed by time-sharing these pins while accessing an external memory space with 16-bit multiplexed bus.
	$\overline{CS0}$ to $\overline{CS3}$	O	VCC2	Chip-select signal output pins used to specify external devices.
	$\overline{WRL}/\overline{WR}$ $\overline{WRH}/\overline{BHE}$ \overline{RD}	O	VCC2	\overline{WRL} , \overline{WRH} , (\overline{WR} , \overline{BHE}) and \overline{RD} signal output pins. \overline{WRL} and \overline{WRH} can be switched with \overline{WR} and \overline{BHE} by program. <ul style="list-style-type: none"> • \overline{WRL}, \overline{WRH} and \overline{RD} are selected: If external data bus is 16 bits wide, data is written to an even address in external memory space while an “L” is output from the \overline{WRL} pin. Data is written to an odd address while an “L” is output from the \overline{WRH} pin. Data is read while an “L” is output from the \overline{RD} pin. • \overline{WR}, \overline{BHE} and \overline{RD} are selected: Data is written while an “L” is output from the \overline{WR} pin. Data is read while an “L” is output from the \overline{RD} pin. Data in odd address is accessed while an “L” is output from the \overline{BHE} pin. Select \overline{WR}, \overline{BHE} and \overline{RD} when an external data bus is 8 bits wide.
	ALE	O	VCC2	ALE signal is used for the external devices to latch address signals when the multiplexed bus is selected.
	\overline{HOLD}	I	VCC2	The MCU is placed in a hold state while an “L” signal is applied to the \overline{HOLD} pin.
\overline{HLDA}	O	VCC2	The \overline{HLDA} pin outputs an “L” while the MCU is placed in a hold state	
\overline{RDY}	I	VCC2	Bus is placed in a wait state while an “L” signal is applied to the \overline{RDY} pin.	

Table 1.12 Pin Functions (2) (100-Pin Package and 144-Pin Package)

Item	Pin Name	I/O Type	Supply Voltage	Description
Main clock input	XIN	I	VCC1	Input/output pins for the main clock oscillation circuit. Connect a ceramic resonator or crystal oscillator between XIN and XOUT. To apply an external clock, apply it to XIN and leave XOUT open
Main clock output	XOUT	O	VCC1	
Sub clock input	XCIN	I	VCC1	Input/output pins for the sub clock oscillation circuit. Connect a crystal oscillator between XCIN and XCOU. To apply an external clock, apply it to XCIN and leave XCOU open.
Sub clock output	XCOU	O	VCC1	
BCLK output	BCLK	O	VCC2	Bus clock output pin
Clock output	CLKOUT	O	VCC2	The CLKOUT pin outputs the clock having the same frequency as f _C , f ₈ , or f ₃₂
$\overline{\text{INT}}$ interrupt input	$\overline{\text{INT}}_0$ to $\overline{\text{INT}}_2$	I	VCC1	$\overline{\text{INT}}$ interrupt input pins
	$\overline{\text{INT}}_3$ to $\overline{\text{INT}}_5$	I	VCC2	
$\overline{\text{NMI}}$ interrupt input	$\overline{\text{NMI}}$	I	VCC1	$\overline{\text{NMI}}$ interrupt input pin. Connect the $\overline{\text{NMI}}$ pin to VCC1 via a resistor when the NMI interrupt is not used.
Timer A	TA0OUT to TA4OUT	I/O	VCC1	Timer A0 to A4 input/output pins (TA0OUT is N-channel open drain output)
	TA0IN to TA4IN	I	VCC1	Timer A0 to A4 input pins
Timer B	TB0IN to TB5IN	I	VCC1	Timer B0 to B5 input pins
Three-phase motor control timer output	U, $\overline{\text{U}}$, V, $\overline{\text{V}}$, W, $\overline{\text{W}}$	O	VCC1	Three-phase motor control timer output pins
Serial interface	$\overline{\text{CTS}}_0$ to $\overline{\text{CTS}}_4$	I	VCC1	Input pins to control data transmission
	$\overline{\text{RTS}}_0$ to $\overline{\text{RTS}}_4$	O	VCC1	Output pins to control data reception
	CLK0 to CLK4	I/O	VCC1	Serial clock input/output pins
	RXD0 to RXD4	I	VCC1	Serial data input pins
	TXD0 to TXD4	O	VCC1	Serial data output pins (TXD2 is N-channel open drain output)
I ² C mode	SDA0 to SDA4	I/O	VCC1	Serial data input/output pins (SDA2 is N-channel open drain output)
	SCL0 to SCL4	I/O	VCC1	Serial clock input/output pins (SCL2 is N-channel open drain output)
Serial interface special function	STXD0 to STXD4	O	VCC1	Serial data output pins when slave mode is selected (STXD2 is N-channel open drain output)
	SRXD0 to SRXD4	I	VCC1	Serial data input pins when slave mode is selected
	$\overline{\text{SS}}_0$ to $\overline{\text{SS}}_4$	I	VCC1	Control input pins used in the serial interface special mode.

Table 1.13 Pin Functions (3) (100-Pin Package and 144-Pin Package)

Item	Pin Name	I/O Type	Supply Voltage	Description
Reference voltage input	VREF	I	–	The VREF pin supplies the reference voltage to the A/D converter and D/A converter.
A/D converter	AN_0 to AN_7	I	VCC1	Analog input pins for the A/D converter.
	ADTRG	I	VCC1	External trigger input pin for the A/D converter.
	ANEX0	I/O	VCC1	Extended analog input pin for the A/D converter or output pin in external op-amp connection mode.
	ANEX1	I	VCC1	Extended analog input pin for the A/D converter.
D/A converter	DA0, DA1	O	VCC1	Output pins for the D/A converter.
I/O port	P0_0 to P0_7, P1_0 to P1_7, P2_0 to P2_7, P3_0 to P3_7, P4_0 to P4_7, P5_0 to P5_7	I/O ⁽¹⁾	VCC2	8-bit CMOS I/O ports. The Port Pi Direction Register determines if each pin is used as an input port or an output port. The Pull-up Control Register determines if the input ports, divided into groups of four, are pulled up or not.
	P6_0 to P6_7, P7_0 to P7_7, P9_0 to P9_7, P10_0 to P10_7	I/O	VCC1	These 8-bit I/O ports are functionally equivalent to P0. (P7_0 and P7_1 are N-channel open drain output.)
	P8_0 to P8_4 P8_6, P8_7			These I/O ports are functionally equivalent to P0.
Input port	P8_5	I	VCC1	Shares the pin with $\overline{\text{NMI}}$. Input port to read $\overline{\text{NMI}}$ pin level.
Key input interrupt input	$\overline{\text{KI0}}$ to $\overline{\text{KI3}}$	I	VCC1	Key input interrupt input pins

NOTE:

1. P0 to P5 function as bus control pins and cannot be used as I/O ports. P1_0 to P1_7 can be used as I/O ports when using with 8-bit external bus width only.

Table 1.14 Pin Functions (4) (144-Pin Package Only)

Item	Pin Name	I/O Type	Supply Voltage	Description
A/D converter	AN15_0 to AN15_7	I	VCC1	Analog input pins for the A/D converter
I/O ports	P11_0 to P11_4, P12_0 to P12_7, P13_0 to P13_7	I/O	VCC2	These I/O ports are functionally equivalent to P0.
	P14_0 to P14_6, P15_0 to P15_7	I/O	VCC1	

2. Central Processing Unit (CPU)

Figure 2.1 shows the CPU registers.

The register bank is comprised of eight registers (R0, R1, R2, R3, A0, A1, SB, and FB) out of 28 CPU registers. There are two sets of register banks.

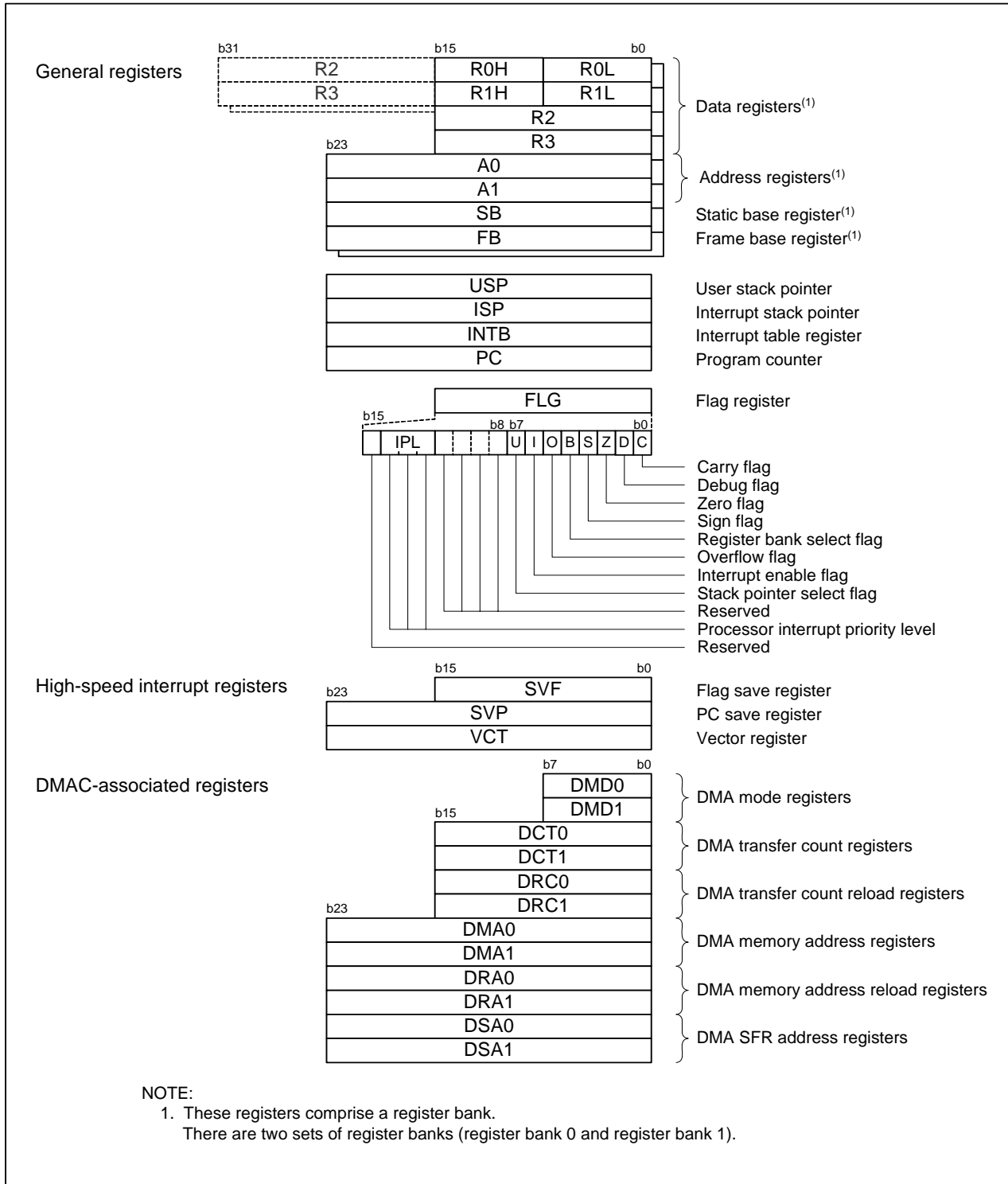

Figure 2.1 CPU Register

2.1 General Registers

2.1.1 Data Registers (R0, R1, R2, and R3)

R0, R1, R2, and R3 are 16-bit registers for transfer, arithmetic and logic operations. R0 and R1 can be split into high-order (R0H/R1H) and low-order bits (R0L/R1L) to be used separately as 8-bit data registers. R0 can be combined with R2 and used as a 32-bit data register (R2R0). The same applies to R3R1.

2.1.2 Address Registers (A0 and A1)

A0 and A1 are 24-bit registers used for A0-/A1-indirect addressing, A0-/A1-relative addressing, transfer, arithmetic and logic operations.

2.1.3 Static Base Register (SB)

SB is a 24-bit register used for SB-relative addressing.

2.1.4 Frame Base Register (FB)

FB is a 24-bit register used for FB-relative addressing.

2.1.5 User Stack Pointer (USP) and Interrupt Stack Pointer (ISP)

The stack pointers (SP), USP and ISP, are 24 bits wide each. The U flag is used to switch between USP and ISP. Refer to **2.1.8 Flag Register (FLG)** for details on the U flag. Set USP and ISP to even addresses to execute an interrupt sequence efficiently.

2.1.6 Interrupt Table Register (INTB)

INTB is a 24-bit register indicating the starting address of a relocatable interrupt vector table.

2.1.7 Program Counter (PC)

PC is 24 bits wide and indicates the address of the next instruction to be executed.

2.1.8 Flag Register (FLG)

FLG is a 16-bit register indicating the CPU state.

2.1.8.1 Carry Flag (C)

The C flag indicates whether or not carry or borrow has been generated after executing an instruction.

2.1.8.2 Debug Flag (D)

The D flag is for debugging only. Set it to 0.

2.1.8.3 Zero Flag (Z)

The Z flag becomes 1 when an arithmetic operation results in 0; otherwise becomes 0.

2.1.8.4 Sign Flag (S)

The S flag becomes 1 when an arithmetic operation results in a negative value; otherwise becomes 0.

2.1.8.5 Register Bank Select Flag (B)

Register bank 0 is selected when the B flag is set to 0. Register bank 1 is selected when this flag is set to 1.

2.1.8.6 Overflow Flag (O)

The O flag becomes 1 when an arithmetic operation results in an overflow; otherwise becomes 0.

2.1.8.7 Interrupt Enable Flag (I)

The I flag enables maskable interrupts.

Interrupts are disabled when the I flag is set to 0 and enabled when it is set to 1. The I flag becomes 0 when an interrupt request is acknowledged.

2.1.8.8 Stack Pointer Select Flag (U)

ISP is selected when the U flag is set to 0. USP is selected when the U flag is set to 1.

The U flag becomes 0 when a hardware interrupt request is acknowledged or the INT instruction specifying software interrupt numbers 0 to 31 is executed.

2.1.8.9 Processor Interrupt Priority Level (IPL)

IPL is 3 bits wide and assigns processor interrupt priority levels from level 0 to level 7.

If a requested interrupt has higher priority than IPL, the interrupt is enabled.

2.1.8.10 Reserved Space

Only write 0 to bits assigned to the reserved space. When read, the bits return undefined values.

2.2 High-Speed Interrupt Registers

Registers associated with the high-speed interrupt are follows:

- Save flag register (SVF)
- Save PC register (SVP)
- Vector register (VCT)

2.3 DMAC-Associated Registers

Registers associated with the DMAC are as follows:

- DMA mode register (DMD0, DMD1)
- DMA transfer count register (DCT0, DCT1)
- DMA transfer count reload register (DRC0, DRC1)
- DMA memory address register (DMA0, DMA1)
- DMA memory address reload register (DRA0, DRA1)
- DMA SFR address register (DSA0, DSA1)

3. Memory

Figure 3.1 is a memory map of the M32C/8A Group.

The M32C/8A Group has 16-Mbyte address space from addresses 000000h to FFFFFFFh.

The fixed interrupt vectors are allocated addresses FFFFDCh to FFFFFFFh. They store the starting address of each interrupt routine.

The internal RAM is allocated higher addresses, beginning with address 000400h. For example, a 12-Kbyte internal RAM area is allocated addresses 000400h to 0033FFh. The internal RAM is used not only for storing data but for the stacks when subroutines are called or when interrupt requests are acknowledged.

SFRs are allocated address 000000h to 0003FFh. The peripheral function control registers such as for I/O ports, A/D converters, serial interfaces, timers are allocated here. All blank spaces within SFRs are reserved and cannot be accessed by users.

The special page vectors are allocated addresses FFFE00h to FFFFDBh. They are used for the JMPS instruction and JSRS instruction. Refer to the Renesas publication **M32C/80 Series Software Manual** for details.

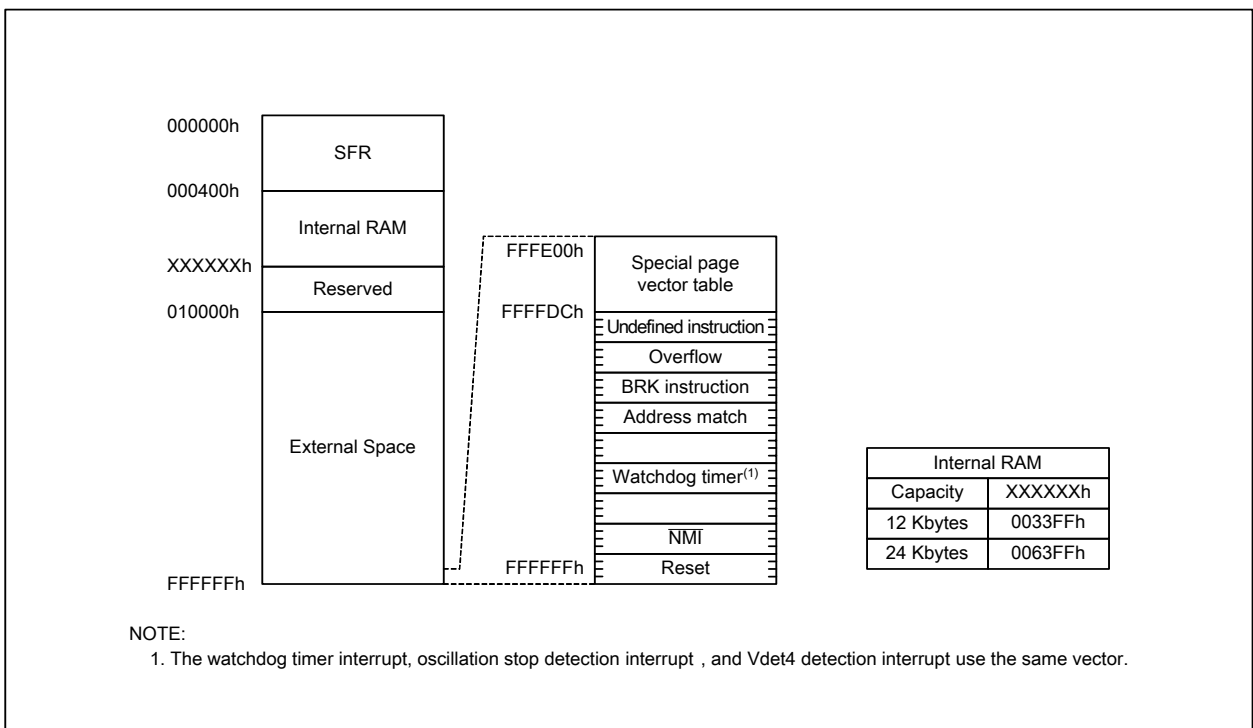

Figure 3.1 Memory Map

4. Special Function Registers (SFRs)

Special Function Registers (SFRs) are the control registers of peripheral functions. Tables 4.1 to 4.11 list SFR address maps.

Table 4.1 SFR Address Map (1)

Address	Register	Symbol	After Reset
0000h			
0001h			
0002h			
0003h			
0004h	Processor Mode Register 0 ⁽¹⁾	PM0	0000 0011b(CNVSS="H")
0005h	Processor Mode Register 1	PM1	00h
0006h	System Clock Control Register 0	CM0	0000 1000b
0007h	System Clock Control Register 1	CM1	0010 0000b
0008h			
0009h	Address Match Interrupt Enable Register	AIER	00h
000Ah	Protect Register	PRCR	XXXX 0000b
000Bh	External Data Bus Width Control Register	DS	XXXX 1000b(BYTE="L") XXXX 0000b(BYTE="H")
000Ch	Main Clock Division Register	MCD	XXXX 1000b
000Dh	Oscillation Stop Detection Register	CM2	00h
000Eh	Watchdog Timer Start Register	WDTS	XXh
000Fh	Watchdog Timer Control Register	WDC	00XX XXXXb
0010h			
0011h	Address Match Interrupt Register 0	RMAD0	000000h
0012h			
0013h	Processor Mode Register 2	PM2	00h
0014h			
0015h	Address Match Interrupt Register 1	RMAD1	000000h
0016h			
0017h	Voltage Detection Register 2	VCR2	00h
0018h			
0019h	Address Match Interrupt Register 2	RMAD2	000000h
001Ah			
001Bh	Voltage Detection Register 1	VCR1	0000 1000b
001Ch			
001Dh	Address Match Interrupt Register 3	RMAD3	000000h
001Eh			
001Fh			
0020h			
0021h			
0022h			
0023h			
0024h			
0025h			
0026h	PLL Control Register 0	PLC0	0001 X010b
0027h	PLL Control Register 1	PLC1	000X 0000b
0028h			
0029h	Address Match Interrupt Register 4	RMAD4	000000h
002Ah			
002Bh			
002Ch			
002Dh	Address Match Interrupt Register 5	RMAD5	000000h
002Eh			
002Fh	Vdet4 Detection Interrupt Register	D4INT	XX00 0000b

X: Undefined

Blank spaces are all reserved. No access is allowed.

NOTE:

1. Bits PM01 and PM00 in the PM0 register maintain values set before reset, even after software reset or watchdog timer reset has been performed.

Table 4.2 SFR Address Map (2)

Address	Register	Symbol	After Reset
0030h			
0031h			
0032h			
0033h			
0034h			
0035h			
0036h			
0037h			
0038h			
0039h	Address Match Interrupt Register 6	RMAD6	000000h
003Ah			
003Bh			
003Ch			
003Dh	Address Match Interrupt Register 7	RMAD7	000000h
003Eh			
003Fh			
0040h			
0041h			
0042h			
0043h			
0044h			
0045h			
0046h			
0047h			
0048h	External Space Wait Control Register 0	EWCR0	X0X0 0011b
0049h	External Space Wait Control Register 1	EWCR1	X0X0 0011b
004Ah	External Space Wait Control Register 2	EWCR2	X0X0 0011b
004Bh	External Space Wait Control Register 3	EWCR3	X0X0 0011b
004Ch	Page Mode Wait Control Register 0	PWCR0	0001 0001b
004Dh	Page Mode Wait Control Register 1	PWCR1	0001 0001b
004Eh			
004Fh			
0050h			
0051h			
0052h			
0053h			
0054h			
0055h			
0056h			
0057h			
0058h			
0059h			
005Ah			
005Bh			
005Ch			
005Dh			
005Eh			
005Fh			

X: Undefined

Blank spaces are all reserved. No access is allowed.

Table 4.3 SFR Address Map (3)

Address	Register	Symbol	After Reset
0060h			
0061h			
0062h			
0063h			
0064h			
0065h			
0066h			
0067h			
0068h	DMA0 Interrupt Control Register	DM0IC	XXXX X000b
0069h	Timer B5 Interrupt Control Register	TB5IC	XXXX X000b
006Ah	DMA2 Interrupt Control Register	DM2IC	XXXX X000b
006Bh	UART2 Receive/ACK Interrupt Control Register	S2RIC	XXXX X000b
006Ch	Timer A0 Interrupt Control Register	TA0IC	XXXX X000b
006Dh	UART3 Receive/ACK Interrupt Control Register	S3RIC	XXXX X000b
006Eh	Timer A2 Interrupt Control Register	TA2IC	XXXX X000b
006Fh	UART4 Receive/ACK Interrupt Control Register	S4RIC	XXXX X000b
0070h	Timer A4 Interrupt Control Register	TA4IC	XXXX X000b
0071h	UART0/UART3 Bus Conflict Detection Interrupt Control Register	BCN0IC/BCN3IC	XXXX X000b
0072h	UART0 Receive/ACK Interrupt Control Register	S0RIC	XXXX X000b
0073h	A/D0 Conversion Interrupt Control Register	AD0IC	XXXX X000b
0074h	UART1 Receive/ACK Interrupt Control Register	S1RIC	XXXX X000b
0075h			
0076h	Timer B1 Interrupt Control Register	TB1IC	XXXX X000b
0077h			
0078h	Timer B3 Interrupt Control Register	TB3IC	XXXX X000b
0079h			
007Ah	$\overline{\text{INT5}}$ Interrupt Control Register	INT5IC	XX00 X000b
007Bh			
007Ch	$\overline{\text{INT3}}$ Interrupt Control Register	INT3IC	XX00 X000b
007Dh			
007Eh	$\overline{\text{INT1}}$ Interrupt Control Register	INT1IC	XX00 X000b
007Fh			
0080h			
0081h			
0082h			
0083h			
0084h			
0085h			
0086h			
0087h			
0088h	DMA1 Interrupt Control Register	DM1IC	XXXX X000b
0089h	UART2 Transmit/NACK Interrupt Control Register	S2TIC	XXXX X000b
008Ah	DMA3 Interrupt Control Register	DM3IC	XXXX X000b
008Bh	UART3 Transmit/NACK Interrupt Control Register	S3TIC	XXXX X000b
008Ch	Timer A1 Interrupt Control Register	TA1IC	XXXX X000b
008Dh	UART4 Transmit/NACK Interrupt Control Register	S4TIC	XXXX X000b
008Eh	Timer A3 Interrupt Control Register	TA3IC	XXXX X000b
008Fh	UART2 Bus Conflict Detection Interrupt Control Register	BCN2IC	XXXX X000b

X: Undefined

Blank spaces are all reserved. No access is allowed.

Table 4.4 SFR Address Map (4)

Address	Register	Symbol	After Reset
0090h	UART0 Transmit/NACK Interrupt Control Register	S0TIC	XXXX X000b
0091h	UART1/UART4 Bus Conflict Detection Interrupt Control Register	BCN1IC/BCN4IC	XXXX X000b
0092h	UART1 Transmit/NACK Interrupt Control Register	S1TIC	XXXX X000b
0093h	Key Input Interrupt Control Register	KUPIC	XXXX X000b
0094h	Timer B0 Interrupt Control Register	TB0IC	XXXX X000b
0095h			
0096h	Timer B2 Interrupt Control Register	TB2IC	XXXX X000b
0097h			
0098h	Timer B4 Interrupt Control Register	TB4IC	XXXX X000b
0099h			
009Ah	$\overline{\text{INT4}}$ Interrupt Control Register	INT4IC	XX00 X000b
009Bh			
009Ch	$\overline{\text{INT2}}$ Interrupt Control Register	INT2IC	XX00 X000b
009Dh			
009Eh	$\overline{\text{INT0}}$ Interrupt Control Register	INT0IC	XX00 X000b
009Fh	Exit Priority Register	RLVL	XXXX 0000b
00A0h			
00A1h			
00A2h			
00A3h			
00A4h			
00A5h			
00A6h			
00A7h			
00A8h			
00A9h			
00AAh			
00ABh			
00ACh			
00ADh			
00AEh			
00AFh			
00B0h			
00B1h			
00B2h			
00B3h			
00B4h			
00B5h			
00B6h			
00B7h			
00B8h			
00B9h			
00BAh			
00BBh			
00BCh			
00BDh			
00BEh			
00BFh to 02BFh			

X: Undefined

Blank spaces are all reserved. No access is allowed.

Table 4.5 SFR Address Map (5)

Address	Register	Symbol	After Reset
02C0h	X0 Register, Y0 Register	X0R, Y0R	XXXXh
02C1h			
02C2h	X1 Register, Y1 Register	X1R, Y1R	XXXXh
02C3h			
02C4h	X2 Register, Y2 Register	X2R, Y2R	XXXXh
02C5h			
02C6h	X3 Register, Y3 Register	X3R, Y3R	XXXXh
02C7h			
02C8h	X4 Register, Y4 Register	X4R, Y4R	XXXXh
02C9h			
02CAh	X5 Register, Y5 Register	X5R, Y5R	XXXXh
02CBh			
02CCh	X6 Register, Y6 Register	X6R, Y6R	XXXXh
02CDh			
02CEh	X7 Register, Y7 Register	X7R, Y7R	XXXXh
02CFh			
02D0h	X8 Register, Y8 Register	X8R, Y8R	XXXXh
02D1h			
02D2h	X9 Register, Y9 Register	X9R, Y9R	XXXXh
02D3h			
02D4h	X10 Register, Y10 Register	X10R, Y10R	XXXXh
02D5h			
02D6h	X11 Register, Y11 Register	X11R, Y11R	XXXXh
02D7h			
02D8h	X12 Register, Y12 Register	X12R, Y12R	XXXXh
02D9h			
02DAh	X13 Register, Y13 Register	X13R, Y13R	XXXXh
02DBh			
02DCh	X14 Register, Y14 Register	X14R, Y14R	XXXXh
02DDh			
02DEh	X15 Register, Y15 Register	X15R, Y15R	XXXXh
02DFh			
02E0h	X/Y Control Register	XYC	XXXX XX00b
02E1h			
02E2h			
02E3h			
02E4h	UART1 Special Mode Register 4	U1SMR4	00h
02E5h	UART1 Special Mode Register 3	U1SMR3	00h
02E6h	UART1 Special Mode Register 2	U1SMR2	00h
02E7h	UART1 Special Mode Register	U1SMR	00h
02E8h	UART1 Transmit/Receive Mode Register	U1MR	00h
02E9h	UART1 Baud Rate Register	U1BRG	XXh
02EAh	UART1 Transmit Buffer Register	U1TB	XXXXh
02EBh			
02ECh	UART1 Transmit/Receive Control Register 0	U1C0	0000 1000b
02EDh	UART1 Transmit/Receive Control Register 1	U1C1	0000 0010b
02EEh	UART1 Receive Buffer Register	U1RB	XXXXh
02EFh			

X: Undefined

Blank spaces are all reserved. No access is allowed.

Table 4.6 SFR Address Map (6)

Address	Register	Symbol	After Reset
02F0h			
02F1h			
02F2h			
02F3h			
02F4h	UART4 Special Mode Register 4	U4SMR4	00h
02F5h	UART4 Special Mode Register 3	U4SMR3	00h
02F6h	UART4 Special Mode Register 2	U4SMR2	00h
02F7h	UART4 Special Mode Register	U4SMR	00h
02F8h	UART4 Transmit/Receive Mode Register	U4MR	00h
02F9h	UART4 Baud Rate Register	U4BRG	XXh
02FAh	UART4 Transmit Buffer Register	U4TB	XXXXh
02FBh			
02FCh	UART4 Transmit/Receive Control Register 0	U4C0	0000 1000b
02FDh	UART4 Transmit/Receive Control Register 1	U4C1	0000 0010b
02FEh	UART4 Receive Buffer Register	U4RB	XXXXh
02FFh			
0300h	Timer B3, B4, B5 Count Start Register	TBSR	000X XXXXb
0301h			
0302h	Timer A11 Register	TA11	XXXXh
0303h			
0304h	Timer A21 Register	TA21	XXXXh
0305h			
0306h	Timer A41 Register	TA41	XXXXh
0307h			
0308h	Three-Phase PWM Control Register 0	INVC0	00h
0309h	Three-Phase PWM Control Register 1	INVC1	00h
030Ah	Three-Phase Output Buffer Register 0	IDB0	XX11 1111b
030Bh	Three-Phase Output Buffer Register 1	IDB1	XX11 1111b
030Ch	Dead Time Timer	DTT	XXh
030Dh	Timer B2 Interrupt Generation Frequency Set Counter	ICTB2	XXh
030Eh			
030Fh			
0310h	Timer B3 Register	TB3	XXXXh
0311h			
0312h	Timer B4 Register	TB4	XXXXh
0313h			
0314h	Timer B5 Register	TB5	XXXXh
0315h			
0316h			
0317h			
0318h			
0319h			
031Ah			
031Bh	Timer B3 Mode Register	TB3MR	00XX 0000b
031Ch	Timer B4 Mode Register	TB4MR	00XX 0000b
031Dh	Timer B5 Mode Register	TB5MR	00XX 0000b
031Eh			
031Fh	External Interrupt Source Select Register	IFSR	00h

X: Undefined

Blank spaces are all reserved. No access is allowed.

Table 4.7 SFR Address Map (7)

Address	Register	Symbol	After Reset
0320h			
0321h			
0322h			
0323h			
0324h	UART3 Special Mode Register 4	U3SMR4	00h
0325h	UART3 Special Mode Register 3	U3SMR3	00h
0326h	UART3 Special Mode Register 2	U3SMR2	00h
0327h	UART3 Special Mode Register	U3SMR	00h
0328h	UART3 Transmit/Receive Mode Register	U3MR	00h
0329h	UART3 Baud Rate Register	U3BRG	XXh
032Ah	UART3 Transmit Buffer Register	U3TB	XXXXh
032Bh			
032Ch	UART3 Transmit/Receive Control Register 0	U3C0	0000 1000b
032Dh	UART3 Transmit/Receive Control Register 1	U3C1	0000 0010b
032Eh	UART3 Receive Buffer Register	U3RB	XXXXh
032Fh			
0330h			
0331h			
0332h			
0333h			
0334h	UART2 Special Mode Register 4	U2SMR4	00h
0335h	UART2 Special Mode Register 3	U2SMR3	00h
0336h	UART2 Special Mode Register 2	U2SMR2	00h
0337h	UART2 Special Mode Register	U2SMR	00h
0338h	UART2 Transmit/Receive Mode Register	U2MR	00h
0339h	UART2 Baud Rate Register	U2BRG	XXh
033Ah	UART2 Transmit Buffer Register	U2TB	XXXXh
033Bh			
033Ch	UART2 Transmit/Receive Control Register 0	U2C0	0000 1000b
033Dh	UART2 Transmit/Receive Control Register 1	U2C1	0000 0010b
033Eh	UART2 Receive Buffer Register	U2RB	XXXXh
033Fh			
0340h	Count Start Register	TABSR	00h
0341h	Clock Prescaler Reset Register	CPSRF	0XXX XXXXb
0342h	One-Shot Start Register	ONSF	00h
0343h	Trigger Select Register	TRGSR	00h
0344h	Up/Down Select Register	UDF	00h
0345h			
0346h	Timer A0 Register	TA0	XXXXh
0347h			
0348h	Timer A1 Register	TA1	XXXXh
0349h			
034Ah	Timer A2 Register	TA2	XXXXh
034Bh			
034Ch	Timer A3 Register	TA3	XXXXh
034Dh			
034Eh	Timer A4 Register	TA4	XXXXh
034Fh			

X: Undefined

Blank spaces are all reserved. No access is allowed.

Table 4.8 SFR Address Map (8)

Address	Register	Symbol	After Reset
0350h	Timer B0 Register	TB0	XXXXh
0351h			
0352h	Timer B1 Register	TB1	XXXXh
0353h			
0354h	Timer B2 Register	TB2	XXXXh
0355h			
0356h	Timer A0 Mode Register	TA0MR	00h
0357h	Timer A1 Mode Register	TA1MR	00h
0358h	Timer A2 Mode Register	TA2MR	00h
0359h	Timer A3 Mode Register	TA3MR	00h
035Ah	Timer A4 Mode Register	TA4MR	00h
035Bh	Timer B0 Mode Register	TB0MR	00XX 0000b
035Ch	Timer B1 Mode Register	TB1MR	00XX 0000b
035Dh	Timer B2 Mode Register	TB2MR	00XX 0000b
035Eh	Timer B2 Special Mode Register	TB2SC	XXXX XXX0b
035Fh	Count Source Prescaler Register ⁽¹⁾	TCSPR	0XXX 0000b
0360h			
0361h			
0362h			
0363h			
0364h	UART0 Special Mode Register 4	U0SMR4	00h
0365h	UART0 Special Mode Register 3	U0SMR3	00h
0366h	UART0 Special Mode Register 2	U0SMR2	00h
0367h	UART0 Special Mode Register	U0SMR	00h
0368h	UART0 Transmit/Receive Mode Register	U0MR	00h
0369h	UART0 Baud Rate Register	U0BRG	XXh
036Ah	UART0 Transmit Buffer Register	U0TB	XXXXh
036Bh			
036Ch	UART0 Transmit/Receive Control Register 0	U0C0	0000 1000b
036Dh	UART0 Transmit/Receive Control Register 1	U0C1	0000 0010b
036Eh	UART0 Receive Buffer Register	U0RB	XXXXh
036Fh			
0370h			
0371h			
0372h			
0373h			
0374h			
0375h			
0376h			
0377h			
0378h	DMA0 Request Source Select Register	DM0SL	0X00 0000b
0379h	DMA1 Request Source Select Register	DM1SL	0X00 0000b
037Ah	DMA2 Request Source Select Register	DM2SL	0X00 0000b
037Bh	DMA3 Request Source Select Register	DM3SL	0X00 0000b
037Ch	CRC Data Register	CRCD	XXXXh
037Dh			
037Eh	CRC Input Register	CRCIN	XXh
037Fh			

X: Undefined

Blank spaces are all reserved. No access is allowed.

NOTE:

1. The TCSPR register maintains values set before reset, even after software reset or watchdog timer reset has been performed.

Table 4.9 SFR Address Map (9)

Address	Register	Symbol	After Reset
0380h	A/D0 Register 0	AD00	00XXh
0381h			
0382h	A/D0 Register 1	AD01	00XXh
0383h			
0384h	A/D0 Register 2	AD02	00XXh
0385h			
0386h	A/D0 Register 3	AD03	00XXh
0387h			
0388h	A/D0 Register 4	AD04	00XXh
0389h			
038Ah	A/D0 Register 5	AD05	00XXh
038Bh			
038Ch	A/D0 Register 6	AD06	00XXh
038Dh			
038Eh	A/D0 Register 7	AD07	00XXh
038Fh			
0390h			
0391h			
0392h	A/D0 Control Register 4	AD0CON4	XXXX 00XXb
0393h			
0394h	A/D0 Control Register 2	AD0CON2	XX0X X000b
0395h	A/D0 Control Register 3	AD0CON3	XXXX X000b
0396h	A/D0 Control Register 0	AD0CON0	00h
0397h	A/D0 Control Register 1	AD0CON1	00h
0398h	D/A Register 0	DA0	XXh
0399h			
039Ah	D/A Register 1	DA1	XXh
039Bh			
039Ch	D/A Control Register	DACON	XXXX XX00b
039Dh			
039Eh			
039Fh			

X: Undefined

Blank spaces are all reserved. No access is allowed.

Table 4.10 SFR Address Map (10)

Address	Register	Address	Register
03A0h			
03A1h			
03A2h			
03A3h			
03A4h			
03A5h			
03A6h			
03A7h			
03A8h			
03A9h			
03AAh			
03ABh			
03ACh			
03ADh			
03AEh			
03AFh	Function Select Register C	PSC	00X0 0000b
03B0h	Function Select Register A0	PS0	00h
03B1h	Function Select Register A1	PS1	00h
03B2h	Function Select Register B0	PSL0	00h
03B3h	Function Select Register B1	PSL1	00h
03B4h	Function Select Register A2	PS2	00X0 0000b
03B5h	Function Select Register A3	PS3	00h
03B6h	Function Select Register B2	PSL2	00X0 0000b
03B7h	Function Select Register B3	PSL3	00h
03B8h			
03B9h			
03BAh			
03BBh			
03BCh			
03BDh			
03BEh			
03BFh			
03C0h	Port P6 Register	P6	XXh
03C1h	Port P7 Register	P7	XXh
03C2h	Port P6 Direction Register	PD6	00h
03C3h	Port P7 Direction Register	PD7	00h
03C4h	Port P8 Register	P8	XXh
03C5h	Port P9 Register	P9	XXh
03C6h	Port P8 Direction Register	PD8	00X0 0000b
03C7h	Port P9 Direction Register	PD9	00h
03C8h	Port P10 Register	P10	XXh
03C9h	Port P11 Register ⁽¹⁾	P11	XXh
03CAh	Port P10 Direction Register	PD10	00h
03CBh	Port P11 Direction Register ⁽¹⁾⁽²⁾	PD11	XXX0 0000b
03CCh	Port P12 Register ⁽¹⁾	P12	XXh
03CDh	Port P13 Register ⁽¹⁾	P13	XXh
03CEh	Port P12 Direction Register ⁽¹⁾⁽²⁾	PD12	00h
03CFh	Port P13 Direction Register ⁽¹⁾⁽²⁾	PD13	00h

X: Undefined

Blank spaces are all reserved. No access is allowed.

NOTES:

1. These registers cannot be used in the 100-pin package.
2. Set to FFh in the 100-pin package.

Table 4.11 SFR Address Map (11)

Address	Register	Address	Register
03D0h	Port P14 Register ⁽¹⁾	P14	XXh
03D1h	Port P15 Register ⁽¹⁾	P15	XXh
03D2h	Port P14 Direction Register ⁽¹⁾⁽²⁾	PD14	X000 0000b
03D3h	Port P15 Direction Register ⁽¹⁾⁽²⁾	PD15	00h
03D4h			
03D5h			
03D6h			
03D7h			
03D8h			
03D9h			
03DAh	Pull-Up Control Register 2	PUR2	00h
03DBh	Pull-Up Control Register 3	PUR3	00h
03DCh	Pull-Up Control Register 4 ⁽¹⁾⁽³⁾	PUR4	XXXX 0000b
03DDh			
03DEh			
03DFh			
03E0h	Port P0 Register	P0	XXh
03E1h	Port P1 Register	P1	XXh
03E2h	Port P0 Direction Register	PD0	00h
03E3h	Port P1 Direction Register	PD1	00h
03E4h	Port P2 Register	P2	XXh
03E5h	Port P3 Register	P3	XXh
03E6h	Port P2 Direction Register	PD2	00h
03E7h	Port P3 Direction Register	PD3	00h
03E8h	Port P4 Register	P4	XXh
03E9h	Port P5 Register	P5	XXh
03EAh	Port P4 Direction Register	PD4	00h
03EBh	Port P5 Direction Register	PD5	00h
03ECh			
03EDh			
03EEh			
03EFh			
03F0h	Pull-Up Control Register 0	PUR0	00h
03F1h	Pull-Up Control Register 1	PUR1	XXXX 0000b
03F2h			
03F3h			
03F4h			
03F5h			
03F6h			
03F7h			
03F8h			
03F9h			
03FAh			
03FBh			
03FCh			
03FDh			
03FEh			
03FFh	Port Control Register	PCR	XXXX XXX0b

X: Undefined

Blank spaces are all reserved. No access is allowed.

NOTES:

1. These registers cannot be used in the 100-pin package.
2. Set to FFh in the 100-pin package.
3. Set to 00h in the 100-pin package.

5. Electrical Characteristics

Table 5.1 Absolute Maximum Ratings

Symbol	Parameter		Condition	Value	Unit
VCC1, VCC2	Supply voltage		VCC1 = AVCC	-0.3 to 6.0	V
VCC2	Supply voltage		–	-0.3 to VCC1 + 0.1	V
AVCC	Analog supply voltage		VCC1 = AVCC	-0.3 to 6.0	V
VI	Input voltage	RESET, CNVSS, BYTE, P6_0 to P6_7, P7_2 to P7_7, P8_0 to P8_7, P9_0 to P9_7, P10_0 to P10_7, P14_0 to P14_6, P15_0 to P15_7 ⁽¹⁾ , VREF, XIN		-0.3 to VCC1 + 0.3	V
		P0_0 to P0_7, P1_0 to P1_7, P2_0 to P2_7, P3_0 to P3_7, P4_0 to P4_7, P5_0 to P5_7, P11_0 to P11_4, P12_0 to P12_7, P13_0 to P13_7 ⁽¹⁾		-0.3 to VCC2 + 0.3	
		P7_0, P7_1		-0.3 to 6.0	
VO	Output voltage	P6_0 to P6_7, P7_2 to P7_7, P8_0 to P8_4, P8_6, P8_7, P9_0 to P9_7, P10_0 to P10_7, P14_0 to P14_6, P15_0 to P15_7 ⁽¹⁾ , XOUT		-0.3 to VCC1 + 0.3	V
		P0_0 to P0_7, P1_0 to P1_7, P2_0 to P2_7, P3_0 to P3_7, P4_0 to P4_7, P5_0 to P5_7, P11_0 to P11_4, P12_0 to P12_7, P13_0 to P13_7 ⁽¹⁾		-0.3 to VCC2 + 0.3	
		P7_0, P7_1		-0.3 to 6.0	
Pd	Power dissipation		-40°C ≤ Topr ≤ 85°C	500	mW
Topr	Operating ambient temperature			-20 to 85/ -40 to 85 ⁽²⁾	°C
Tstg	Storage temperature			-65 to 150	°C

NOTES:

- P11 to P15 are provided in the 144-pin package only.
- Contact a Renesas sales office if temperature range of -40 to 85°C is required.

Table 5.2 Recommended Operating Conditions (1)
(VCC1 = VCC2 = 3.0 to 5.5 V, Topr = -20 to 85°C unless otherwise specified)

Symbol	Parameter		Standard			Unit
			Min.	Typ.	Max.	
VCC1, VCC2	Supply voltage (VCC1 ≥ VCC2)		3.0	5.0	5.5	V
AVCC	Analog supply voltage			VCC1		V
VSS	Supply voltage			0		V
AVSS	Analog supply voltage			0		V
VIH	Input high "H" voltage	P2_0 to P2_7, P3_0 to P3_7, P4_0 to P4_7, P5_0 to P5_7, P11_0 to P11_4, P12_0 to P12_7, P13_0 to P13_7 ⁽²⁾	0.8VCC2		VCC2	V
		P6_0 to P6_7, P7_2 to P7_7, P8_0 to P8_7 ⁽¹⁾ , P9_0 to P9_7, P10_0 to P10_7, P14_0 to P14_6, P15_0 to P15_7 ⁽²⁾ , XIN, RESET, CNVSS, BYTE	0.8VCC1		VCC1	
		P7_0, P7_1	0.8VCC1		6.0	
		P0_0 to P0_7, P1_0 to P1_7 (in microprocessor mode)	0.5VCC2		VCC2	
VIL	Input low "L" voltage	P2_0 to P2_7, P3_0 to P3_7, P4_0 to P4_7, P5_0 to P5_7, P11_0 to P11_4, P12_0 to P12_7, P13_0 to P13_7 ⁽²⁾	0		0.2VCC2	V
		P6_0 to P6_7, P7_0 to P7_7, P8_0 to P8_7 ⁽¹⁾ , P9_0 to P9_7, P10_0 to P10_7, P14_0 to P14_6, P15_0 to P15_7 ⁽²⁾ , XIN, RESET, CNVSS, BYTE	0		0.2VCC1	
		P0_0 to P0_7, P1_0 to P1_7 (in microprocessor mode)	0		0.16VCC2	

NOTES:

1. VIH and VIL reference for P8_7 apply when P8_7 is used as a programmable input port. It does not apply when P8_7 is used as XCIN.
2. P11 to P15 are provided in the 144-pin package only.

Table 5.3 Recommended Operating Conditions (2)
(VCC1 = VCC2 = 3.0 to 5.5 V, Topr = -20 to 85°C unless otherwise specified)

Symbol	Parameter	Standard			Unit
		Min.	Typ.	Max.	
IOH(peak)	Peak output high "H" current ⁽²⁾			-10.0	mA
IOH(avg)	Average output "H" current ⁽¹⁾			-5.0	mA
IOL(peak)	Peak output "L" current ⁽²⁾			10.0	mA
IOL(avg)	Average output "L" current ⁽¹⁾			5.0	mA

NOTES:

- Average output current is the average value within 100 ms.
- A total IOL(peak) of P0, P1, P2, P8_6, P8_7, P9, P10, P11, P14, and P15 must be 80 mA or less.
A total IOL(peak) of P3, P4, P5, P6, P7, P8_0 to P8_4, P12, and P13 must be 80 mA or less.
A total IOH(peak) of P0, P1, P2, and P11 must be -40 mA or less.
A total IOH(peak) of P8_6 to P8_7, P9, P10, P14, and P15 must be -40 mA or less.
A total IOH(peak) of P3, P4, P5, P12, and P13 must be -40 mA or less.
A total IOH(peak) of P6, P7, and P8_0 to P8_4 must be -40 mA or less.
- P11 to P15 are provided in the 144-pin package only.

Table 5.4 Recommended Operating Conditions (3)
(VCC1 = VCC2 = 3.0 to 5.5 V, Topr = -20 to 85°C unless otherwise specified)

Symbol	Parameter		Standard			Unit
			Min.	Typ.	Max.	
f(CPU)	CPU clock frequency (same frequency as f(BCLK))	VCC1 = 4.2 to 5.5V	0		32	MHz
		VCC1 = 3.0 to 5.5V	0		24	MHz
f(XIN)	Main clock input frequency	VCC1 = 4.2 to 5.5V	0		32	MHz
		VCC1 = 3.0 to 5.5V	0		24	MHz
f(XCIN)	Sub clock frequency			32.768	50	kHz
f(Ring)	On-chip oscillator frequency		0.5	1	2	MHz
f(VCO)	VCO clock frequency (PLL frequency synthesizer)		20		80	MHz
f(PLL)	PLL clock frequency	VCC1 = 4.2 to 5.5V	10		32	MHz
		VCC1 = 3.0 to 5.5V	10		24	MHz
tsu(PLL)	Wait time to stabilize PLL frequency synthesizer	VCC1 = 5.0V			5	ms
		VCC1 = 3.3V			10	ms

$$VCC1 = VCC2 = 5V$$

Table 5.5 Electrical Characteristics (1)
(VCC1 = VCC2 = 4.2 to 5.5 V, VSS = 0 V, Topr = -20 to 85°C, f(CPU) = 32 MHz unless otherwise specified)

Symbol	Parameter		Condition	Standard			Unit	
				Min.	Typ.	Max.		
VOH	Output high "H" voltage	P0_0 to P0_7, P1_0 to P1_7, P2_0 to P2_7, P3_0 to P3_7, P4_0 to P4_7, P5_0 to P5_7, P11_0 to P11_4, P12_0 to P12_7, P13_0 to P13_7 ⁽¹⁾	IOH = -5 mA	VCC2 - 2.0		VCC2	V	
		P6_0 to P6_7, P7_2 to P7_7, P8_0 to P8_4, P8_6, P8_7, P9_0 to P9_7, P10_0 to P10_7, P14_0 to P14_6, P15_0 to P15_7 ⁽¹⁾	IOH = -5 mA	VCC1 - 2.0		VCC1		
		P0_0 to P0_7, P1_0 to P1_7, P2_0 to P2_7, P3_0 to P3_7, P4_0 to P4_7, P5_0 to P5_7, P11_0 to P11_4, P12_0 to P12_7, P13_0 to P13_7 ⁽¹⁾	IOH = -200 μ A	VCC2 - 0.3		VCC2	V	
		P6_0 to P6_7, P7_2 to P7_7, P8_0 to P8_4, P8_6, P8_7, P9_0 to P9_7, P10_0 to P10_7, P14_0 to P14_6, P15_0 to P15_7 ⁽¹⁾	IOH = -200 μ A	VCC1 - 0.3		VCC1		
		XOUT	IOH = -1 mA	3.0		VCC1	V	
		XCOU	High drive capability	No load applied		2.5		V
	Low drive capability	No load applied		1.6		V		
VOL	Output low "L" voltage	P0_0 to P0_7, P1_0 to P1_7, P2_0 to P2_7, P3_0 to P3_7, P4_0 to P4_7, P5_0 to P5_7, P6_0 to P6_7, P7_0 to P7_7, P8_0 to P8_4, P8_6, P8_7, P9_0 to P9_7, P10_0 to P10_7, P11_0 to P11_4, P12_0 to P12_7, P13_0 to P13_7, P14_0 to P14_6, P15_0 to P15_7 ⁽¹⁾	IOL = 5 mA			2.0	V	
		P0_0 to P0_7, P1_0 to P1_7, P2_0 to P2_7, P3_0 to P3_7, P4_0 to P4_7, P5_0 to P5_7, P6_0 to P6_7, P7_0 to P7_7, P8_0 to P8_4, P8_6, P8_7, P9_0 to P9_7, P10_0 to P10_7, P11_0 to P11_4, P12_0 to P12_7, P13_0 to P13_7, P14_0 to P14_6, P15_0 to P15_7 ⁽¹⁾	IOL = 200 μ A			0.45		V
		XOUT	IOL = 1 mA			2.0	V	
		XCOU	High drive capability	No load applied		0		V
			Low drive capability	No load applied		0		V
		VT+ - VT-	Hysteresis	HOLD, RDY, TA0IN to TA4IN, TB0IN to TB5IN, INT0 to INT5, ADTRG, CTS0 to CTS4, CLK0 to CLK4, TA0OUT to TA4OUT, NMI, K10 to K13, RXD0 to RXD4, SCL0 to SCL4, SDA0 to SDA4		0.2		1.0
RESET				0.2		1.8	V	

NOTE:

- P11 to P15 are provided in the 144-pin package only.

$$VCC1 = VCC2 = 5V$$

Table 5.6 Electrical Characteristics (2)
(VCC1 = VCC2 = 4.2 to 5.5 V, VSS = 0 V, Topr = -20 to 85°C, f(CPU) = 32 MHz unless otherwise specified)

Symbol	Parameter		Condition	Standard			Unit
				Min.	Typ.	Max.	
IIH	Input high "H" current	P0_0 to P0_7, P1_0 to P1_7, P2_0 to P2_7, P3_0 to P3_7, P4_0 to P4_7, P5_0 to P5_7, P6_0 to P6_7, P7_0 to P7_7, P8_0 to P8_7, P9_0 to P9_7, P10_0 to P10_7, P11_0 to P11_4, P12_0 to P12_7, P13_0 to P13_7, P14_0 to P14_6, P15_0 to P15_7 ⁽¹⁾ , XIN, RESET, CNVSS, BYTE	VI = 5 V			5.0	μA
IIL	Input low "L" current	P0_0 to P0_7, P1_0 to P1_7, P2_0 to P2_7, P3_0 to P3_7, P4_0 to P4_7, P5_0 to P5_7, P6_0 to P6_7, P7_0 to P7_7, P8_0 to P8_7, P9_0 to P9_7, P10_0 to P10_7, P11_0 to P11_4, P12_0 to P12_7, P13_0 to P13_7, P14_0 to P14_6, P15_0 to P15_7 ⁽¹⁾ , XIN, RESET, CNVSS, BYTE	VI = 0V			-5.0	μA
RPULLUP	Pull-up resistance	P0_0 to P0_7, P1_0 to P1_7, P2_0 to P2_7, P3_0 to P3_7, P4_0 to P4_7, P5_0 to P5_7, P6_0 to P6_7, P7_2 to P7_7, P8_0 to P8_4, P8_6, P8_7, P9_0 to P9_7, P10_0 to P10_7, P11_0 to P11_4, P12_0 to P12_7, P13_0 to P13_7, P14_0 to P14_6, P15_0 to P15_7 ⁽¹⁾	VI = 0V	20	40	167	kΩ
RfXIN	Feedback resistance	XIN			1.5		MΩ
RfXCIN	Feedback resistance	XCIN			10		MΩ
VRAM	RAM data retention voltage	In stop mode		2.0			V

NOTE:

1. P11 to P15 are provided in the 144-pin package only.

Table 5.7 Electrical Characteristics (3) (VCC1 = VCC2 = 5.5 V, VSS = 0 V, Topr = 25°C)

Symbol	Parameter	Condition		Standard			Unit
				Min.	Typ.	Max.	
ICC	Power supply current	ROMless version	f(CPU) = 32 MHz		28	45	mA
			f(CPU) = 16 MHz		16		mA
			f(CPU) = 8 MHz		10		mA
			f(CPU) = f(Ring) In on-chip oscillator low-power consumption mode		1		mA
			f(CPU) = 32 kHz In low-power consumption mode		25		μA
			f(CPU) = f(Ring) After entering wait mode from on-chip oscillator low-power consumption mode		50		μA
			Stop mode (while clock is stopped)		0.8	5	μA
			Stop mode (while clock is stopped) Topr = 85°C			50	μA

$$VCC1 = VCC2 = 5V$$

Table 5.8 A/D Conversion Characteristics
(VCC1 = VCC2 = AVCC = VREF = 4.2 to 5.5 V, VSS = AVSS = 0 V, Topr = -20 to 85°C, f(CPU) = 32MHz unless otherwise specified)

Symbol	Parameter	Measurement Condition	Standard			Unit
			Min.	Typ.	Max.	
–	Resolution	VREF = VCC1			10	Bits
INL	Integral nonlinearity error	VREF = VCC1 = VCC2 = 5 V	AN_0 to AN_7, AN15_0 to AN15_7, ANEX0, ANEX1		±3	LSB
			External op-amp connection mode		±7	LSB
DNL	Differential nonlinearity error				±1	LSB
–	Offset error				±3	LSB
–	Gain error				±3	LSB
RLADDER	Resistor ladder	VREF = VCC1	8		40	kΩ
tCONV	10-bit conversion time ⁽¹⁾⁽²⁾		2.06			μs
tCONV	8-bit conversion time ⁽¹⁾⁽²⁾		1.75			μs
tSAMP	Sampling time ⁽¹⁾		0.188			μs
VREF	Reference voltage		2		VCC1	V
VIA	Analog input voltage		0		VREF	V

NOTES:

1. The value is obtained when φAD frequency is at 16 MHz. Keep φAD frequency at 16 MHz or less.
2. With using the sample and hold function

Table 5.9 D/A Conversion Characteristics
(VCC1 = VCC2 = VREF = 4.2 to 5.5 V, VSS = AVSS = 0 V, Topr = -20 to 85°C, f(CPU) = 32MHz unless otherwise specified)

Symbol	Parameter	Measurement Condition	Standard			Unit
			Min.	Typ.	Max.	
–	Resolution				8	Bits
–	Absolute accuracy				1.0	%
tsu	Setup time				3	μs
RO	Output resistance		4	10	20	kΩ
IVREF	Reference power supply input current	(note 1)			1.5	mA

NOTE:

1. Measured when one D/A converter is used, and the DAi register (i = 0, 1) of the unused D/A converter is set to 00h. The current flow into the resistor ladder in the A/D converter is excluded. IVREF flows even if the VCUT bit in the AD0CON1 register is set to 0 (VREF not connected)

$$VCC1 = VCC2 = 5V$$

Table 5.10 Voltage Detection Circuit Electrical Characteristics
($VCC1 = VCC2 = 3.0$ to 5.5 V, $VSS = 0$ V, $Topr = 25^{\circ}C$ unless otherwise specified)

Symbol	Parameter	Standard			Unit	
		Min.	Typ.	Max.		
Vdet4	Vdet4 detection voltage	VCC1 = 3.0 V to 5.5 V	3.3	3.8	4.4	V
Vdet3	Vdet3 detection voltage			3.0		V
Vdet3s	Hardware reset 2 hold voltage				2.0	V
Vdet3r	Hardware reset 2 release voltage			3.1		V

NOTES:

1. $Vdet4 > Vdet3$
2. $Vdet3r > Vdet3$ is not guaranteed.

Table 5.11 Power Supply Timing Characteristics

Symbol	Parameter	Measurement Condition	Standard			Unit
			Min.	Typ.	Max.	
td(P-R)	Wait time to stabilize internal supply voltage when power-on	$VCC1 = 3.0$ to 5.5 V			2	ms
td(S-R)	Wait time to release hardware reset 2	$VCC1 = Vdet3r$ to 5.5 V		6 ⁽¹⁾	20	ms
td(E-A)	Start-up time for Vdet3 and Vdet4 detection circuit	$VCC1 = 3.0$ to 5.5 V			20	μs

NOTE:

1. When $VCC1 = 5$ V

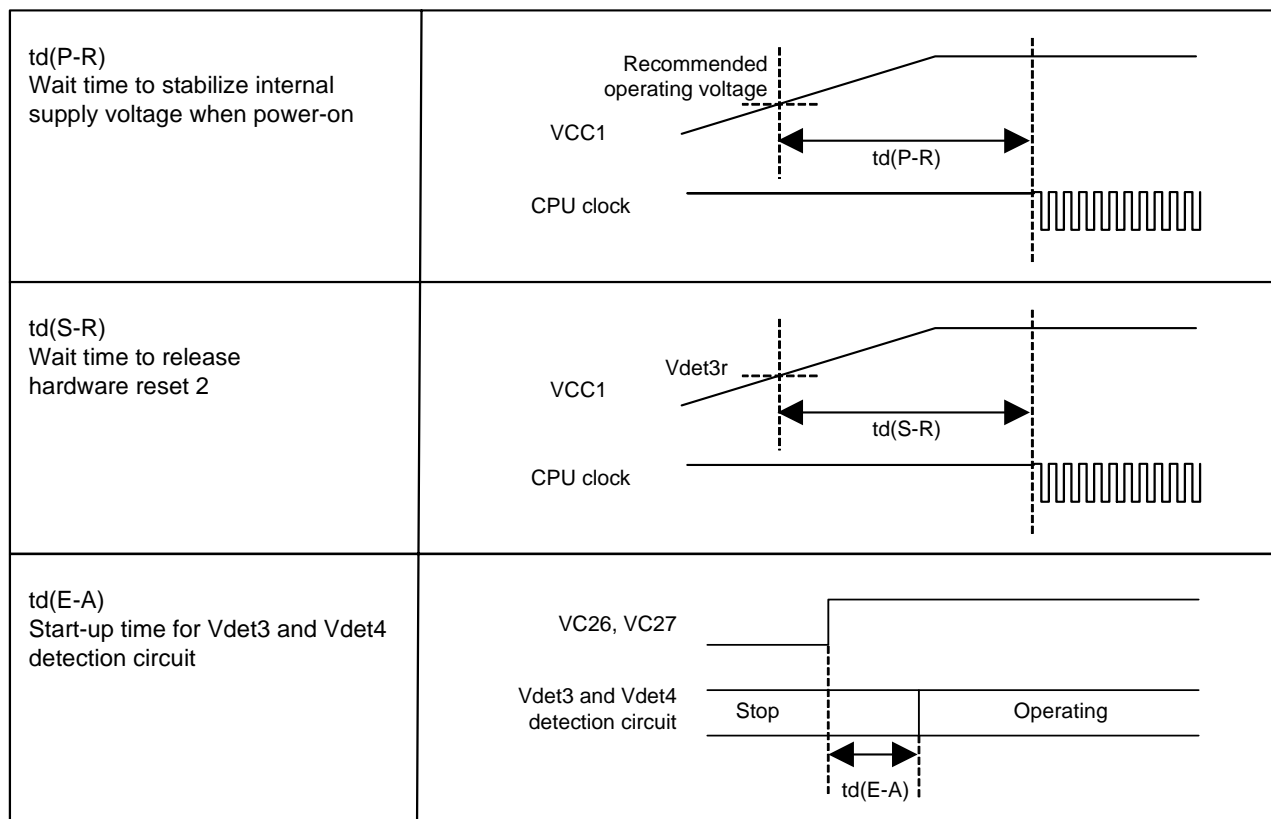

Figure 5.1 Power Supply Timing Diagram

$$VCC1 = VCC2 = 5V$$

Timing Requirements

(VCC1 = VCC2 = 4.2 to 5.5 V, VSS = 0 V, Topr = -20 to 85°C unless otherwise specified)

Table 5.12 External Clock Input

Symbol	Parameter	Standard		Unit
		Min.	Max.	
tc	External clock input cycle time	31.25		ns
tw(H)	External clock input high ("H") pulse width	13.75		ns
tw(L)	External clock input low ("L") pulse width	13.75		ns
tr	External clock rise time		5	ns
tf	External clock fall time		5	ns

Table 5.13 Timer A Input (Count Source Input in Event Counter Mode)

Symbol	Parameter	Standard		Unit
		Min.	Max.	
tc(TA)	TAiIN input cycle time	100		ns
tw(TAH)	TAiIN input high ("H") pulse width	40		ns
tw(TAL)	TAiIN input low ("L") pulse width	40		ns

i = 0 to 4

Table 5.14 Timer A Input (Gate Signal Input in Timer Mode)

Symbol	Parameter	Standard		Unit
		Min.	Max.	
tc(TA)	TAiIN input cycle time	400		ns
tw(TAH)	TAiIN input high ("H") pulse width	200		ns
tw(TAL)	TAiIN input low ("L") pulse width	200		ns

i = 0 to 4

Table 5.15 Timer A Input (External Trigger Input in One-Shot Timer Mode)

Symbol	Parameter	Standard		Unit
		Min.	Max.	
tc(TA)	TAiIN input cycle time	200		ns
tw(TAH)	TAiIN input high ("H") pulse width	100		ns
tw(TAL)	TAiIN input low ("L") pulse width	100		ns

i = 0 to 4

Table 5.16 Timer A Input (External Trigger Input in Pulse Width Modulation Mode)

Symbol	Parameter	Standard		Unit
		Min.	Max.	
tw(TAH)	TAiIN input high ("H") pulse width	100		ns
tw(TAL)	TAiIN input low ("L") pulse width	100		ns

i = 0 to 4

$$VCC1 = VCC2 = 5V$$

Timing Requirements

(VCC1 = VCC2 = 4.2 to 5.5 V, VSS = 0 V, Topr = -20 to 85°C unless otherwise specified)

Table 5.17 Timer A Input (Counter Increment/Decrement Input in Event Counter Mode)

Symbol	Parameter	Standard		Unit
		Min.	Max.	
tc(UP)	TAiOUT input cycle time	2000		ns
tw(UPH)	TAiOUT input high ("H") pulse width	1000		ns
tw(UPL)	TAiOUT input low ("L") pulse width	1000		ns
tsu(UP-TIN)	TAiOUT input setup time	400		ns
th(TIN-UP)	TAiOUT input hold time	400		ns

i = 0 to 4

Table 5.18 Timer A Input (Two-Phase Pulse Input in Event Counter Mode)

Symbol	Parameter	Standard		Unit
		Min.	Max.	
tc(TA)	TAiIN input cycle time	800		ns
tsu(TAIN-TAOUT)	TAiOUT input setup time	200		ns
tsu(TAOUT-TAIN)	TAiIN input setup time	200		ns

i = 0 to 4

Table 5.19 Timer B Input (Count Source Input in Event Counter Mode)

Symbol	Parameter	Standard		Unit
		Min.	Max.	
tc(TB)	TBiIN input cycle time (counted on one edge)	100		ns
tw(TBH)	TBiIN input high ("H") pulse width (counted on one edge)	40		ns
tw(TBL)	TBiIN input low ("L") pulse width (counted on one edge)	40		ns
tc(TB)	TBiIN input cycle time (counted on both edges)	200		ns
tw(TBH)	TBiIN input high ("H") pulse width (counted on both edges)	80		ns
tw(TBL)	TBiIN input low ("L") pulse width (counted on both edges)	80		ns

i = 0 to 5

Table 5.20 Timer B Input (Pulse Period Measurement Mode)

Symbol	Parameter	Standard		Unit
		Min.	Max.	
tc(TB)	TBiIN input cycle time	400		ns
tw(TBH)	TBiIN input high ("H") pulse width	200		ns
tw(TBL)	TBiIN input low ("L") pulse width	200		ns

i = 0 to 5

Table 5.21 Timer B Input (Pulse Width Measurement Mode)

Symbol	Parameter	Standard		Unit
		Min.	Max.	
tc(TB)	TBiIN input cycle time	400		ns
tw(TBH)	TBiIN input high ("H") pulse width	200		ns
tw(TBL)	TBiIN input low ("L") pulse width	200		ns

i = 0 to 5

$$VCC1 = VCC2 = 5V$$

Timing Requirements

(VCC1 = VCC2 = 4.2 to 5.5 V, VSS = 0 V, Topr = -20 to 85°C unless otherwise specified)

Table 5.22 A/D Trigger Input

Symbol	Parameter	Standard		Unit
		Min.	Max.	
tc(AD)	$\overline{\text{ADTRG}}$ input cycle time (required for trigger)	1000		ns
tw(ADL)	$\overline{\text{ADTRG}}$ input low ("L") pulse width	125		ns

Table 5.23 Serial Interface

Symbol	Parameter	Standard		Unit
		Min.	Max.	
tc(CK)	CLKi input cycle time	200		ns
tw(CKH)	CLKi input high ("H") pulse width	100		ns
tw(CKL)	CLKi input low ("L") pulse width	100		ns
td(C-Q)	TXDi output delay time		80	ns
th(C-Q)	TXDi output hold time	0		ns
tsu(D-C)	RXDi input setup time	30		ns
th(C-D)	RXDi input hold time	90		ns

i=0 to 4

Table 5.24 External Interrupt $\overline{\text{INTi}}$ Input (Edge Sensitive)

Symbol	Parameter	Standard		Unit
		Min.	Max.	
tw(INH)	$\overline{\text{INTi}}$ input high ("H") pulse width	250		ns
tw(INL)	$\overline{\text{INTi}}$ input low ("L") pulse width	250		ns

i=0 to 5

$$VCC1 = VCC2 = 5V$$

Timing Requirements

(VCC1 = VCC2 = 4.2 to 5.5 V, VSS = 0 V, Topr = -20 to 85°C unless otherwise specified)

Table 5.25 Microprocessor Mode

Symbol	Parameter	Standard		Unit
		Min.	Max.	
tac1(RD-DB)	Data input access time (RD standard)		(note 1)	ns
tac1(AD-DB)	Data input access time (AD standard, CS standard)		(note 1)	ns
tac2(RD-DB)	Data input access time (RD standard, when accessing a space with the multiplexed bus)		(note 1)	ns
tac2(AD-DB)	Data input access time (AD standard, when accessing a space with the multiplexed bus)		(note 1)	ns
tsu(DB-BCLK)	Data input setup time	26		ns
tsu(RDY-BCLK)	$\overline{\text{RDY}}$ input setup time	26		ns
tsu(HOLD-BCLK)	$\overline{\text{HOLD}}$ input setup time	30		ns
th(RD-DB)	Data input hold time	0		ns
th(BCLK-RDY)	$\overline{\text{RDY}}$ input hold time	0		ns
th(BCLK-HOLD)	$\overline{\text{HOLD}}$ input hold time	0		ns
td(BCLK-HLDA)	$\overline{\text{HLDA}}$ output delay time		25	ns

NOTE:

- Values, which depend on BCLK frequency and external bus cycles, can be obtained from the following equations. Insert wait states or lower the operation frequency, $f(\text{BCLK})$, if the calculated value is negative.

$$tac1(\text{RD-DB}) = \frac{10^9 \times m}{f(\text{BCLK}) \times 2} - 35 \text{ [ns]} \text{ (if external bus cycle is } a\phi + b\phi, m = (b \times 2) + 1)$$

$$tac1(\text{AD-DB}) = \frac{10^9 \times n}{f(\text{BCLK})} - 35 \text{ [ns]} \text{ (if external bus cycle is } a\phi + b\phi, n = a + b)$$

$$tac2(\text{RD-DB}) = \frac{10^9 \times m}{f(\text{BCLK}) \times 2} - 35 \text{ [ns]} \text{ (if external bus cycle is } a\phi + b\phi, m = (b \times 2) - 1)$$

$$tac2(\text{AD-DB}) = \frac{10^9 \times p}{f(\text{BCLK}) \times 2} - 35 \text{ [ns]} \text{ (if external bus cycle is } a\phi + b\phi, p = \{(a + b - 1) \times 2\} + 1)$$

$$VCC1 = VCC2 = 5V$$

Switching Characteristics

(VCC1 = VCC2 = 4.2 to 5.5 V, VSS = 0 V, Topr = -20 to 85°C unless otherwise specified)

Table 5.26 Microprocessor Mode (when accessing external memory space)

Symbol	Parameter	Measurement Condition	Standard		Unit
			Min.	Max.	
td(BCLK-AD)	Address output delay time	See Figure 5.2		18	ns
th(BCLK-AD)	Address output hold time (BCLK standard)		-3		ns
th(RD-AD)	Address output hold time (RD standard) ⁽³⁾		0		ns
th(WR-AD)	Address output hold time (WR standard) ⁽³⁾		(note 1)		ns
td(BCLK-CS)	Chip-select signal output delay time			18	ns
th(BCLK-CS)	Chip-select signal output hold time (BCLK standard)		-3		ns
th(RD-CS)	Chip-select signal output hold time (RD standard) ⁽³⁾		0		ns
th(WR-CS)	Chip-select signal output hold time (WR standard) ⁽³⁾		(note 1)		ns
td(BCLK-RD)	RD signal output delay time			18	ns
th(BCLK-RD)	RD signal output hold time		-5		ns
td(BCLK-WR)	WR signal output delay time			18	ns
th(BCLK-WR)	WR signal output hold time		-5		ns
td(DB-WR)	Data output delay time (WR standard)		(note 2)		ns
th(WR-DB)	Data output hold time (WR standard) ⁽³⁾		(note 1)		ns
tw(WR)	WR output width		(note 2)		ns

NOTES:

- Values, which depend on BCLK frequency, can be obtained from the following equations.

$$th(WR-DB) = \frac{10^9}{f(BCLK) \times 2} - 10 \text{ [ns]}$$

$$th(WR-AD) = \frac{10^9}{f(BCLK) \times 2} - 10 \text{ [ns]}$$

$$th(WR-CS) = \frac{10^9}{f(BCLK) \times 2} - 10 \text{ [ns]}$$

- Values, which depend on BCLK frequency and external bus cycles, can be obtained from the following equations.

$$td(DB-WR) = \frac{10^9 \times m}{f(BCLK)} - 20 \text{ [ns]} \text{ (if external bus cycle is } a\phi + b\phi, m = b)$$

$$tw(WR) = \frac{10^9 \times n}{f(BCLK) \times 2} - 15 \text{ [ns]} \text{ (if external bus cycle is } a\phi + b\phi, n = (b \times 2) - 1)$$

- tc [ns] is added when recovery cycle is inserted.

$$VCC1 = VCC2 = 5V$$

Switching Characteristics

(VCC1 = VCC2 = 4.2 to 5.5 V, VSS = 0 V, Topr = -20 to 85°C unless otherwise specified)

Table 5.27 Microprocessor Mode (when accessing external memory space with multiplexed bus)

Symbol	Parameter	Measurement Condition	Standard		Unit
			Min.	Max.	
td(BCLK-AD)	Address output delay time	See Figure 5.2		18	ns
th(BCLK-AD)	Address output hold time (BCLK standard)		-3		ns
th(RD-AD)	Address output hold time (RD standard) ⁽⁵⁾		(note 1)		ns
th(WR-AD)	Address output hold time (WR standard) ⁽⁵⁾		(note 1)		ns
td(BCLK-CS)	Chip-select signal output delay time			18	ns
th(BCLK-CS)	Chip-select signal output hold time (BCLK standard)		-3		ns
th(RD-CS)	Chip-select signal output hold time (RD standard) ⁽⁵⁾		(note 1)		ns
th(WR-CS)	Chip-select signal output hold time (WR standard) ⁽⁵⁾		(note 1)		ns
td(BCLK-RD)	RD signal output delay time			18	ns
th(BCLK-RD)	RD signal output hold time		-5		ns
td(BCLK-WR)	WR signal output delay time			18	ns
th(BCLK-WR)	WR signal output hold time		-5		ns
td(DB-WR)	Data output delay time (WR standard)		(note 2)		ns
th(WR-DB)	Data output hold time (WR standard) ⁽⁵⁾		(note 1)		ns
td(BCLK-ALE)	ALE signal output delay time (BCLK standard)			18	ns
th(BCLK-ALE)	ALE signal output hold time (BCLK standard)		-2		ns
td(AD-ALE)	ALE signal output delay time (address standard)		(note 3)		ns
th(ALE-AD)	ALE signal output hold time (address standard)		(note 4)		ns
tdz(RD-AD)	Address output float start time			8	ns

NOTES:

1. Values, which depend on BCLK frequency, can be obtained from the following equations.

$$th(RD-AD) = \frac{10^9}{f(BCLK) \times 2} - 10 \text{ [ns]}$$

$$th(WR-AD) = \frac{10^9}{f(BCLK) \times 2} - 10 \text{ [ns]}$$

$$th(RD-CS) = \frac{10^9}{f(BCLK) \times 2} - 10 \text{ [ns]}$$

$$th(WR-CS) = \frac{10^9}{f(BCLK) \times 2} - 10 \text{ [ns]}$$

$$th(WR-DB) = \frac{10^9}{f(BCLK) \times 2} - 10 \text{ [ns]}$$

2. Values, which depend on BCLK frequency and external bus cycles, can be obtained from the following equation.

$$td(DB-WR) = \frac{10^9 \times m}{f(BCLK) \times 2} - 25 \text{ [ns]} \text{ (if external bus cycle is } a\phi + b\phi, m = (b \times 2) - 1)$$

3. Values, which depend on BCLK frequency and external bus cycles, can be obtained from the following equation.

$$td(AD-ALE) = \frac{10^9 \times n}{f(BCLK) \times 2} - 20 \text{ [ns]} \text{ (if external bus cycle is } a\phi + b\phi, n = a)$$

4. Values, which depend on BCLK frequency and external bus cycles, can be obtained from the following equation.

$$th(ALE-AD) = \frac{10^9 \times n}{f(BCLK) \times 2} - 10 \text{ [ns]} \text{ (if external bus cycle is } a\phi + b\phi, n = a)$$

5. tc [ns] is added when recovery cycle is inserted.

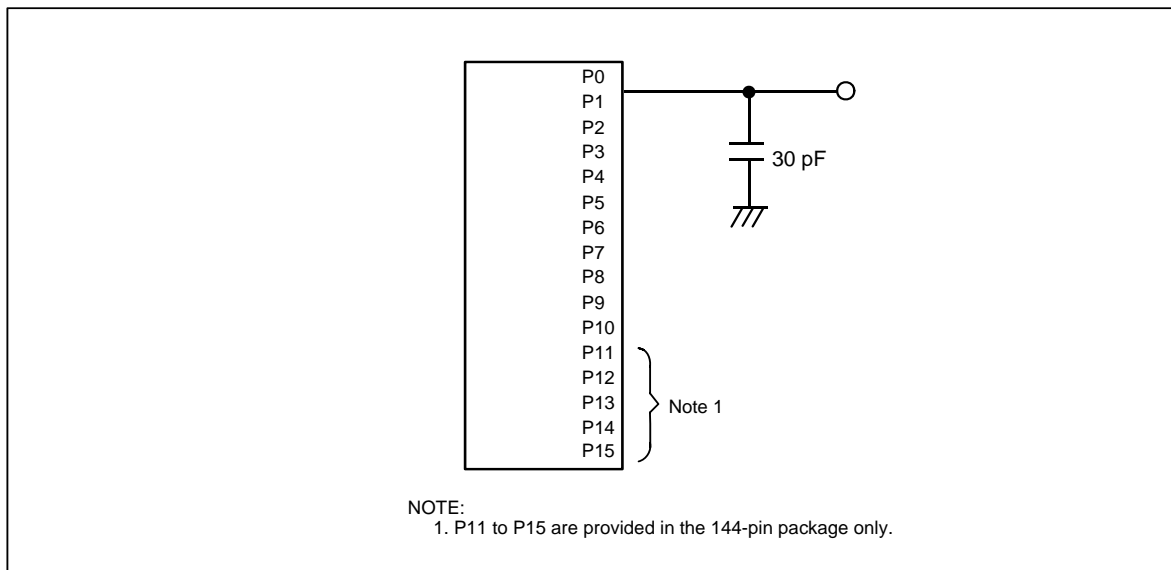

Figure 5.2 P0 to P15 Measurement Circuit

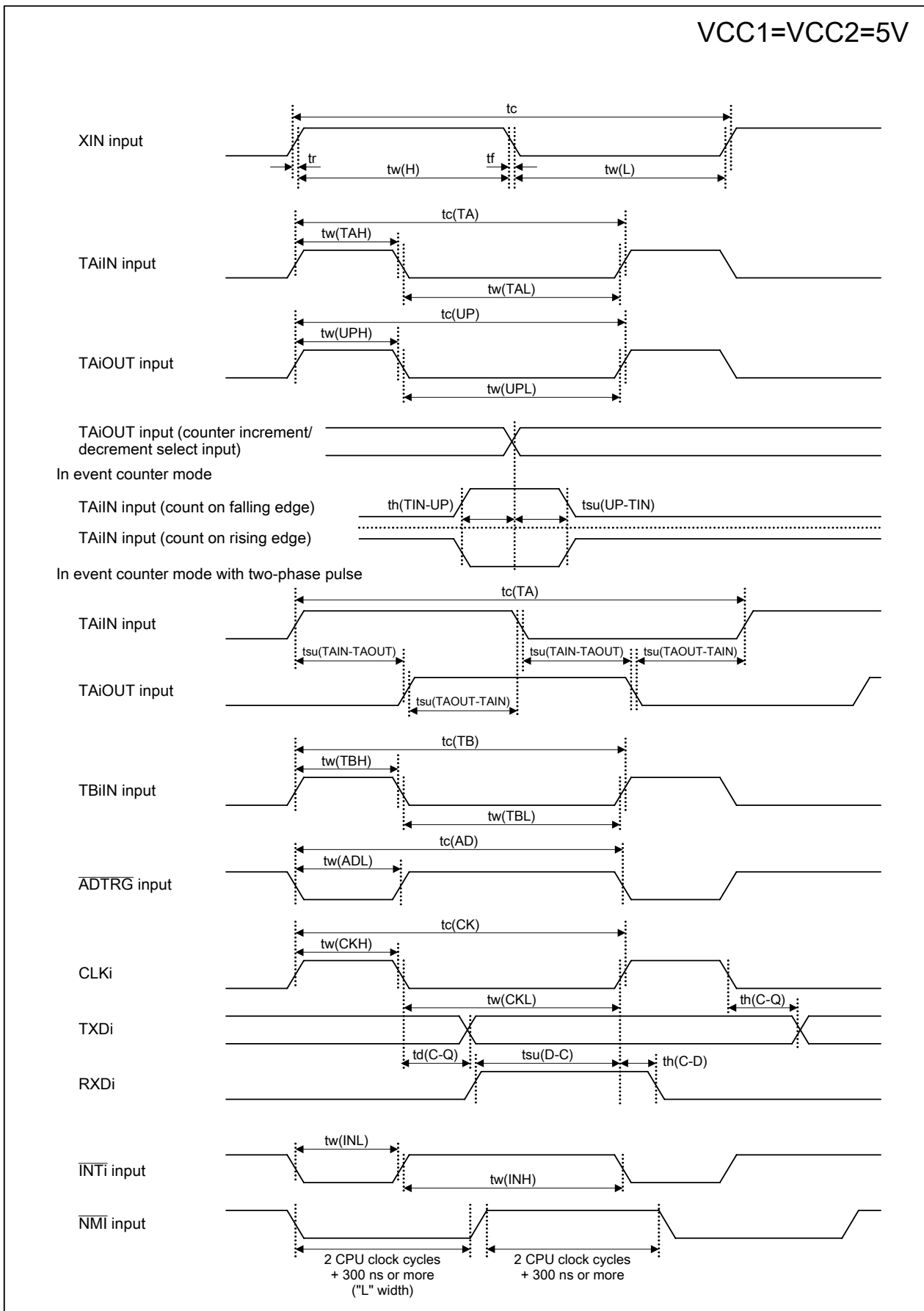

Figure 5.3 VCC1 = VCC2 = 5 V Timing Diagram (1)

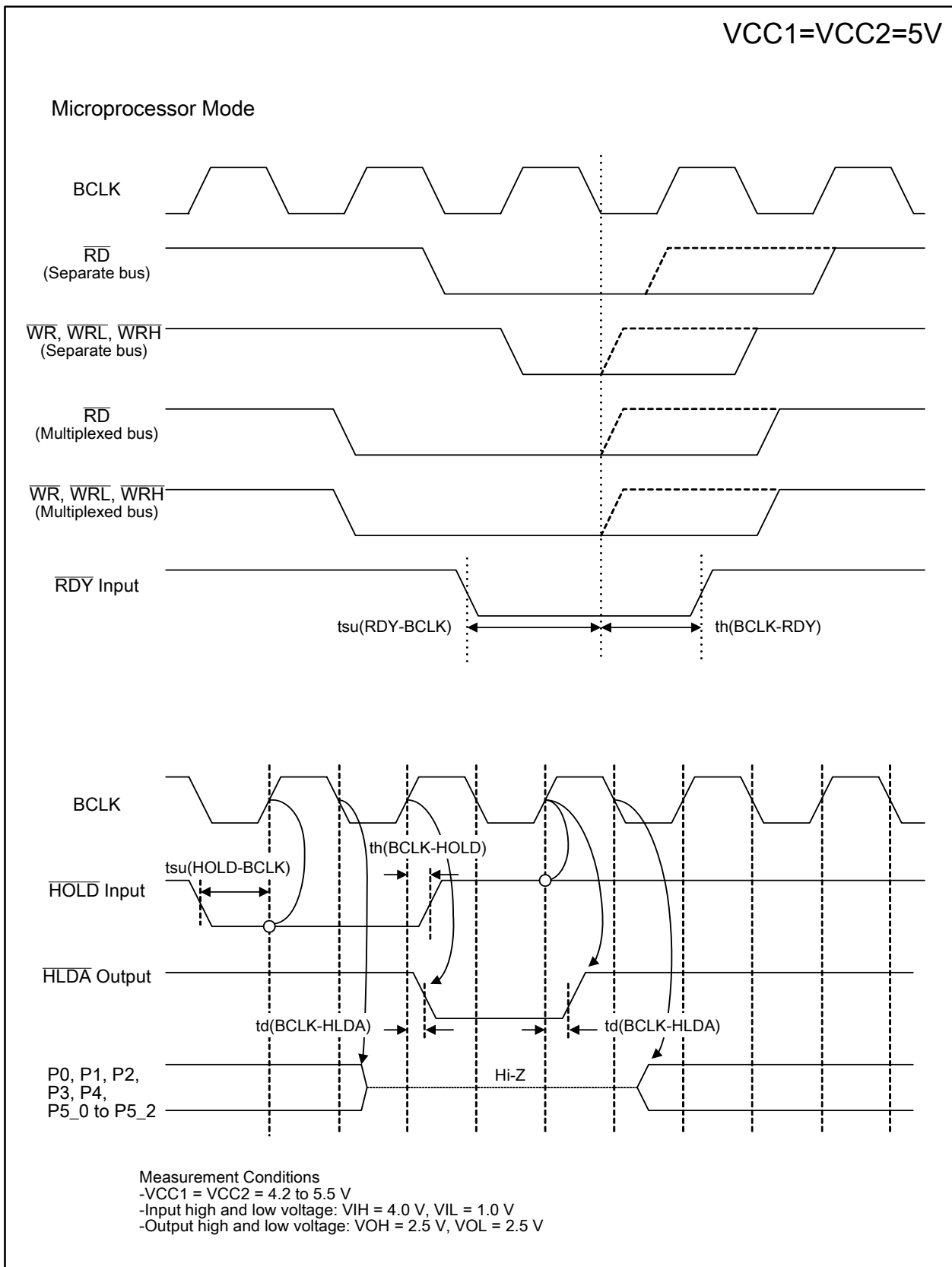

Figure 5.4 VCC1 = VCC2 = 5 V Timing Diagram (2)

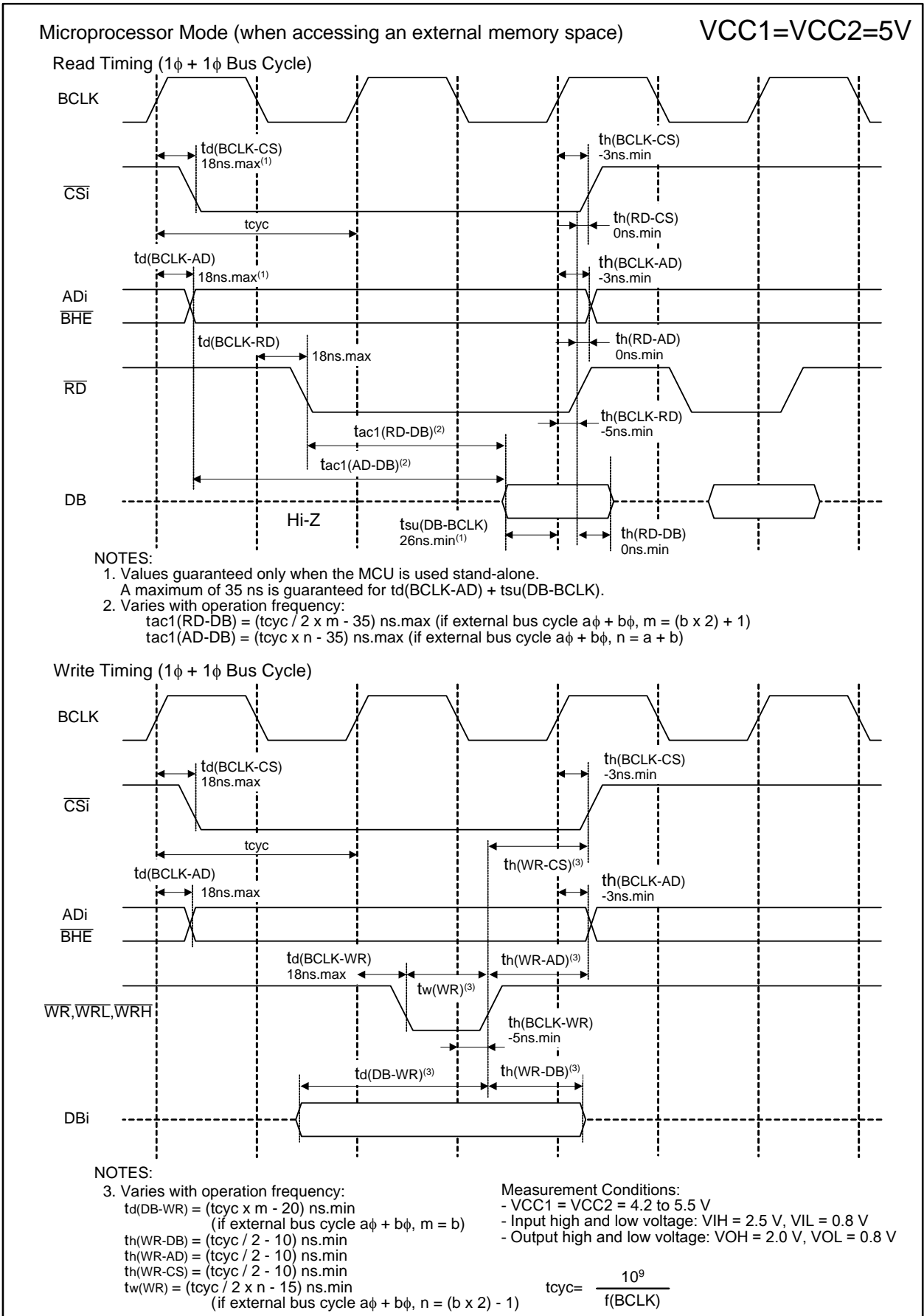

Figure 5.5 VCC1 = VCC2 = 5 V Timing Diagram (3)

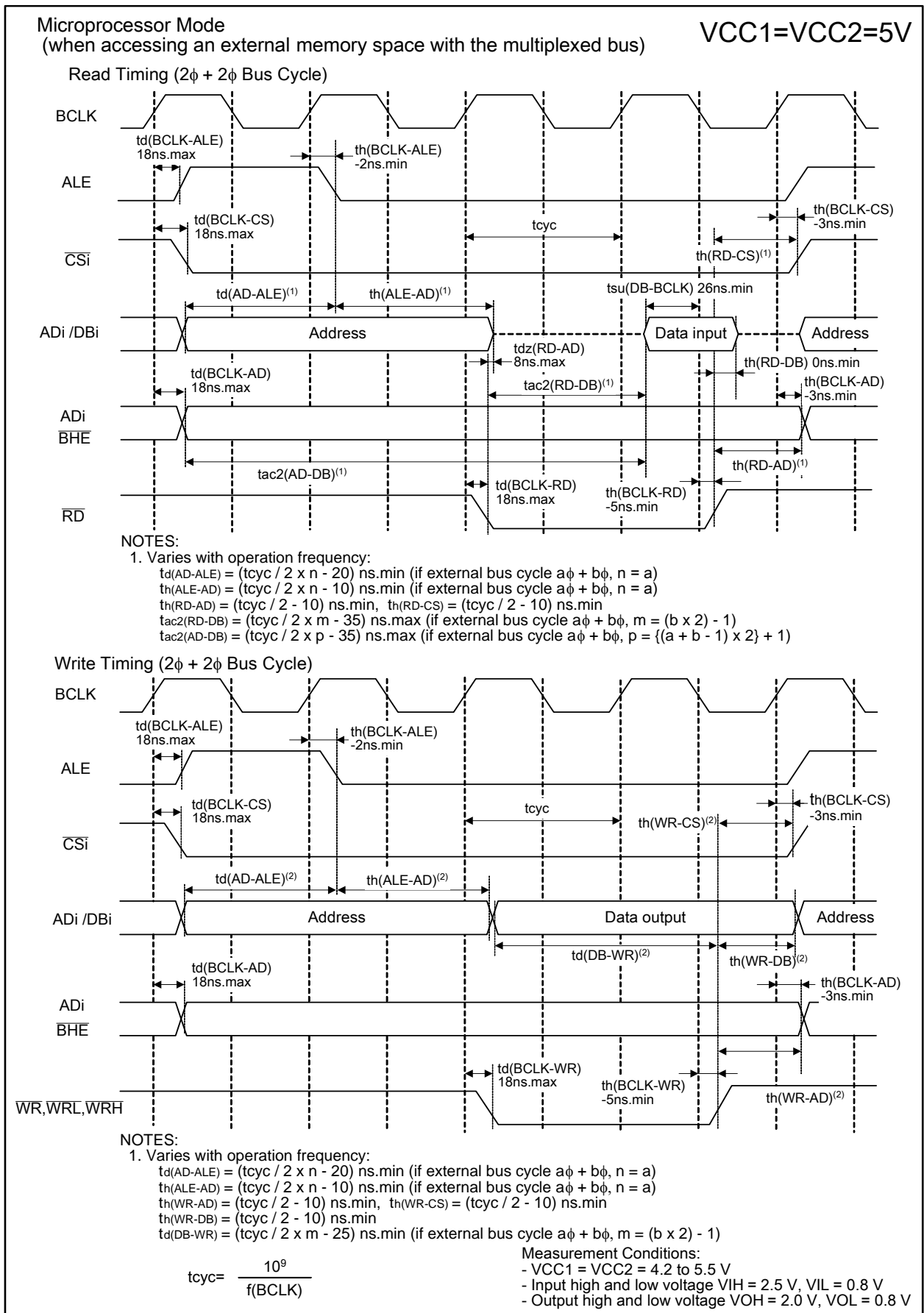

Figure 5.6 VCC1 = VCC2 = 5 V Timing Diagram (4)

$$VCC1 = VCC2 = 3.3 \text{ V}$$

Table 5.28 Electrical Characteristics (1)

(VCC1 = VCC2 = 3.0 to 3.6 V, VSS = 0 V, Topr = -20 to 85°C, f(CPU) = 24 MHz unless otherwise specified)

Symbol	Parameter		Condition	Standard			Unit	
				Min.	Typ.	Max.		
VOH	Output high "H" voltage	P0_0 to P0_7, P1_0 to P1_7, P2_0 to P2_7, P3_0 to P3_7, P4_0 to P4_7, P5_0 to P5_7, P11_0 to P11_4, P12_0 to P12_7, P13_0 to P13_7 ⁽¹⁾	IOH = -1 mA	VCC2 - 0.6		VCC2	V	
		P6_0 to P6_7, P7_2 to P7_7, P8_0 to P8_4, P8_6, P8_7, P9_0 to P9_7, P10_0 to P10_7, P14_0 to P14_6, P15_0 to P15_7 ⁽¹⁾		VCC1 - 0.6		VCC1		
	XOUT	IOH = -0.1 mA	2.7		VCC1	V		
	XCOUT	High drive capability	No load applied		2.5		V	
		Low drive capability	No load applied		1.6		V	
VOL	Output low "L" voltage	P0_0 to P0_7, P1_0 to P1_7, P2_0 to P2_7, P3_0 to P3_7, P4_0 to P4_7, P5_0 to P5_7, P6_0 to P6_7, P7_0 to P7_7, P8_0 to P8_4, P8_6, P8_7, P9_0 to P9_7, P10_0 to P10_7, P11_0 to P11_4, P12_0 to P12_7, P13_0 to P13_7, P14_0 to P14_6, P15_0 to P15_7 ⁽¹⁾	IOL = 1 mA			0.5	V	
		XOUT		IOL = 0.1 mA				0.5
		XCOUT	High drive capability	No load applied		0		V
			Low drive capability	No load applied		0		V
VT+ - VT-	Hysteresis	$\overline{\text{HOLD}}$, $\overline{\text{RDY}}$, TA0IN to TA4IN, TB0IN to TB5IN, INT0 to INT5, ADTRG, CTS0 to CTS4, CLK0 to CLK4, TA0OUT to TA4OUT, NMI, $\overline{\text{KI0}}$ to $\overline{\text{KI3}}$, RXD0 to RXD4, SCL0 to SCL4, SDA0 to SDA4		0.2		1.0	V	
		$\overline{\text{RESET}}$		0.2		1.8	V	

NOTE:

1. P11 to P15 are provided in the 144-pin package only.

$$VCC1 = VCC2 = 3.3 V$$

Table 5.29 Electrical Characteristics (2)
(VCC1 = VCC2 = 3.0 to 3.6 V, VSS = 0 V, Topr = -20 to 85°C, f(CPU) = 24 MHz unless otherwise specified)

Symbol	Parameter		Condition	Standard			Unit
				Min.	Typ.	Max.	
I _{IH}	Input high "H" current	P0_0 to P0_7, P1_0 to P1_7, P2_0 to P2_7, P3_0 to P3_7, P4_0 to P4_7, P5_0 to P5_7, P6_0 to P6_7, P7_0 to P7_7, P8_0 to P8_7, P9_0 to P9_7, P10_0 to P10_7, P11_0 to P11_4, P12_0 to P12_7, P13_0 to P13_7, P14_0 to P14_6, P15_0 to P15_7 ⁽¹⁾ , XIN, RESET, CNVSS, BYTE	V _I = 3 V			4.0	μA
I _{IL}	Input low "L" current	P0_0 to P0_7, P1_0 to P1_7, P2_0 to P2_7, P3_0 to P3_7, P4_0 to P4_7, P5_0 to P5_7, P6_0 to P6_7, P7_0 to P7_7, P8_0 to P8_7, P9_0 to P9_7, P10_0 to P10_7, P11_0 to P11_4, P12_0 to P12_7, P13_0 to P13_7, P14_0 to P14_6, P15_0 to P15_7 ⁽¹⁾ , XIN, RESET, CNVSS, BYTE	V _I = 0V			-4.0	μA
RPULLUP	Pull-up resistance	P0_0 to P0_7, P1_0 to P1_7, P2_0 to P2_7, P3_0 to P3_7, P4_0 to P4_7, P5_0 to P5_7, P6_0 to P6_7, P7_2 to P7_7, P8_0 to P8_4, P8_6, P8_7, P9_0 to P9_7, P10_0 to P10_7, P11_0 to P11_4, P12_0 to P12_7, P13_0 to P13_7, P14_0 to P14_6, P15_0 to P15_7 ⁽¹⁾	V _I =0V	40	70	500	kΩ
R _{fXIN}	Feedback resistance	XIN			3.0		MΩ
R _{fXCIN}	Feedback resistance	XCIN			20.0		MΩ
VRAM	RAM data retention voltage	In stop mode		2.0			V

NOTE:

1. P11 to P15 are provided in the 144-pin package only.

Table 5.30 Electrical Characteristics (3) (VCC1 = VCC2 = 3.3 V, VSS = 0 V, Topr = 25°C)

Symbol	Parameter	Condition		Standard			Unit
				Min.	Typ.	Max.	
ICC	Power supply current	ROMless version	f(CPU) = 24 MHz		22	33	mA
			f(CPU) = 16 MHz		15		mA
			f(CPU) = 8 MHz		9		mA
			f(CPU) = f(Ring) In on-chip oscillator low-power consumption mode		1		mA
			f(CPU) = 32 kHz In low-power consumption mode		25		μA
			f(CPU) = f(Ring) After entering wait mode from on-chip oscillator low-power consumption mode		45		μA
			Stop mode (while clock is stopped)		0.8	5	μA
			Stop mode (while clock is stopped) Topr = 85°C			50	μA

$$VCC1 = VCC2 = 3.3 V$$

Table 5.31 A/D Conversion Characteristics
(VCC1 = VCC2 = AVCC = VREF = 3.0 to 3.6 V, VSS = AVSS = 0 V, Topr = -20 to 85°C,
f(CPU) = 24MHz unless otherwise specified)

Symbol	Parameter	Measurement Condition	Standard			Unit
			Min.	Typ.	Max.	
–	Resolution	VREF = VCC1			10	Bits
INL	Integral nonlinearity error (8-bit)	VREF = VCC1 = VCC2 = 3.3 V			±2	LSB
DNL	Differential nonlinearity error (8-bit)				±1	LSB
–	Offset error (8-bit)				±2	LSB
–	Gain error (8-bit)				±2	LSB
RLADDER	Resistor ladder	VREF = VCC1	8		40	kΩ
tCONV	8-bit conversion time ⁽¹⁾⁽²⁾		4.9			μs
VREF	Reference voltage		3		VCC1	V
VIA	Analog input voltage		0		VREF	V

NOTES:

- The value when φAD frequency is at 10 MHz. Keep φAD frequency at 10 MHz or less.
If f(CPU) (=fAD) is 24 MHz, divide f(CPU) by 3 to make it 8 MHz. The conversion time in this case is 6.1 μs.
- S&H not available.

Table 5.32 D/A Conversion Characteristics
(VCC1 = VCC2 = VREF = 3.0 to 3.6 V, VSS = AVSS = 0 V at Topr = -20 to 85°C,
f(CPU) = 24MHz unless otherwise specified)

Symbol	Parameter	Measurement Condition	Standard			Unit
			Min.	Typ.	Max.	
–	Resolution				8	Bits
–	Absolute accuracy				1.0	%
tsu	Setup time				3	μs
RO	Output resistance		4	10	20	kΩ
IVREF	Reference power supply input current	(note 1)			1.0	mA

NOTE:

- Measurement when one D/A converter is used, and the DAi register (i = 0, 1) of the unused D/A converter is set to 00h. The current flown into the resistor ladder in the A/D converter is excluded. IVREF flows even if VCUT bit in the AD0CON1 register is set to 0 (VREF not connected)

$$VCC1 = VCC2 = 3.3 V$$

Timing Requirements

(VCC1 = VCC2 = 3.0 to 3.6 V, VSS = 0 V, Topr = -20 to 85°C unless otherwise specified)

Table 5.33 External Clock Input

Symbol	Parameter	Standard		Unit
		Min.	Max.	
tc	External clock input cycle time	41		ns
tw(H)	External clock input high ("H") pulse width	18		ns
tw(L)	External clock input low ("L") pulse width	18		ns
tr	External clock rise time		5	ns
tf	External clock fall time		5	ns

Table 5.34 Timer A Input (Count Source Input in Event Counter Mode)

Symbol	Parameter	Standard		Unit
		Min.	Max.	
tc(TA)	TAiIN input cycle time	100		ns
tw(TAH)	TAiIN input high ("H") pulse width	40		ns
tw(TAL)	TAiIN input low ("L") pulse width	40		ns

i = 0 to 4

Table 5.35 Timer A Input (Gate Signal Input in Timer Mode)

Symbol	Parameter	Standard		Unit
		Min.	Max.	
tc(TA)	TAiIN input cycle time	400		ns
tw(TAH)	TAiIN input high ("H") pulse width	200		ns
tw(TAL)	TAiIN input low ("L") pulse width	200		ns

i = 0 to 4

Table 5.36 Timer A Input (External Trigger Input in One-Shot Timer Mode)

Symbol	Parameter	Standard		Unit
		Min.	Max.	
tc(TA)	TAiIN input cycle time	200		ns
tw(TAH)	TAiIN input high ("H") pulse width	100		ns
tw(TAL)	TAiIN input low ("L") pulse width	100		ns

i = 0 to 4

Table 5.37 Timer A Input (External Trigger Input in Pulse Width Modulation Mode)

Symbol	Parameter	Standard		Unit
		Min.	Max.	
tw(TAH)	TAiIN input high ("H") pulse width	100		ns
tw(TAL)	TAiIN input low ("L") pulse width	100		ns

i = 0 to 4

$$VCC1 = VCC2 = 3.3 V$$

Timing Requirements

(VCC1 = VCC2 = 3.0 to 3.6 V, VSS = 0 V, Topr = -20 to 85°C unless otherwise specified)

Table 5.38 Timer A Input (Counter Increment/Decrement Input in Event Counter Mode)

Symbol	Parameter	Standard		Unit
		Min.	Max.	
tc(UP)	TAiOUT input cycle time	2000		ns
tw(UPH)	TAiOUT input high ("H") pulse width	1000		ns
tw(UPL)	TAiOUT input low ("L") pulse width	1000		ns
tsu(UP-TIN)	TAiOUT input setup time	400		ns
th(TIN-UP)	TAiOUT input hold time	400		ns

i = 0 to 4

Table 5.39 Timer A Input (Two-Phase Pulse Input in Event Counter Mode)

Symbol	Parameter	Standard		Unit
		Min.	Max.	
tc(TA)	TAiIN input cycle time	2		μs
tsu(TAIN-TAOUT)	TAiOUT input setup time	500		ns
tsu(TAOUT-TAIN)	TAiIN input setup time	500		ns

i = 0 to 4

Table 5.40 Timer B Input (Count Source Input in Event Counter Mode)

Symbol	Parameter	Standard		Unit
		Min.	Max.	
tc(TB)	TBiIN input cycle time (counted on one edge)	100		ns
tw(TBH)	TBiIN input high ("H") pulse width (counted on one edge)	40		ns
tw(TBL)	TBiIN input low ("L") pulse width (counted on one edge)	40		ns
tc(TB)	TBiIN input cycle time (counted on both edges)	200		ns
tw(TBH)	TBiIN input high ("H") pulse width (counted on both edges)	80		ns
tw(TBL)	TBiIN input low ("L") pulse width (counted on both edges)	80		ns

i = 0 to 5

Table 5.41 Timer B Input (Pulse Period Measurement Mode)

Symbol	Parameter	Standard		Unit
		Min.	Max.	
tc(TB)	TBiIN input cycle time	400		ns
tw(TBH)	TBiIN input high ("H") pulse width	200		ns
tw(TBL)	TBiIN input low ("L") pulse width	200		ns

i = 0 to 5

Table 5.42 Timer B Input (Pulse Width Measurement Mode)

Symbol	Parameter	Standard		Unit
		Min.	Max.	
tc(TB)	TBiIN input cycle time	400		ns
tw(TBH)	TBiIN input high ("H") pulse width	200		ns
tw(TBL)	TBiIN input low ("L") pulse width	200		ns

i = 0 to 5

$$VCC1 = VCC2 = 3.3 V$$

Timing Requirements

(VCC1 = VCC2 = 3.0 to 3.6 V, VSS = 0 V, Topr = -20 to 85°C unless otherwise specified)

Table 5.43 A/D Trigger Input

Symbol	Parameter	Standard		Unit
		Min.	Max.	
tc(AD)	\overline{ADTRG} input cycle time (required for trigger)	1000		ns
tw(ADL)	\overline{ADTRG} input low ("L") pulse width	125		ns

Table 5.44 Serial Interface

Symbol	Parameter	Standard		Unit
		Min.	Max.	
tc(CK)	CLKi input cycle time	200		ns
tw(CKH)	CLKi input high ("H") pulse width	100		ns
tw(CKL)	CLKi input low ("L") pulse width	100		ns
td(C-Q)	TXDi output delay time		80	ns
th(C-Q)	TXDi output hold time	0		ns
tsu(D-C)	RXDi input setup time	30		ns
th(C-D)	RXDi input hold time	90		ns

i=0 to 4

Table 5.45 External Interrupt \overline{INTi} Input (Edge Sensitive)

Symbol	Parameter	Standard		Unit
		Min.	Max.	
tw(INH)	\overline{INTi} input high ("H") pulse width	250		ns
tw(INL)	\overline{INTi} input low ("L") pulse width	250		ns

i=0 to 5

$$VCC1 = VCC2 = 3.3 \text{ V}$$

Timing Requirements

(VCC1 = VCC2 = 3.0 to 3.6 V, VSS = 0 V, Topr = -20 to 85°C unless otherwise specified)

Table 5.46 Microprocessor Mode

Symbol	Parameter	Standard		Unit
		Min.	Max.	
tac1(RD-DB)	Data input access time (RD standard)		(note 1)	ns
tac1(AD-DB)	Data input access time (AD standard, CS standard)		(note 1)	ns
tac2(RD-DB)	Data input access time (RD standard, when accessing a space with the multiplexed bus)		(note 1)	ns
tac2(AD-DB)	Data input access time (AD standard, when accessing a space with the multiplexed bus)		(note 1)	ns
tsu(DB-BCLK)	Data input setup time	30		ns
tsu(RDY-BCLK)	$\overline{\text{RDY}}$ input setup time	40		ns
tsu(HOLD-BCLK)	$\overline{\text{HOLD}}$ input setup time	60		ns
th(RD-DB)	Data input hold time	0		ns
th(BCLK-RDY)	$\overline{\text{RDY}}$ input hold time	0		ns
th(BCLK-HOLD)	$\overline{\text{HOLD}}$ input hold time	0		ns
td(BCLK-HLDA)	$\overline{\text{HLDA}}$ output delay time		25	ns

NOTE:

- Values, which depend on BCLK frequency and external bus cycles, can be obtained from the following equations. Insert wait states or lower the operation frequency, $f(\text{BCLK})$, if the calculated value is negative.

$$tac1(\text{RD-DB}) = \frac{10^9 \times m}{f(\text{BCLK}) \times 2} - 35 \text{ [ns]} \text{ (if external bus cycle is } a\phi + b\phi, m = (b \times 2) + 1)$$

$$tac1(\text{AD-DB}) = \frac{10^9 \times n}{f(\text{BCLK})} - 35 \text{ [ns]} \text{ (if external bus cycle is } a\phi + b\phi, n = a + b)$$

$$tac2(\text{RD-DB}) = \frac{10^9 \times m}{f(\text{BCLK}) \times 2} - 35 \text{ [ns]} \text{ (if external bus cycle is } a\phi + b\phi, m = (b \times 2) - 1)$$

$$tac2(\text{AD-DB}) = \frac{10^9 \times p}{f(\text{BCLK}) \times 2} - 35 \text{ [ns]} \text{ (if external bus cycle is } a\phi + b\phi, p = \{(a + b - 1) \times 2\} + 1)$$

$$VCC1 = VCC2 = 3.3 V$$

Switching Characteristics

(VCC1 = VCC2 = 3.0 to 3.6 V, VSS = 0 V, Topr = -20 to 85°C unless otherwise specified)

Table 5.47 Microprocessor Mode (when accessing external memory space)

Symbol	Parameter	Measurement Condition	Standard		Unit
			Min.	Max.	
td(BCLK-AD)	Address output delay time	See Figure 5.2		18	ns
th(BCLK-AD)	Address output hold time (BCLK standard)		0		ns
th(RD-AD)	Address output hold time (RD standard) ⁽³⁾		0		ns
th(WR-AD)	Address output hold time (WR standard) ⁽³⁾		(note 1)		ns
td(BCLK-CS)	Chip-select signal output delay time			18	ns
th(BCLK-CS)	Chip-select signal output hold time (BCLK standard)		0		ns
th(RD-CS)	Chip-select signal output hold time (RD standard) ⁽³⁾		0		ns
th(WR-CS)	Chip-select signal output hold time (WR standard) ⁽³⁾		(note 1)		ns
td(BCLK-RD)	RD signal output delay time			18	ns
th(BCLK-RD)	RD signal output hold time		-3		ns
td(BCLK-WR)	WR signal output delay time			18	ns
th(BCLK-WR)	WR signal output hold time		0		ns
td(DB-WR)	Data output delay time (WR standard)		(note 2)		ns
th(WR-DB)	Data output hold time (WR standard) ⁽³⁾		(note 1)		ns
tw(WR)	WR output width		(note 2)		ns

NOTES:

- Values, which depend on BCLK frequency, can be obtained from the following equations.

$$th(WR-DB) = \frac{10^9}{f(BCLK) \times 2} - 20 \text{ [ns]}$$

$$th(WR-AD) = \frac{10^9}{f(BCLK) \times 2} - 10 \text{ [ns]}$$

$$th(WR-CS) = \frac{10^9}{f(BCLK) \times 2} - 10 \text{ [ns]}$$

- Values, which depend on BCLK frequency and external bus cycles, can be obtained from the following equations.

$$td(DB-WR) = \frac{10^9 \times m}{f(BCLK)} - 20 \text{ [ns]} \text{ (if external bus cycle is } a\phi + b\phi, m = b)$$

$$tw(WR) = \frac{10^9 \times n}{f(BCLK) \times 2} - 15 \text{ [ns]} \text{ (if external bus cycle is } a\phi + b\phi, n = (b \times 2) - 1)$$

- tc [ns] is added when recovery cycle is inserted.

$$VCC1 = VCC2 = 3.3 V$$

Switching Characteristics

(VCC1 = VCC2 = 3.0 to 3.6 V, VSS = 0 V, Topr = -20 to 85°C unless otherwise specified)

Table 5.48 Microprocessor Mode (when accessing external memory space with multiplexed bus)

Symbol	Parameter	Measurement Condition	Standard		Unit
			Min.	Max.	
td(BCLK-AD)	Address output delay time	See Figure 5.2		18	ns
th(BCLK-AD)	Address output hold time (BCLK standard)		0		ns
th(RD-AD)	Address output hold time (RD standard) ⁽⁵⁾		(note 1)		ns
th(WR-AD)	Address output hold time (WR standard) ⁽⁵⁾		(note 1)		ns
td(BCLK-CS)	Chip-select signal output delay time			18	ns
th(BCLK-CS)	Chip-select signal output hold time (BCLK standard)		0		ns
th(RD-CS)	Chip-select signal output hold time (RD standard) ⁽⁵⁾		(note 1)		ns
th(WR-CS)	Chip-select signal output hold time (WR standard) ⁽⁵⁾		(note 1)		ns
td(BCLK-RD)	RD signal output delay time			18	ns
th(BCLK-RD)	RD signal output hold time		-3		ns
td(BCLK-WR)	WR signal output delay time			18	ns
th(BCLK-WR)	WR signal output hold time		0		ns
td(DB-WR)	Data output delay time (WR standard)		(note 2)		ns
th(WR-DB)	Data output hold time (WR standard) ⁽⁵⁾		(note 1)		ns
td(BCLK-ALE)	ALE signal output delay time (BCLK standard)			18	ns
th(BCLK-ALE)	ALE signal output hold time (BCLK standard)		-2		ns
td(AD-ALE)	ALE signal output delay time (address standard)		(note 3)		ns
th(ALE-AD)	ALE signal output hold time (address standard)		(note 4)		ns
tdz(RD-AD)	Address output float start time			8	ns

NOTES:

- Values, which depend on BCLK frequency, can be obtained from the following equations.

$$th(RD-AD) = \frac{10^9}{f(BCLK) \times 2} - 10 \text{ [ns]}$$

$$th(WR-AD) = \frac{10^9}{f(BCLK) \times 2} - 10 \text{ [ns]}$$

$$th(RD-CS) = \frac{10^9}{f(BCLK) \times 2} - 10 \text{ [ns]}$$

$$th(WR-CS) = \frac{10^9}{f(BCLK) \times 2} - 10 \text{ [ns]}$$

$$th(WR-DB) = \frac{10^9}{f(BCLK) \times 2} - 20 \text{ [ns]}$$

- Values, which depend on BCLK frequency and external bus cycles, can be obtained from the following equation.

$$td(DB-WR) = \frac{10^9 \times m}{f(BCLK) \times 2} - 25 \text{ [ns]} \text{ (if external bus cycle is } a\phi + b\phi, m = (b \times 2) - 1)$$

- Values, which depend on BCLK frequency and external bus cycles, can be obtained from the following equation.

$$td(AD-ALE) = \frac{10^9 \times n}{f(BCLK) \times 2} - 20 \text{ [ns]} \text{ (if external bus cycle is } a\phi + b\phi, n = a)$$

- Values, which depend on BCLK frequency and external bus cycles, can be obtained from the following equation.

$$th(ALE-AD) = \frac{10^9 \times n}{f(BCLK) \times 2} - 10 \text{ [ns]} \text{ (if external bus cycle is } a\phi + b\phi, n = a)$$

- tc [ns] is added when recovery cycle is inserted.

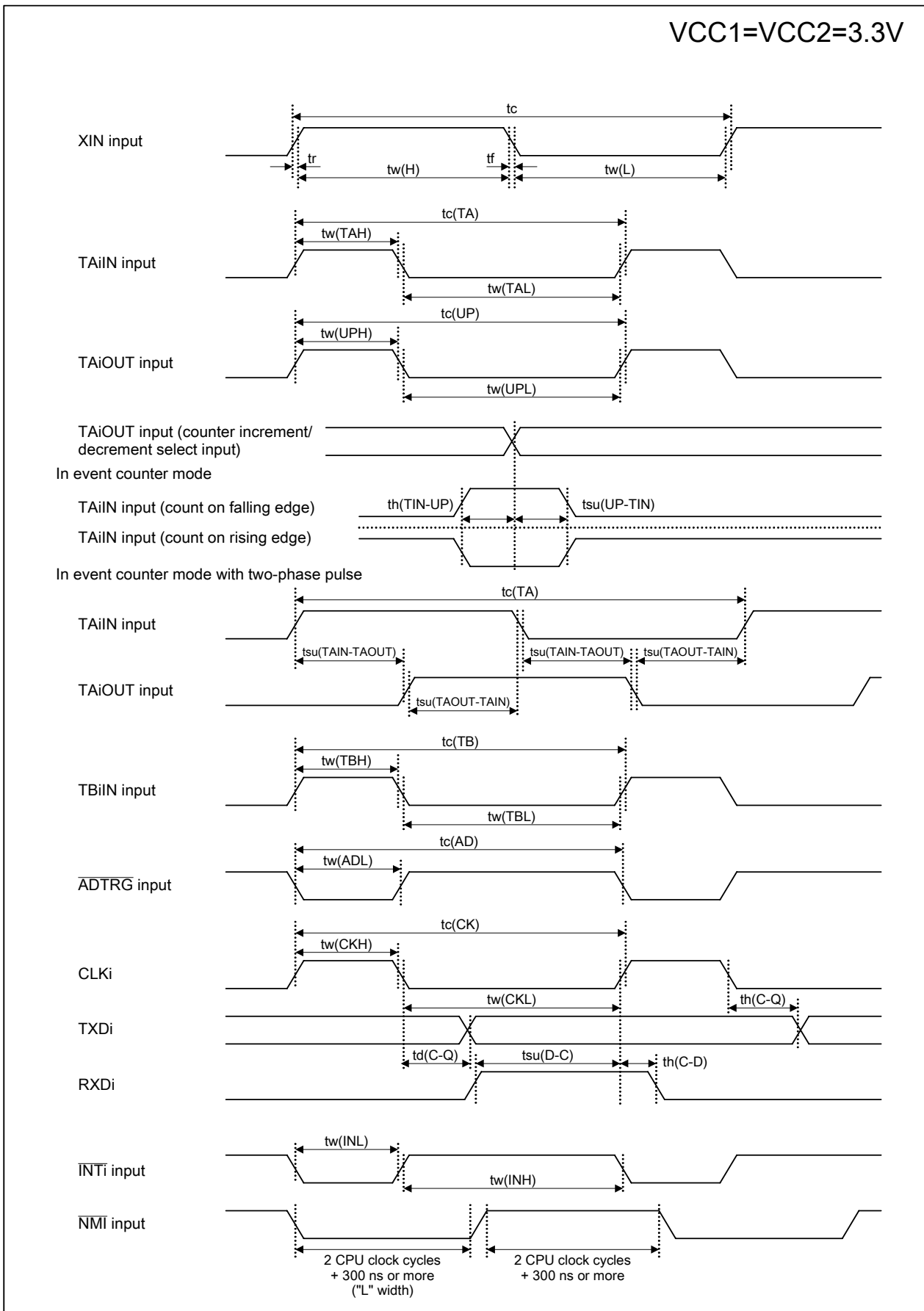

Figure 5.7 VCC1 = VCC2 = 3.3 V Timing Diagram (1)

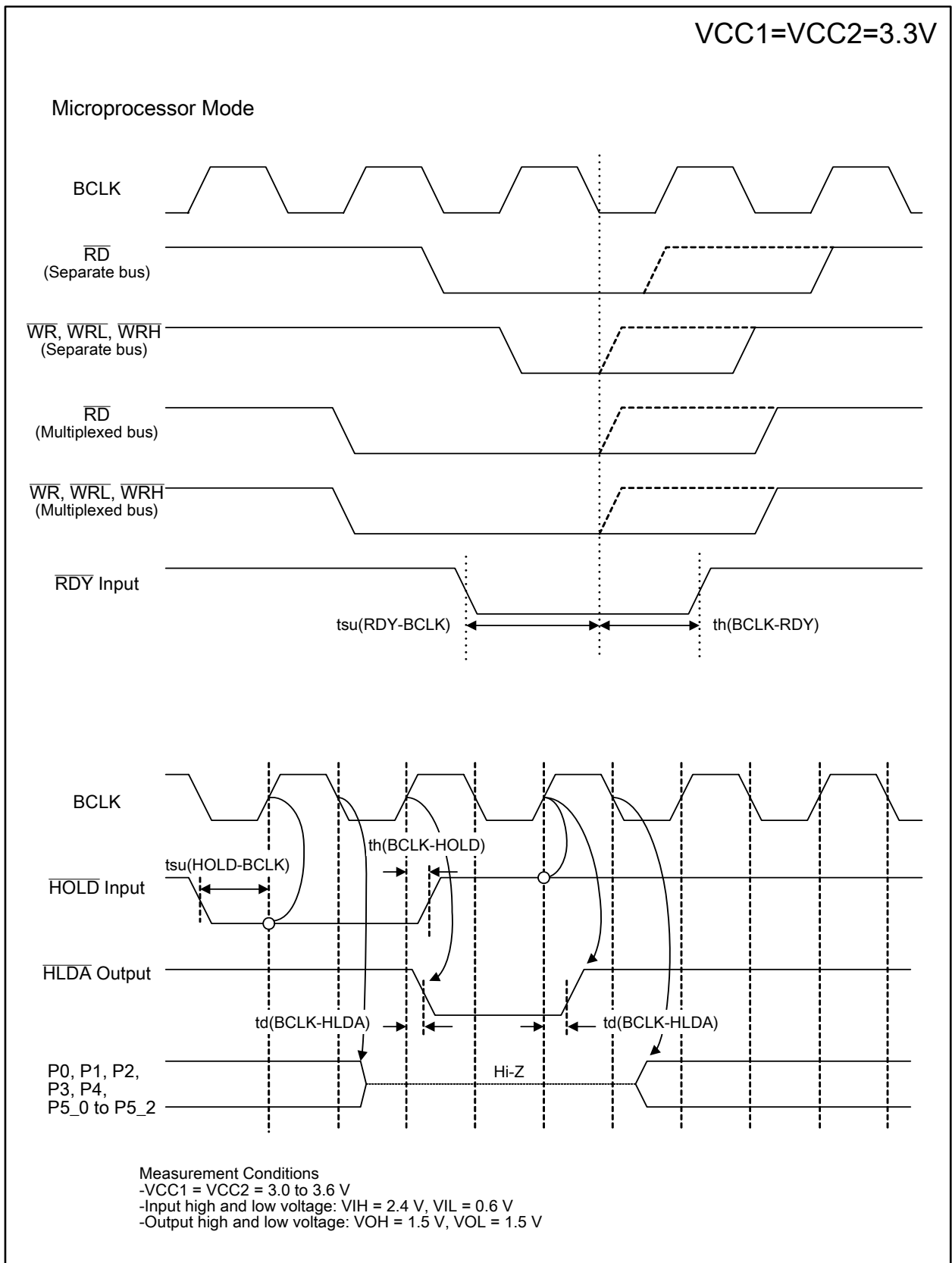

Figure 5.8 VCC1 = VCC2 = 3.3 V Timing Diagram (2)

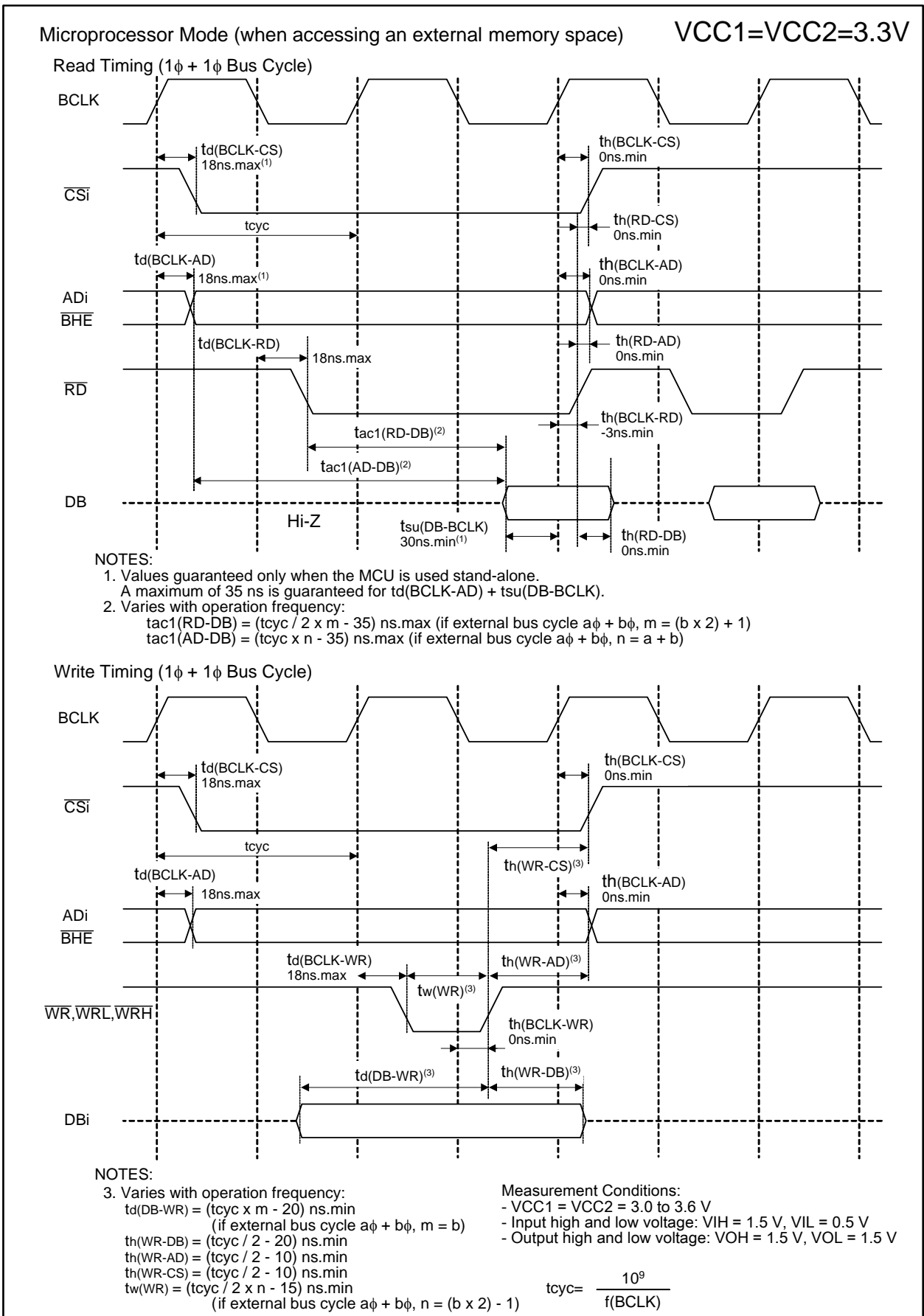

Figure 5.9 VCC1 = VCC2 = 3.3 V Timing Diagram (3)

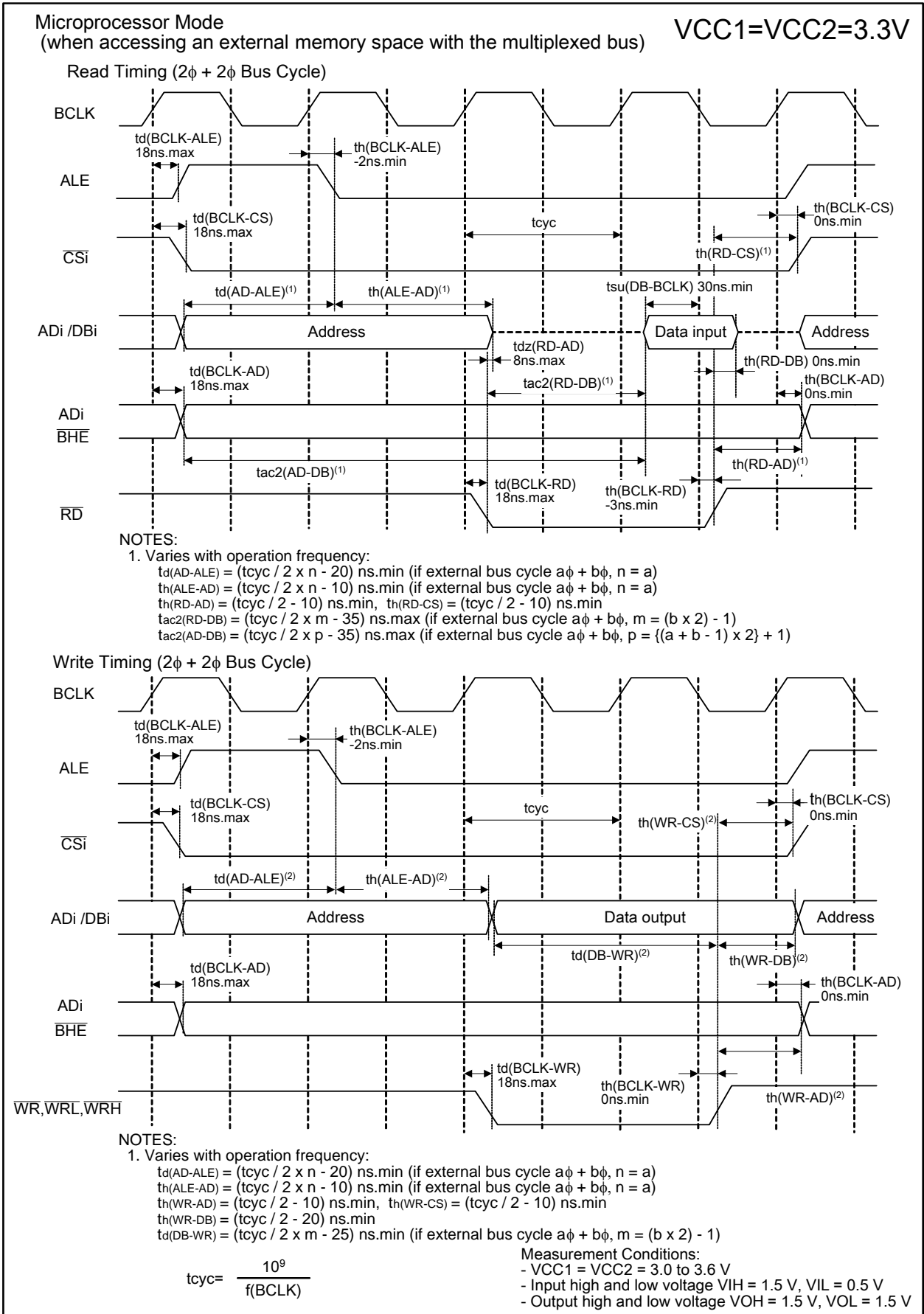
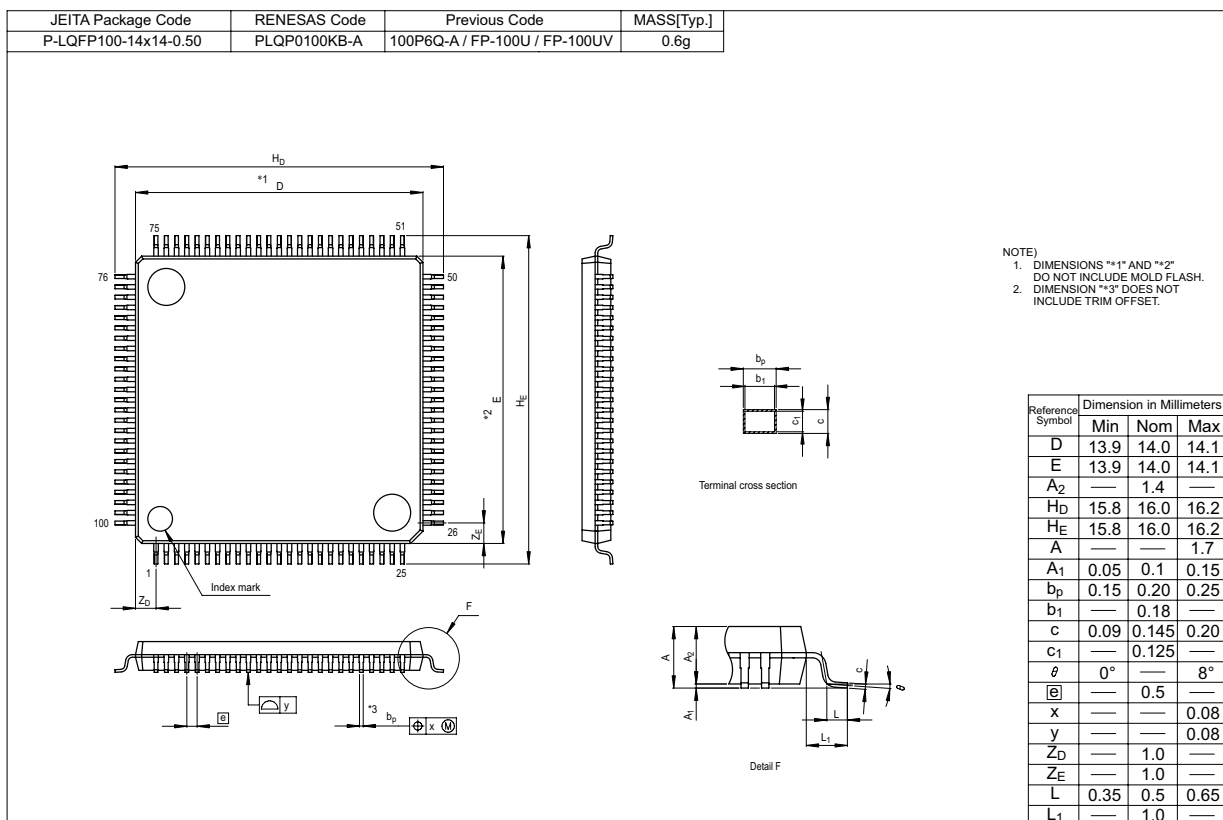
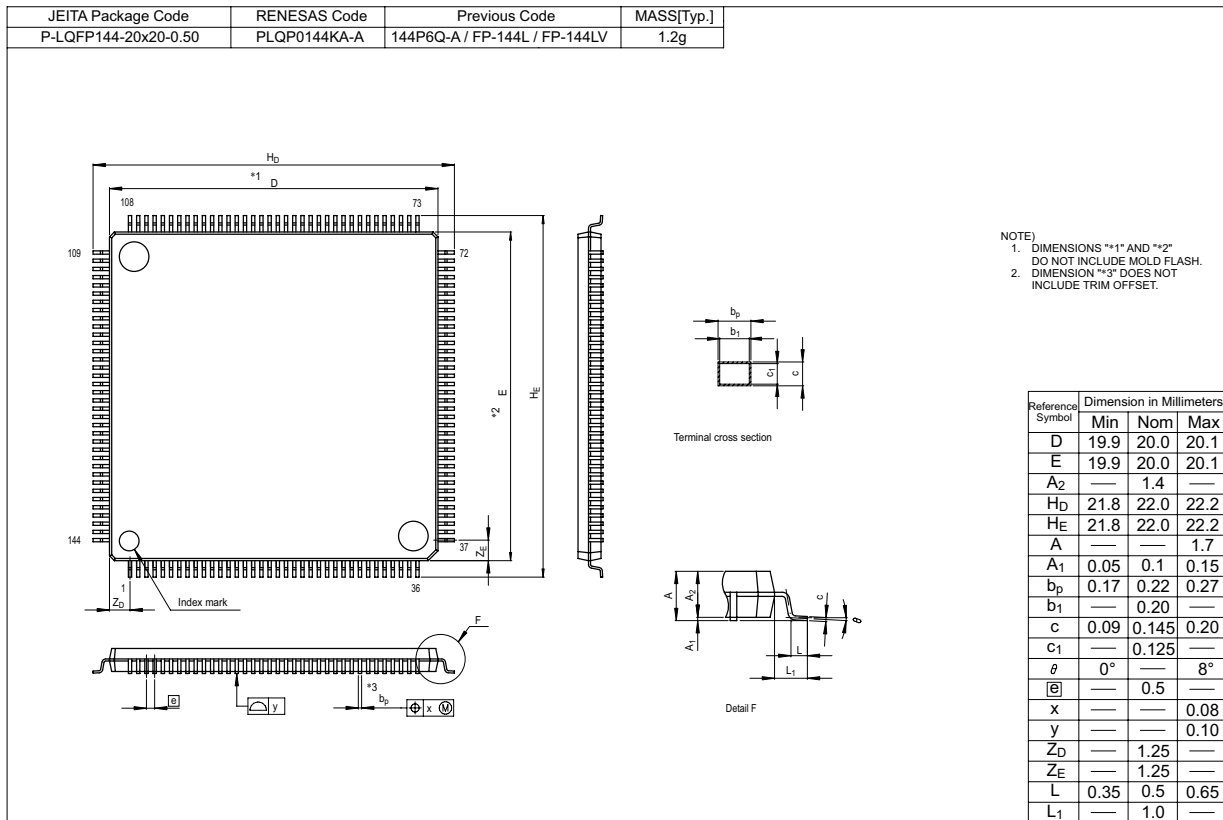

Figure 5.10 VCC1 = VCC2 = 3.3 V Timing Diagram (4)

Appendix 1. Package Dimensions



REVISION HISTORY

M32C/8A Group Datasheet

Rev.	Date	Description	
		Page	Summary
Rev.1.00	Apr 01, 2007	–	First Edition issued
Rev.1.10	Jul 15, 2007	6	- 144-pin package added - Table "Product list" revised

Notes:

1. This document is provided for reference purposes only so that Renesas customers may select the appropriate Renesas products for their use. Renesas neither makes warranties or representations with respect to the accuracy or completeness of the information contained in this document nor grants any license to any intellectual property rights or any other rights of Renesas or any third party with respect to the information in this document.
2. Renesas shall have no liability for damages or infringement of any intellectual property or other rights arising out of the use of any information in this document, including, but not limited to, product data, diagrams, charts, programs, algorithms, and application circuit examples.
3. You should not use the products or the technology described in this document for the purpose of military applications such as the development of weapons of mass destruction or for the purpose of any other military use. When exporting the products or technology described herein, you should follow the applicable export control laws and regulations, and procedures required by such laws and regulations.
4. All information included in this document such as product data, diagrams, charts, programs, algorithms, and application circuit examples, is current as of the date this document is issued. Such information, however, is subject to change without any prior notice. Before purchasing or using any Renesas products listed in this document, please confirm the latest product information with a Renesas sales office. Also, please pay regular and careful attention to additional and different information to be disclosed by Renesas such as that disclosed through our website. (<http://www.renesas.com>)
5. Renesas has used reasonable care in compiling the information included in this document, but Renesas assumes no liability whatsoever for any damages incurred as a result of errors or omissions in the information included in this document.
6. When using or otherwise relying on the information in this document, you should evaluate the information in light of the total system before deciding about the applicability of such information to the intended application. Renesas makes no representations, warranties or guarantees regarding the suitability of its products for any particular application and specifically disclaims any liability arising out of the application and use of the information in this document or Renesas products.
7. With the exception of products specified by Renesas as suitable for automobile applications, Renesas products are not designed, manufactured or tested for applications or otherwise in systems the failure or malfunction of which may cause a direct threat to human life or create a risk of human injury or which require especially high quality and reliability such as safety systems, or equipment or systems for transportation and traffic, healthcare, combustion control, aerospace and aeronautics, nuclear power, or undersea communication transmission. If you are considering the use of our products for such purposes, please contact a Renesas sales office beforehand. Renesas shall have no liability for damages arising out of the uses set forth above.
8. Notwithstanding the preceding paragraph, you should not use Renesas products for the purposes listed below:
 - (1) artificial life support devices or systems
 - (2) surgical implantations
 - (3) healthcare intervention (e.g., excision, administration of medication, etc.)
 - (4) any other purposes that pose a direct threat to human lifeRenesas shall have no liability for damages arising out of the uses set forth in the above and purchasers who elect to use Renesas products in any of the foregoing applications shall indemnify and hold harmless Renesas Technology Corp., its affiliated companies and their officers, directors, and employees against any and all damages arising out of such applications.
9. You should use the products described herein within the range specified by Renesas, especially with respect to the maximum rating, operating supply voltage range, movement power voltage range, heat radiation characteristics, installation and other product characteristics. Renesas shall have no liability for malfunctions or damages arising out of the use of Renesas products beyond such specified ranges.
10. Although Renesas endeavors to improve the quality and reliability of its products, IC products have specific characteristics such as the occurrence of failure at a certain rate and malfunctions under certain use conditions. Please be sure to implement safety measures to guard against the possibility of physical injury, and injury or damage caused by fire in the event of the failure of a Renesas product, such as safety design for hardware and software including but not limited to redundancy, fire control and malfunction prevention, appropriate treatment for aging degradation or any other applicable measures. Among others, since the evaluation of microcomputer software alone is very difficult, please evaluate the safety of the final products or system manufactured by you.
11. In case Renesas products listed in this document are detached from the products to which the Renesas products are attached or affixed, the risk of accident such as swallowing by infants and small children is very high. You should implement safety measures so that Renesas products may not be easily detached from your products. Renesas shall have no liability for damages arising out of such detachment.
12. This document may not be reproduced or duplicated, in any form, in whole or in part, without prior written approval from Renesas.
13. Please contact a Renesas sales office if you have any questions regarding the information contained in this document, Renesas semiconductor products, or if you have any other inquiries.



RENESAS SALES OFFICES

<http://www.renesas.com>

Refer to "<http://www.renesas.com/en/network>" for the latest and detailed information.

Renesas Technology America, Inc.
450 Holger Way, San Jose, CA 95134-1368, U.S.A
Tel: <1> (408) 382-7500, Fax: <1> (408) 382-7501

Renesas Technology Europe Limited
Dukes Meadow, Millboard Road, Bourne End, Buckinghamshire, SL8 5FH, U.K.
Tel: <44> (1628) 585-100, Fax: <44> (1628) 585-900

Renesas Technology (Shanghai) Co., Ltd.
Unit 204, 205, AZIACenter, No.1233 Lujiazui Ring Rd, Pudong District, Shanghai, China 200120
Tel: <86> (21) 5877-1818, Fax: <86> (21) 6887-7898

Renesas Technology Hong Kong Ltd.
7th Floor, North Tower, World Finance Centre, Harbour City, 1 Canton Road, Tsimshatsui, Kowloon, Hong Kong
Tel: <852> 2265-6688, Fax: <852> 2730-6071

Renesas Technology Taiwan Co., Ltd.
10th Floor, No.99, Fushing North Road, Taipei, Taiwan
Tel: <886> (2) 2715-2888, Fax: <886> (2) 2713-2999

Renesas Technology Singapore Pte. Ltd.
1 Harbour Front Avenue, #06-10, Keppel Bay Tower, Singapore 098632
Tel: <65> 6213-0200, Fax: <65> 6278-8001

Renesas Technology Korea Co., Ltd.
Kukje Center Bldg. 18th Fl., 191, 2-ka, Hangang-ro, Yongsan-ku, Seoul 140-702, Korea
Tel: <82> (2) 796-3115, Fax: <82> (2) 796-2145

Renesas Technology Malaysia Sdn. Bhd
Unit 906, Block B, Menara Amcorp, Amcorp Trade Centre, No.18, Jalan Persiaran Barat, 46050 Petaling Jaya, Selangor Darul Ehsan, Malaysia
Tel: <603> 7955-9390, Fax: <603> 7955-9510