

CF Chip Type, Standard series



NEW

- Ultra Low ESR, High ripple current.
- Load life of 2000 hours at 105°C.
- SMD type : Lead free reflow soldering condition at 260°C peak correspondence.
- Adapted to the RoHS directive (2002/95/EC).



Specifications

Item	Performance Characteristics		
Category Temperature Range	-55 ~ +105°C		
Rated Voltage Range	2.5 ~ 25V		
Rated Capacitance Range	6.8 ~ 1500μF		
Capacitance Tolerance	±20% at 120Hz, 20°C		
tan δ	Not more than value of Standard ratings at 120Hz, 20°C		
ESR (※ 1)	Not more than value of Standard ratings at 100kHz, 20°C		
Leakage Current (※ 2)	Not more than value of Standard ratings. After 2 minute's application of rated voltage. 20°C		
Characteristics of Temperature Impedance Ratio	$Z+105^{\circ}\text{C} / Z+20^{\circ}\text{C} \leq 1.25$ (100kHz) $Z-55^{\circ}\text{C} / Z+20^{\circ}\text{C} \leq 1.25$		
Endurance	After 2000 hours' application of rated voltage at 105°C, capacitors meet the specified value for life characteristics listed at right.	Capacitance change	Within ±20% of initial value (※ 3)
		tan δ	150% or less of the initial specified value
		ESR (※ 1)	150% or less of the initial specified value
		Leakage current (※ 2)	Initial specified value or less
Damp Heat	After 1000 hours' application of rated voltage at 60°C 90%RH, capacitors meet the specified value for life characteristics listed at right.	Capacitance change	Within ±20% of initial value (※ 3)
		tan δ	150% or less of the initial specified value
		ESR (※ 1)	150% or less of the initial specified value
		Leakage current (※ 2)	Initial specified value or less
Resistance to Soldering Heat	To comply with recommended conditions for reflow soldering. Pre-heating shall be done at 150 ~ 200°C and for 60 ~ 180 sec. In the case of peak temp, less than 250°C, reflow soldering shall be within two times. In the case of peak temp, less than 260°C, reflow soldering shall be once. Measurement for solder temperature profile shall be made at the capacitor top and the terminal.	Capacitance change	Within ±10% of initial value (※ 3)
		tan δ	130% or less of the initial specified value
		ESR (※ 1)	130% or less of the initial specified value
		Leakage current (※ 2)	Initial specified value or less
Marking	Navy blue print on the case top		

※ 1 ESR measurements should be made at a point on the terminal nearest where the terminals protrude through the plastic platform.

※ 2 Conditioning : If there is doubt about the measured result, measurement should be made again after the rated voltage is applied for 120 minutes at the temperature of 105°C.

※ 3 Initial value : The value before test of examination of resistance to soldering.

Dimensions

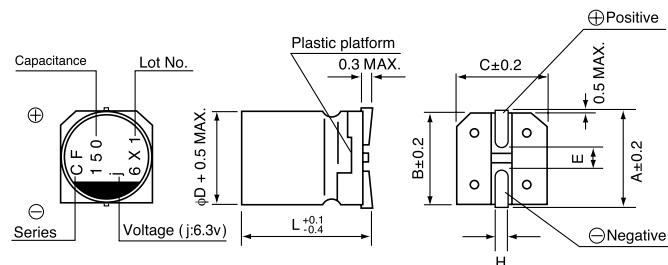

	(mm)			
Size	φ6.3 × 6L	φ8 × 7L	φ10 × 8L	φ10 × 10L
φD	6.3	8.0	10.0	10.0
L	5.9	6.9	7.9	9.9
A	7.3	9.0	11.0	11.0
B	6.6	8.3	10.3	10.3
C	6.6	8.3	10.3	10.3
E	2.1	3.2	4.6	4.6
H	0.5 ~ 0.8	0.8 ~ 1.1	0.8 ~ 1.1	0.8 ~ 1.1

Type numbering system (Example : 6.3V 150μF)

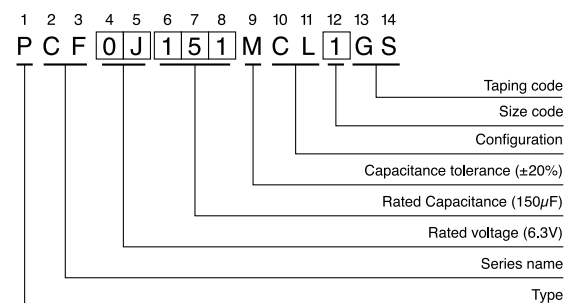

Voltage

V	2.5	4	6.3	10	16	20	25
Code	e	g	j	A	C	D	E

● Dimension table in next page.

■ Standard ratings

Rated Voltage (V) (code)	Rated Capacitance (μF)	Case Size φD×L (mm)	tan δ	Leakage Current (μA)	ESR (mΩ) (at 100kHz 20°C)	Rated ripple (mArms)	Part Number
2.5 (0E)	100	6.3×6	0.12	100	22	2600	PCF0E101MCL1GS
	220	6.3×6	0.12	110	20	2800	PCF0E221MCL1GS
	470	8×7	0.12	235	20	3300	PCF0E471MCL1GS
	820	10×8	0.12	410	17	4400	PCF0E821MCL1GS
	1500	10×10	0.12	750	13	4700	PCF0E152MCL1GS
4 (0G)	100	6.3×6	0.12	80	22	2600	PCF0G101MCL1GS
	150	6.3×6	0.12	120	22	2800	PCF0G151MCL1GS
	220	8×7	0.12	176	21	3200	PCF0G221MCL1GS
	330	8×7	0.12	264	21	3400	PCF0G331MCL1GS
	470	10×8	0.12	376	17	4200	PCF0G471MCL1GS
	680	10×8	0.12	544	17	4400	PCF0G681MCL1GS
	820	10×10	0.12	656	13	4800	PCF0G821MCL1GS
6.3 (0J)	82	6.3×6	0.12	103	23	2600	PCF0J820MCL1GS
	100	6.3×6	0.12	126	23	2800	PCF0J101MCL1GS
	120	6.3×6	0.12	151	23	3000	PCF0J121MCL1GS
	150	8×7	0.12	189	22	3200	PCF0J151MCL1GS
	220	8×7	0.12	277	22	3400	PCF0J221MCL1GS
	330	10×8	0.12	416	18	4200	PCF0J331MCL1GS
	470	▲ 10×8	0.12	592	18	4300	PCF0J471MCL6GS
	470	10×10	0.12	592	16	4600	PCF0J471MCL1GS
10 (1A)	680	10×10	0.12	856	14	5000	PCF0J681MCL1GS
	47	6.3×6	0.12	94	26	2600	PCF1A470MCL1GS
	56	6.3×6	0.12	112	25	2500	PCF1A560MCL1GS
	120	8×7	0.12	240	23	3000	PCF1A121MCL1GS
	150	▲ 8×7	0.12	300	23	3200	PCF1A151MCL6GS
	150	10×8	0.12	300	21	3300	PCF1A151MCL1GS
	270	10×8	0.12	540	20	3600	PCF1A271MCL1GS
	330	10×8	0.12	660	20	3700	PCF1A331MCL1GS
	470	10×10	0.12	940	16	4600	PCF1A471MCL1GS
	560	10×10	0.12	1120	15	4800	PCF1A561MCL1GS
16 (1C)	33	6.3×6	0.12	106	31	2400	PCF1C330MCL1GS
	39	6.3×6	0.12	124	31	2400	PCF1C390MCL1GS
	56	8×7	0.12	179	30	2900	PCF1C560MCL1GS
	82	8×7	0.12	262	28	3200	PCF1C820MCL1GS
	150	10×8	0.12	480	25	3500	PCF1C151MCL1GS
	180	10×8	0.12	576	25	3600	PCF1C181MCL1GS
	220	10×10	0.12	704	20	3900	PCF1C221MCL1GS
20 (1D)	22	6.3×6	0.12	88	50	1700	PCF1D220MCL1GS
	39	8×7	0.12	156	45	2000	PCF1D390MCL1GS
	68	10×8	0.12	272	40	2600	PCF1D680MCL1GS
	82	10×8	0.12	328	40	2600	PCF1D820MCL1GS
	120	10×10	0.12	480	35	2800	PCF1D121MCL1GS
25 (1E)	6.8	6.3×6	0.12	85	80	1200	PCF1E6R8MCL1GS
	10	8×7	0.12	125	60	1600	PCF1E100MCL1GS
	22	10×8	0.12	275	50	2200	PCF1E220MCL1GS
	47	10×10	0.12	587	45	2400	PCF1E470MCL1GS

No marked, [1] will be put at 12th digit of type numbering system.

Rated Ripple (mArms) at 105°C 100kHz

▲ : In this case, [6] will be put at 12th digit of type numbering system.

- Taping specifications are given in page 24.
- Recommended land size, soldering by reflow are given in page 25, 26.
- Please refer to page 3 for the minimum order quantity.