

DDR3 SDRAM Unbuffered SODIMMs Based on 1Gb B version

**HMT164S6BFR6C
HMT112S6BFR6C
HMT125S6BFR8C**

**** Contents are subject to change without prior notice.**

Revision History

Revision No.	History	Draft Date	Remark
0.1	Initial Release	Oct. 2008	
0.2	Modified Speed grade. Corrected typo on package ball feature.	Dec. 2008	
0.3	Added IDD Specification	Feb. 2009	
0.4	Updated IDD Specification	Apr. 2009	
0.5	Corrected typo	Sep. 2009	

Table of Contents

1. Description

- 1.1 Device Features and Ordering Information
 - 1.1.1 Features
 - 1.1.2 Ordering Information
- 1.2 Speed Grade & Key Parameters
- 1.3 Address Table

2. Pin Architecture

- 2.1 Pin Definition
- 2.2 Input/Output Functional Description
- 2.3 Pin Assignment

3. Functional Block Diagram

- 3.1 512MB, 64Mx64 Module(1Rank of x16)
- 3.2 1GB, 128Mx64 Module(2Rank of x16)
- 3.3 2GB, 256Mx64 Module(2Rank of x8)

4. Absolute Maximum Ratings

- 4.1 Absolute Maximum DC Ratings
- 4.2 Operating Temperature Range

5. AC & DC Operating Conditions

- 5.1 Recommended DC Operating Conditions
- 5.2 DC & AC Logic Input Levels
 - 5.2.1 For Single-ended Signals
 - 5.2.2 For Differential Signals
 - 5.2.3 Differential Input Cross Point
- 5.3 Slew Rate Definition
 - 5.3.1 For Ended Input Signals
 - 5.3.2 For Differential Input Signals
- 5.4 DC & AC Output Buffer Levels
 - 5.4.1 Single Ended DC & AC Output Levels
 - 5.4.2 Differential DC & AC Output Levels
 - 5.4.3 Single Ended Output Slew Rate
 - 5.4.4 Differential Ended Output Slew Rate
- 5.5 Overshoot/Undershoot Specification
 - 5.5.1 Address and Control Overshoot and Undershoot Specifications
 - 5.5.2 Clock, Data, Strobe and Mask Overshoot and Undershoot Specifications
- 5.6 Input/Output Capacitance & AC Parametrics
- 5.7 IDD Specifications & Measurement Conditions

6. Electrical Characteristics and AC Timing

- 6.1 Refresh Parameters by Device Density
- 6.2 DDR3 Standard speed bins and AC para

7. DIMM Outline Diagram

- 7.1 512MB, 64Mx64 Module(1Rank of x16)
- 7.2 1GB, 128Mx64 Module(2Rank of x16)
- 7.3 2GB, 256Mx64 Module(2Rank of x8)

1. Description

This Hynix unbuffered Small Outline Dual In-Line Memory Module (SODIMM) series consists of 1Gb B version. DDR3 SDRAMs in Fine Ball Grid Array (FBGA) packages on a 204 pin glass-epoxy substrate. This DDR3 Unbuffered SODIMM series based on 1Gb B version provide a high performance 8 byte interface in 67.60mm width form factor of industry standard. It is suitable for easy interchange and addition.

1.1 Device Features & Ordering Information

1.1.1 Features

- VDD=VDDQ=1.5V
- VDDSPD=3.0V to 3.6V
- Fully differential clock inputs (CK, /CK) operation
- Differential Data Strobe (DQS, /DQS)
- On chip DLL align DQ, DQS and /DQS transition with CK transition
- DM masks write data-in at the both rising and falling edges of the data strobe
- All addresses and control inputs except data, data strobes and data masks latched on the rising edges of the clock
- Programmable CAS latency 5, 6, 7, 8, 9, 10, and (11) supported
- Programmable additive latency 0, CL-1 and CL-2 supported
- Programmable CAS Write latency (CWL) = 5, 6, 7, 8
- Programmable burst length 4/8 with both nibble sequential and interleave mode
- BL switch on the fly
- 8 banks
- 8K refresh cycles /64ms
- DDR3 SDRAM Package: JEDEC standard 78ball FBGA(x4/x8), 96ball FBGA(x16) with support balls
- Driver strength selected by EMRS
- Dynamic On Die Termination supported
- Asynchronous RESET pin supported
- ZQ calibration supported
- TDQS (Termination Data Strobe) supported (x8 only)
- Write Levelization supported
- Auto Self Refresh supported
- 8 bit pre-fetch

* This product is in compliance with the RoHS directive.

1.1.2 Ordering Information

Part Name	Density	Organization	# of DRAMs	# of ranks	Materials
HMT164S6BFR6C-G7/H9	512MB	64Mx64	4	1	Halogen free
HMT112S6BFR6C-G7/H9	1GB	128Mx64	8	2	Halogen free
HMT125S6BFR8C-G7/H9	2GB	256Mx64	16	2	Halogen free

Two types, with integrated thermal sensor and with no thermal sensor, exist in each configuration.

1.2 Speed Grade & Key Parameters

MT/S	DDR3-1066	DDR3-1333	Unit
Grade	-G7	-H9	
tCK (min)	1.875	1.5	ns
CAS Latency	7	9	tCK
tRCD (min)	13.125	13.5	ns
tRP (min)	13.125	13.5	ns
tRAS (min)	37.5	36	ns
tRC (min)	50.625	49.5	ns
CL-tRCD-tRP	7-7-7	9-9-9	tCK

1.3 Address Table

	512MB	1GB	2GB
Organization	64M x 64	128M x 64	256M x 64
Refresh Method	8K/64ms	8K/64ms	8K/64ms
Row Address	A0-A12	A0-A12	A0-A13
Column Address	A0-A9	A0-A9	A0-A9
Bank Address	BA0-BA2	BA0-BA2	BA0-BA2
Page Size	2KB	2KB	1KB
# of Rank	1	2	2
# of Device	4	8	16

2. Pin Architecture

2.1 Pin Definition

Pin Name	Description		Pin Name	Description	
CK[1:0]	Clock Inputs, positive line	2	DQ[63:0]	Data Input/Output	64
$\overline{\text{CK}}$ [1:0]	Clock Inputs, negative line	2	DM[7:0]	Data Masks	8
CKE[1:0]	Clock Enables	2	DQS[7:0]	Data strobes	8
$\overline{\text{RAS}}$	Row Address Strobe	1	$\overline{\text{DQS}}$ [7:0]	Data strobes complement	8
$\overline{\text{CAS}}$	Column Address Strobe	1	$\overline{\text{RESET}}$	Reset pin	1
$\overline{\text{WE}}$	Write Enable	1	TEST	Logic Analyzer specific test pin (No connect on SODIMM)	1
$\overline{\text{S}}$ [1:0]	Chip Selects	2	$\overline{\text{EVENT}}$	Temperature event pin	1
A[9:0], A11, A[15:13]	Address Inputs	14	V _{DD}	Core and I/O power	18
A10/AP	Address Input/Autoprecharge	1	V _{SS}	Ground	52
A12/ $\overline{\text{BC}}$	Address Input/Burst Stop	1	V _{REFDQ}	Input/Output Reference	2
BA[2:0]	SDRAM Bank Address	3	V _{REFCA}		
$\overline{\text{ODT}}$ [1:0]	On-die termination control	2	V _{DDSPD}	SPD and Temp sensor power	1
SCL	Serial Presence Detect (SPD) Clock input	1	V _{tt}	Termination voltage	2
SDA	SPD Data Input/Output	1	NC	Reserved for future use	2
$\overline{\text{SA}}$ [1:0]	SPD address	2		Total	204

2.2 Input/Output Functional Description

Symbol	Type	Polarity	Function
CK0/ $\overline{\text{CK0}}$ CK1/ $\overline{\text{CK1}}$	Input	Cross point	The system clock inputs. All address and command lines are sampled on the cross point of the rising edge of CK and falling edge of $\overline{\text{CK}}$. A Delay Locked Loop (DLL) circuit is driven from the clock inputs and output timing for read operations is synchronized to the input clock.
CKE[1:0]	Input	Active High	Activates the DDR3 SDRAM CK signal when high and deactivates the CK signal when low. By deactivating the clocks, CKE low initiates the Power Down mode or the Self Refresh mode.
$\overline{\text{S}}[1:0]$	Input	Active Low	Enables the associated DDR3 SDRAM command decoder when low and disables the command decoder when high. When the command decoder is disabled, new commands are ignored but previous operations continue. Rank 0 is selected by $\overline{\text{S}}0$; Rank 1 is selected by $\overline{\text{S}}1$.
$\overline{\text{RAS}}$, $\overline{\text{CAS}}$, $\overline{\text{WE}}$	Input	Active Low	When sampled at the cross point of the rising edge of CK and falling edge of $\overline{\text{CK}}$, signals $\overline{\text{CAS}}$, $\overline{\text{RAS}}$, and $\overline{\text{WE}}$ define the operation to be executed by the SDRAM.
BA[2:0]	Input	-	Selects which DDR3 SDRAM internal bank of eight is activated.
ODT[1:0]	Input	Active High	Asserts on-die termination for DQ, DM, DQS, and $\overline{\text{DQS}}$ signals if enabled via the DDR3 SDRAM mode register.
A[9:0], A10/ $\overline{\text{AP}}$, A11, A12/ $\overline{\text{BC}}$, A[15:13]	Input	-	During a Bank Activate command cycle, defines the row address when sampled at the cross point of the rising edge of CK and falling edge of $\overline{\text{CK}}$. During a Read or Write command cycle, defines the column address when sampled at the cross point of the rising edge of CK and falling edge of $\overline{\text{CK}}$. In addition to the column address, AP is used to invoke autoprecharge operation at the end of the burst read or write cycle. If AP is high, autoprecharge is selected and BA0-BA7 defines the bank to be precharged. If AP is low, autoprecharge is disabled. During a Precharge command cycle, AP is used in conjunction with BA0-BA7 to control which bank(s) to precharge. If AP is high, all banks will be precharged regardless of the state of BA0-BA7 inputs. If AP is low, then BA0-BA7 are used to define which bank to precharge. A12($\overline{\text{BC}}$) is sampled during READ and WRITE commands to determine if burst chop (on-the-fly) will be performed (HIGH, no burst chop; LOW, burst chopped)
DQ[63:0]	In/Out	-	Data Input/Output pins.
DM[7:0]	Input	Active High	The data write masks, associated with one data byte. In Write mode, DM operates as a byte mask by allowing input data to be written if it is low but blocks the write operation if it is high. In Read mode, DM lines have no effect.
DQS[7:0], $\overline{\text{DQS}}$ [7:0]	In/Out	Cross Point	The data strobes, associated with one data byte, sourced with data transfers. In Write mode, the data strobe is sourced by the controller and is centered in the data window. In Read mode, the data strobe is sourced by the DDR3 SDRAMs and is sent at the leading edge of the data window. $\overline{\text{DQS}}$ signals are complements, and timing is relative to the crosspoint of respective DQS and $\overline{\text{DQS}}$.

Symbol	Type	Polarity	Function
$V_{DD}, V_{DDSPD}, V_{SS}$	Supply		Power supplies for core, I/O, Serial Presence Detect, Temp sensor, and ground for the module.
V_{REFDQ}, V_{REFCA}	Supply		Reference voltage for SSTL15 inputs.
SDA	In/Out		This is a bidirectional pin used to transfer data into or out of the SPD EEPROM and Temp sensor. A resistor must be connected from the SDA bus line to V_{DDSPD} on the system planar to act as a pull up.
SCL	Input		This signal is used to clock data into and out of the SPD EEPROM and Temp sensor.
SA[1:0]	Input		Address pins used to select the Serial Presence Detect and Temp sensor base address.
TEST	In/Out		The TEST pin is reserved for bus analysis tools and is not connected on normal memory modules (SO-DIMMs).
$\overline{\text{EVENT}}$	Wire OR Out	Active Low	The EVENT pin is reserved for use to flag critical module temperature. A resistor may be connected from EVENT bus line to V_{DDSPD} on the system planar to act as a pullup.
$\overline{\text{RESET}}$	In	Active Low	This signal resets the DDR3 SDRAM

2.3 Pin Assignment

Pin #	Front Side	Pin #	Back Side	Pin #	Front Side	Pin #	Back Side	Pin #	Front Side	Pin #	Back Side	Pin #	Front Side	Pin #	Back Side
1	V _{REFDQ}	2	V _{SS}	53	DQ19	54	V _{SS}	105	V _{DD}	106	V _{DD}	157	DQ42	158	DQ46
3	V _{SS}	4	DQ4	55	V _{SS}	56	DQ28	107	A10/AP	108	BA1	159	DQ43	160	DQ47
5	DQ0	6	DQ5	57	DQ24	58	DQ29	109	BA0	110	$\overline{\text{RAS}}$	161	V _{SS}	162	V _{SS}
7	DQ1	8	V _{SS}	59	DQ25	60	V _{SS}	111	V _{DD}	112	V _{DD}	163	DQ48	164	DQ52
9	V _{SS}	10	$\overline{\text{DQS0}}$	61	V _{SS}	62	$\overline{\text{DQS3}}$	113	$\overline{\text{WE}}$	114	$\overline{\text{S0}}$	165	DQ49	166	DQ53
11	DM0	12	DQS0	63	DM3	64	DQS3	115	$\overline{\text{CAS}}$	116	ODT0	167	V _{SS}	168	V _{SS}
13	V _{SS}	14	V _{SS}	65	V _{SS}	66	V _{SS}	117	V _{DD}	118	V _{DD}	169	$\overline{\text{DQS6}}$	170	DM6
15	DQ2	16	DQ6	67	DQ26	68	DQ30	119	A13 ²	120	ODT1	171	DQS6	172	V _{SS}
17	DQ3	18	DQ7	69	DQ27	70	DQ31	121	$\overline{\text{S1}}$	122	NC	173	V _{SS}	174	DQ54
19	V _{SS}	20	V _{SS}	71	V _{SS}	72	V _{SS}	123	V _{DD}	124	V _{DD}	175	DQ50	176	DQ55
21	DQ8	22	DQ12	73	CKE0	74	CKE1	125	TEST	126	V _{REFCA}	177	DQ51	178	V _{SS}
23	DQ9	24	DQ13	75	V _{DD}	76	V _{DD}	127	V _{SS}	128	V _{SS}	179	V _{SS}	180	DQ60
25	V _{SS}	26	V _{SS}	77	NC	78	A15 ²	129	DQ32	130	DQ36	181	DQ56	182	DQ61
27	$\overline{\text{DQS1}}$	28	DM1	79	BA2	80	A14 ²	131	DQ33	132	DQ37	183	DQ57	184	V _{SS}
29	DQS1	30	$\overline{\text{RESET}}$	81	V _{DD}	82	V _{DD}	133	V _{SS}	134	V _{SS}	185	V _{SS}	186	$\overline{\text{DQS7}}$
31	V _{SS}	32	V _{SS}	83	A12/ $\overline{\text{BC}}$	84	A11	135	$\overline{\text{DQS4}}$	136	DM4	187	DM7	188	DQS7
33	DQ10	34	DQ14	85	A9	86	A7	137	DQS4	138	V _{SS}	189	V _{SS}	190	V _{SS}
35	DQ11	36	DQ15	87	V _{DD}	88	V _{DD}	139	V _{SS}	140	DQ38	191	DQ58	192	DQ62
37	V _{SS}	38	V _{SS}	89	A8	90	A6	141	DQ34	142	DQ39	193	DQ59	194	DQ63
39	DQ16	40	DQ20	91	A5	92	A4	143	DQ35	144	V _{SS}	195	V _{SS}	196	V _{SS}
41	DQ17	42	DQ21	93	V _{DD}	94	V _{DD}	145	V _{SS}	146	DQ44	197	SA0	198	$\overline{\text{EVENT}}$
43	V _{SS}	44	V _{SS}	95	A3	96	A2	147	DQ40	148	DQ45	199	VDD _{SPD}	200	SDA
45	$\overline{\text{DQS2}}$	46	DM2	97	A1	98	A0	149	DQ41	150	V _{SS}	201	SA1	202	SCL
47	DQS2	48	V _{SS}	99	V _{DD}	100	V _{DD}	151	V _{SS}	152	$\overline{\text{DQS5}}$	203	V _{TT}	204	V _{TT}
49	V _{SS}	50	DQ22	101	CK0	102	CK1	153	DM5	154	DQS5				
51	DQ18	52	DQ23	103	$\overline{\text{CK0}}$	104	$\overline{\text{CK1}}$	155	V _{SS}	156	V _{SS}				

NC = No Connect; RFU = Reserved Future Use

1. TEST (pin 125) is reserved for bus analysis probes and is NC on normal memory modules.
2. This address might be connected to NC balls of the DRAMs (depending on density); either way they will be connected to the termination resistor.

3. Functional Block Diagram

3.1 512MB, 64Mx64 Module(1Rank of x16)

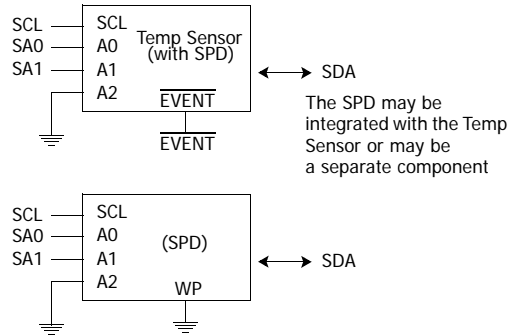
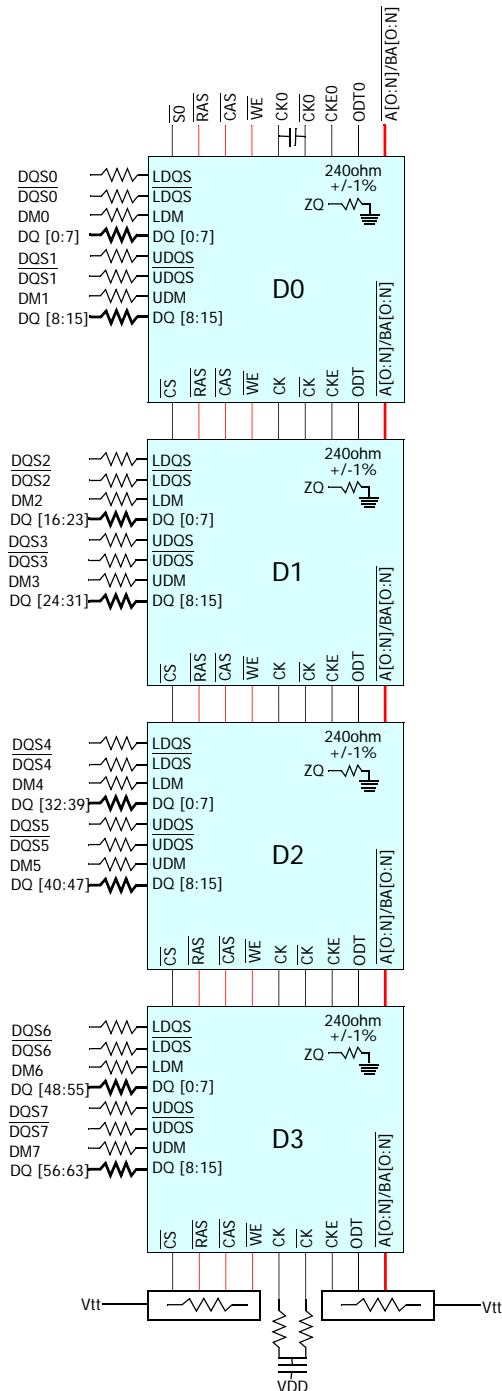

The SPD may be integrated with the Temp Sensor or may be a separate component

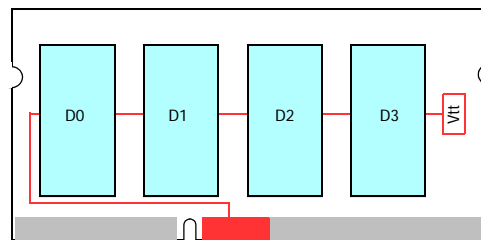
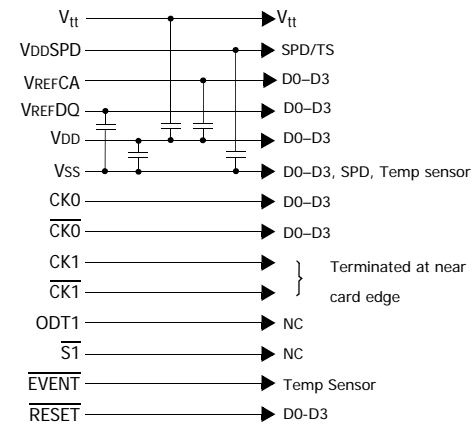

— Address and Control Lines

NOTES

1. DQ wiring may differ from that shown however, DQ, DM, DQS, and DQS relationships are maintained as shown

Rank 0

3.2 1GB, 128Mx64 Module(2Rank of x16)

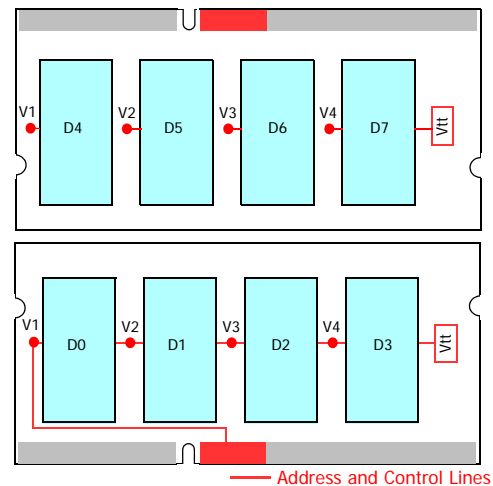
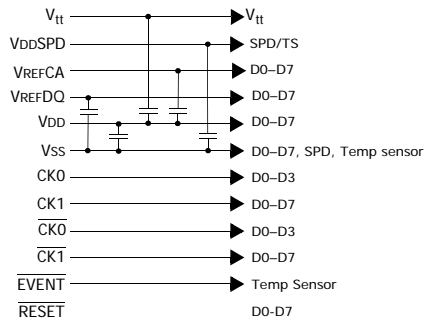
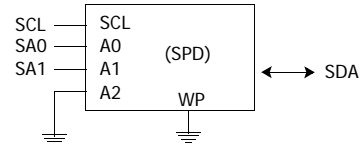
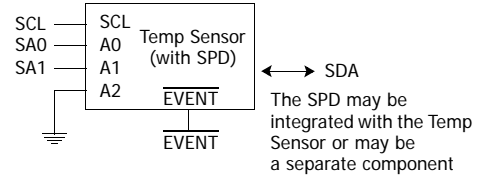
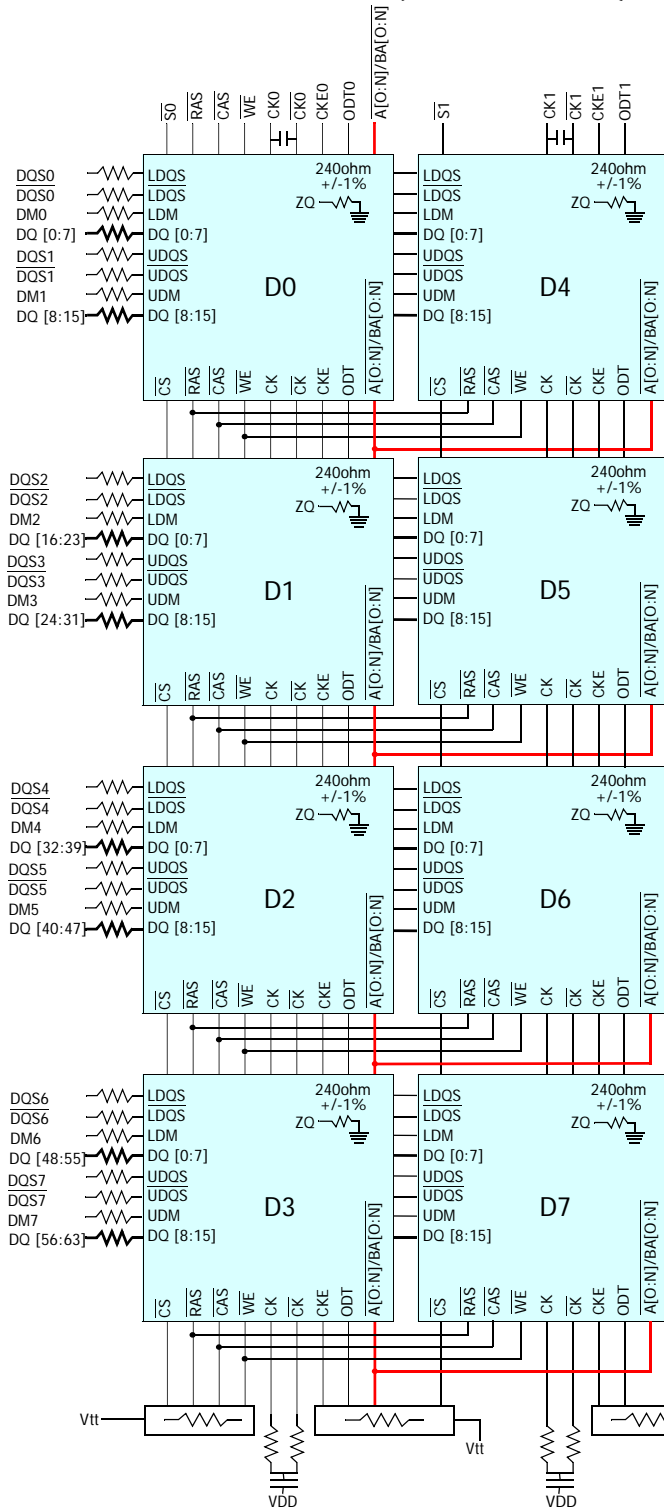

NOTES

- DQ wiring may differ from that shown however, DQ, DM, DQS, and DQS relationships are maintained as shown



3.3 2GB, 256Mx64 Module(2Rank of x8)

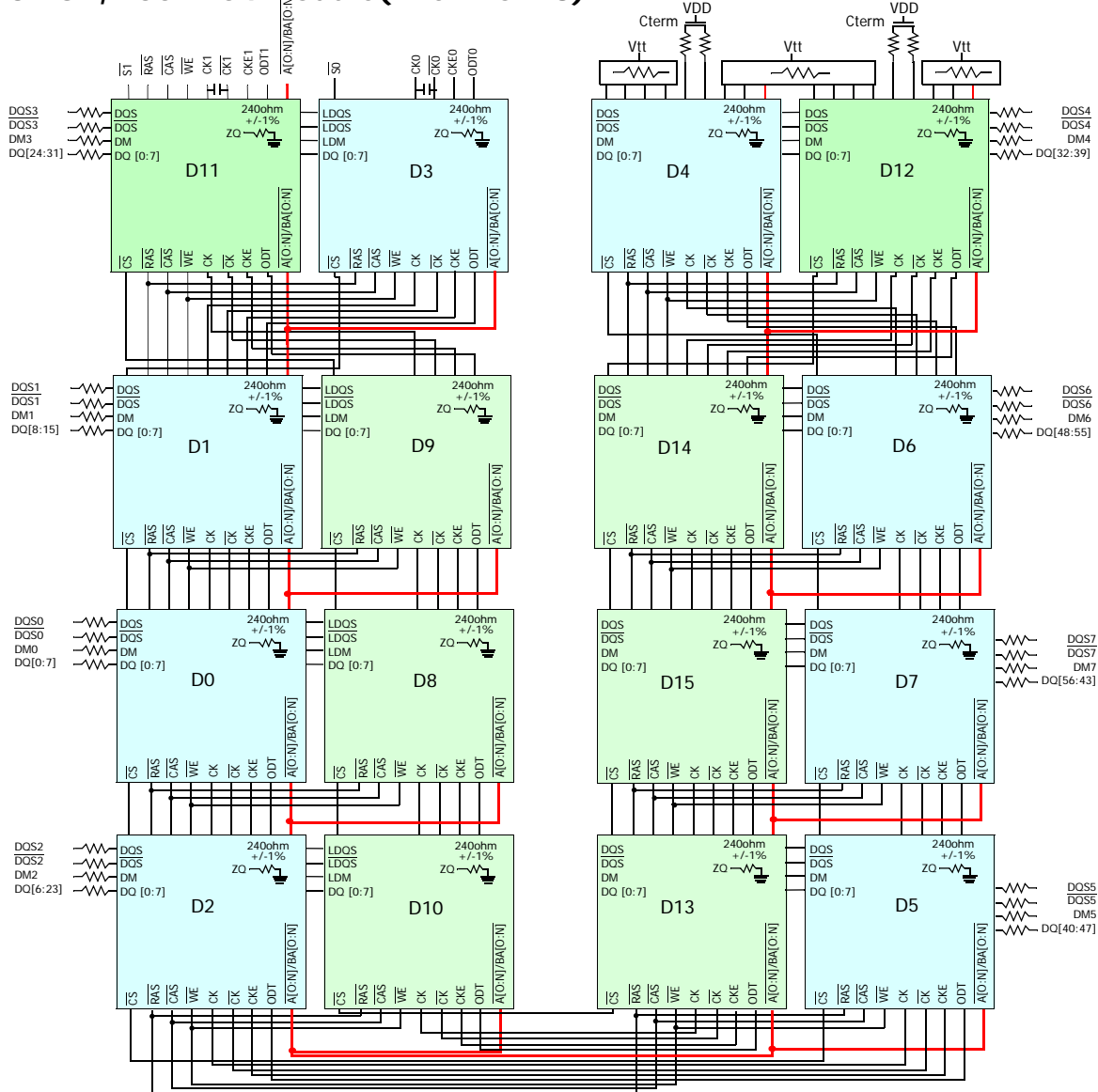

The SPD may be integrated with the Temp Sensor or may be a separate component

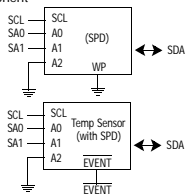

NOTES

1. DQ wiring may differ from that shown however, DQ, DM, DQS, and DQS relationships are maintained as shown

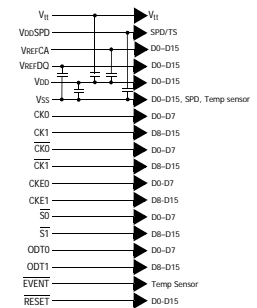
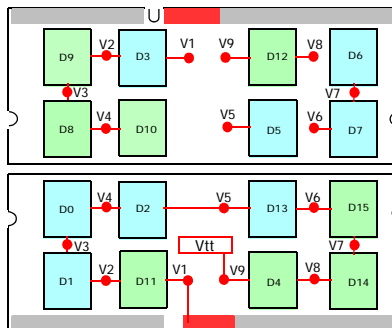

4. ABSOLUTE MAXIMUM RATINGS

4.1 Absolute Maximum DC Ratings

Symbol	Parameter	Rating	Units	Notes
VDD	Voltage on VDD pin relative to Vss	- 0.4 V ~ 1.975 V	V	1,3
VDDQ	Voltage on VDDQ pin relative to Vss	- 0.4 V ~ 1.975 V	V	1,3
VIN, VOUT	Voltage on any pin relative to Vss	- 0.4 V ~ 1.975 V	V	1
TSTG	Storage Temperature	-55 to +100		1, 2

1. Stresses greater than those listed under "Absolute Maximum Ratings" may cause permanent damage to the device. This is a stress rating only and functional operation of the device at these or any other conditions above those indicated in the operational sections of this specification is not implied. Exposure to absolute maximum rating conditions for extended periods may affect reliability.

2. Storage Temperature is the case surface temperature on the center/top side of the DRAM. For the measurement conditions, please refer to JEDEC standard.

3. VDD and VDDQ must be within 300mV of each other at all times; and VREF must be not greater than 0.6XVDDQ, When VDD and VDDQ are less than 500mV; VREF may be equal to or less than 300mV.

4.2 DRAM Component Operating Temperature Range

Symbol	Parameter	Rating	Units	Notes
TOPER	Normal Temperature Range	0 to 85		,2
	Extended Temperature Range	85 to 95		1,3

1. Operating Temperature TOPER is the case surface temperature on the center / top side of the DRAM. For measurement conditions, please refer to the JEDEC document JEDEC51-2.

2. The Normal Temperature Range specifies the temperatures where all DRAM specifications will be supported. During operation, the DRAM case temperature must be maintained between 0 - 85°C under all operating conditions

3. Some applications require operation of the DRAM in the Extended Temperature Range between 85°... and 95°... case temperature.
Full specifications are guaranteed in this range, but the following additional conditions apply:

a) Refresh commands must be doubled in frequency, therefore reducing the Refresh interval tREFI to 3.9 μs. (This double refresh requirement may not apply for some devices.) It is also possible to specify a component with 1X refresh (tREFI to 7.8μs) in the Extended Temperature Range. Please refer to supplier data sheet and/ or the DIMM SPD for option availability.

b) If Self-Refresh operation is required in the Extended Temperature Range, then it is mandatory to either use the Manual Self-Refresh mode with Extended Temperature Range capability (MR2 A6 = 0 and MR2 A7 = 1b) or enable the optional Auto Self-Refresh mode (MR2 A6 = 1b and MR2 A7 = 0b).

5. AC & DC Operating Conditions

5.1 Recommended DC Operating Conditions

Symbol	Parameter	Rating			Units	Notes
		Min.	Typ.	Max.		
VDD	Supply Voltage	1.425	1.500	1.575	V	1,2
VDDQ	Supply Voltage for Output	1.425	1.500	1.575	V	1,2

1. Under all conditions, VDDQ must be less than or equal to VDD.
2. VDDQ tracks with VDD. AC parameters are measured with VDD and VDDQ tied together.

5.2 DC & AC Logic Input Levels

5.2.1 DC & AC Logic Input Levels for Single-Ended Signals

Symbol	Parameter	DDR3-1066, DDR3-1333		Unit	Notes
		Min	Max		
VIH(DC)	DC input logic high	Vref + 0.100	-	V	1, 2
VIL(DC)	DC input logic low		Vref - 0.100	V	1, 2
VIH(AC)	AC input logic high	Vref + 0.175	-	V	1, 2
VIL(AC)	AC input logic low		Vref - 0.175	V	1, 2
VRefDQ (DC)	Reference Voltage for DQ, DM inputs	0.49 * VDD	0.51 * VDD	V	3, 4
VRefCA (DC)	Reference Voltage for ADD, CMD inputs	0.49 * VDD	0.51 * VDD	V	3, 4
VTT	Termination voltage for DQ, DQS outputs	VDDQ/2 - TBD	VDDQ/2 + TBD	V	

1. For DQ and DM, Vref = VrefDQ. For input only pins except RESET#, Vref = VrefCA.
2. The "t.b.d." entries might change based on overshoot and undershoot specification.
3. The ac peak noise on VRef may not allow VRef to deviate from VRef (DC) by more than +/-1% VDD (for reference: approx. +/- 15 mV).
For reference: approx. VDD/2 +/- 15 mV.

The dc-tolerance limits and ac-noise limits for the reference voltages VRefCA and VRefDQ are illustrated in figure 6.2.1. It shows a valid reference voltage VRef (t) as a function of time. (VRef stands for VRefCA and VRefDQ likewise). VRef(DC) is the linear average of VRef (t) over a very long period of time (e.g. 1 sec). This average has to meet the min/max requirements in Table 1. Furthermore VRef (t) may temporarily deviate from VRef (DC) by no more than +/- 1% VDD.

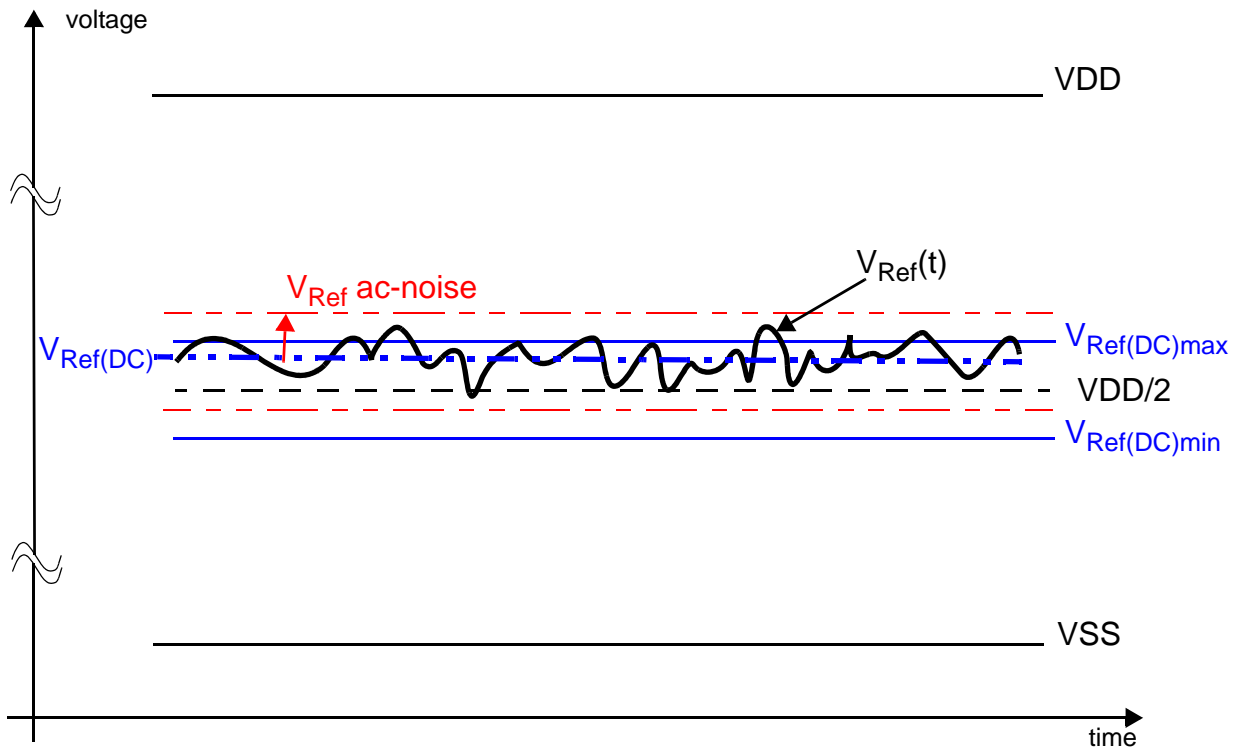

< Figure 6.2.1: Illustration of Vref (DC) tolerance and Vref AC-noise limits >

The voltage levels for setup and hold time measurements $V_{IH}(AC)$, $V_{IH}(DC)$, $V_{IL}(AC)$ and $V_{IL}(DC)$ are dependent on V_{Ref} . "VRef" shall be understood as $V_{Ref}(DC)$, as defined in Figure 6.2.1

This clarifies, that dc-variations of V_{Ref} affect the absolute voltage a signal has to reach to achieve a valid high or low level and therefore the time to which setup and hold is measured. System timing and voltage budgets need to account for $V_{Ref}(DC)$ deviations from the optimum position within the data-eye of the input signals.

This also clarifies that the DRAM setup/hold specification and derating values need to include time and voltage associated with V_{Ref} ac-noise. Timing and voltage effects due to ac-noise on V_{Ref} up to the specified limit ($\pm 1\%$ of V_{DD}) are included in DRAM timings and their associated deratings.

5.2.2 DC & AC Logic Input Levels for Differential Signals

Symbol	Parameter	DDR3-1066, DDR3-1333		Unit	Notes
		Min	Max		
V_{IHdiff}	Differential input logic high	+ 0.200	-	V	1
V_{ILdiff}	Differential input logic low		- 0.200	V	1

Note1:

Refer to "Overshoot and Undershoot Specification section 6.5 on 26 page

5.2.3 Differential Input Cross Point Voltage

To guarantee tight setup and hold times as well as output skew parameters with respect to clock and strobe, each cross point voltage of differential input signals (CK, CK# and DQS, DQS#) must meet the requirements in Table 6.2.3. The differential input cross point voltage V_{IX} is measured from the actual cross point of true and complement signal to the midlevel between of VDD and VSS.

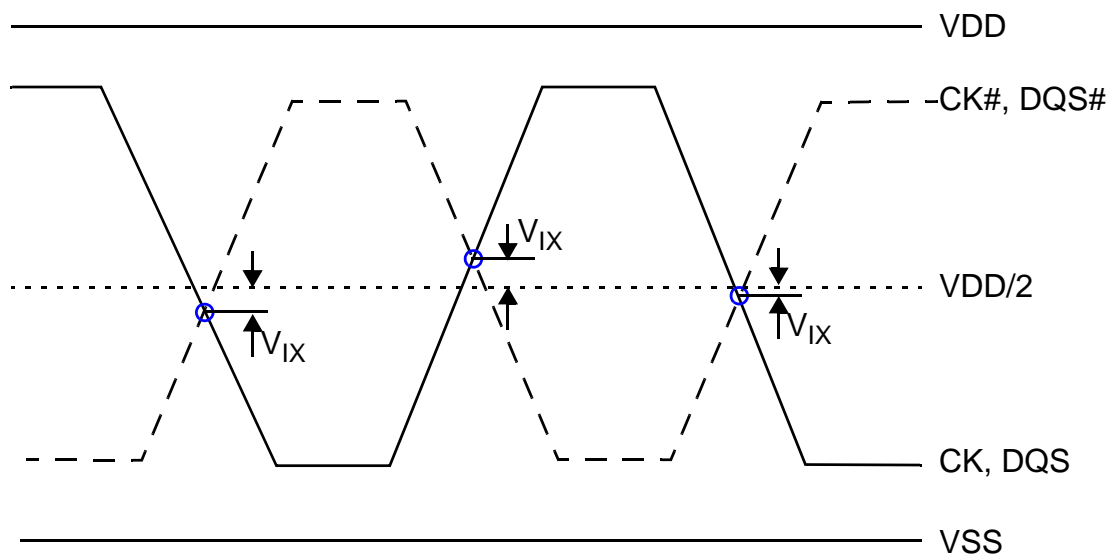

< Figure 5.2.3 V_{IX} Definition >

Symbol	Parameter	DDR3-1066, DDR3-1333		Unit	Notes
		Min	Max		
V_{IX}	Differential Input Cross Point Voltage relative to VDD/2	- 150	+ 150	mV	

< Table 5.2.3: Cross point voltage for differential input signals (CK, DQS) >

5.3 Slew Rate Definitions

5.3.1 For Single Ended Input Signals

- Input Slew Rate for Input Setup Time (tIS) and Data Setup Time (tDS)

Setup (tIS and tDS) nominal slew rate for a rising signal is defined as the slew rate between the last crossing of VRef and the first crossing of VIH (AC) min. Setup (tIS and tDS) nominal slew rate for a falling signal is defined as the slew rate between the last crossing of VRef and the first crossing of VIL (AC) max.

- Input Slew Rate for Input Hold Time (tIH) and Data Hold Time (tDH)

Hold nominal slew rate for a rising signal is defined as the slew rate between the last crossing of VIL (DC) max and the first crossing of VRef. Hold (tIH and tDH) nominal slew rate for a falling signal is defined as the slew rate between the last crossing of VIH (DC) min and the first crossing of VRef.

Description	Measured		Defined by	Applicable for
	Min	Max		
Input slew rate for rising edge	Vref	VIH (AC) min	$\frac{VIH (AC) \text{ min} - Vref}{\Delta TRS}$	Setup (tIS, tDS)
Input slew rate for falling edge	Vref	VIL (AC) max	$\frac{Vref - VIL (AC) \text{ max}}{\Delta TFS}$	
Input slew rate for rising edge	VIL (DC) max	Vref	$\frac{Vref - VIL (DC) \text{ max}}{\Delta TFH}$	Hold (tIH, tDH)
Input slew rate for falling edge	VIH (DC) min	Vref	$\frac{VIH (DC) \text{ min} - Vref}{\Delta TRH}$	

< Table 5.3.1: Single-Ended Input Slew Rate Definition >

Part A: Set up

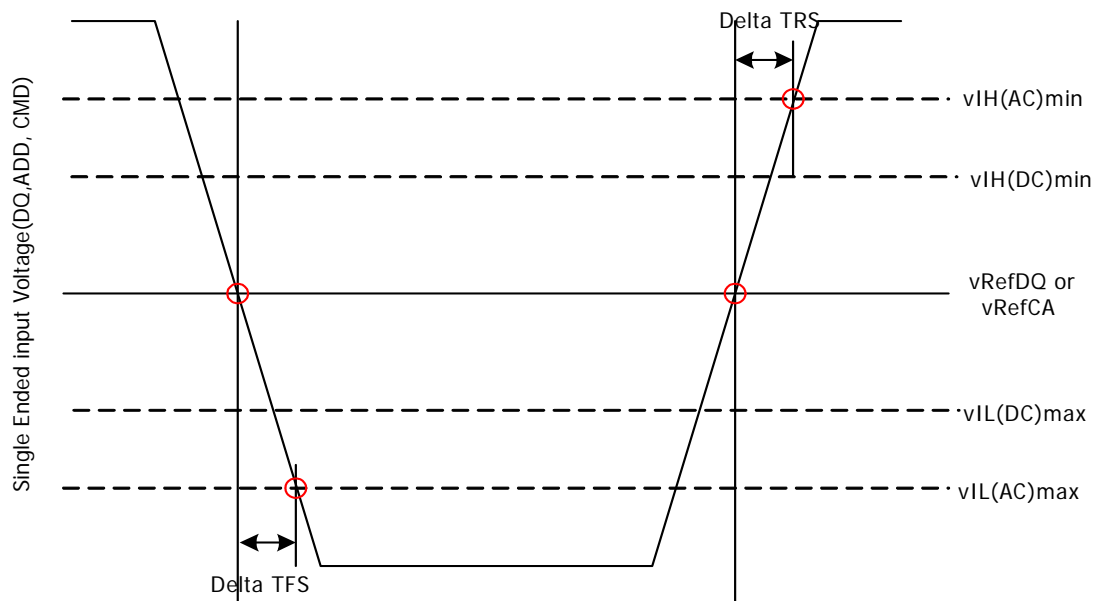

Part B: Hold

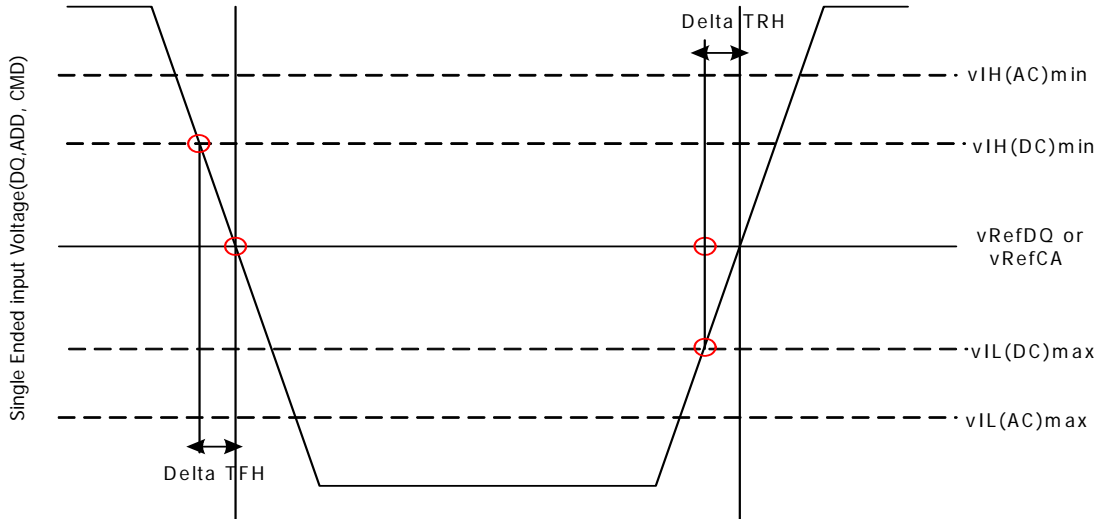

< Figure 5.3.1: Input Nominal Slew Rate Definition for Single-Ended Signals >

5.3.2 Differential Input Signals

Input slew rate for differential signals (CK, CK# and DQS, DQS#) are defined and measured as shown in below Table and Figure .

Description	Measured		Defined by
	Min	Max	
Differential input slew rate for rising edge (CK-CK and DQS-DQS)	VILdiffmax	VIHdiffmin	$\frac{VIHdiffmin - VILdiffmax}{\Delta TRdiff}$
Differential input slew rate for falling edge (CK-CK and DQS-DQS)	VIHdiffmin	VILdiffmax	$\frac{VIHdiffmin - VILdiffmax}{\Delta TFdiff}$

Note:

The differential signal (i.e. CK-CK and DQS-DQS) must be linear between these thresholds.

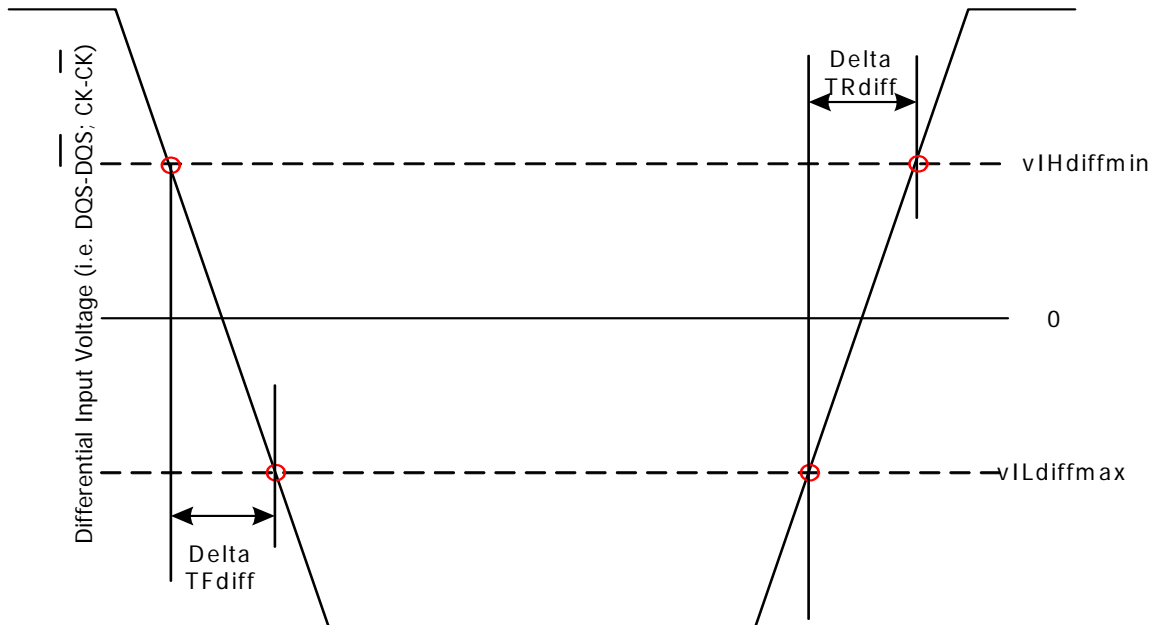

< Figure 5.3.2: Differential Input Slew Rate Definition for DQS,DQS# and CK,CK# >

5.4 DC & AC Output Buffer Levels

5.4.1 Single Ended DC & AC Output Levels

Below table shows the output levels used for measurements of single ended signals.

Symbol	Parameter	DDR3-1066, 1333	Unit	Notes
VOH(DC)	DC output high measurement level (for IV curve linearity)	0.8 x VDDQ	V	
VOM(DC)	DC output mid measurement level (for IV curve linearity)	0.5 x VDDQ	V	
VOL(DC)	DC output low measurement level (for IV curve linearity)	0.2 x VDDQ	V	
VOH(AC)	AC output high measurement level (for output SR)	VTT + 0.1 x VDDQ	V	1
VOL(AC)	AC output low measurement level (for output SR)	VTT - 0.1 x VDDQ	V	1

1. The swing of $\pm 0.1 \times VDDQ$ is based on approximately 50% of the static single ended output high or low swing with a driver impedance of 40 Ω and an effective test load of 25 Ω to $VTT = VDDQ / 2$.

5.4.2 Differential DC & AC Output Levels

Below table shows the output levels used for measurements of differential signals.

Symbol	Parameter	DDR3-1066, 1333	Unit	Notes
VOHdiff (AC)	AC differential output high measurement level (for output SR)	+ 0.2 x VDDQ	V	1
VOLdiff (AC)	AC differential output low measurement level (for output SR)	- 0.2 x VDDQ	V	1

1. The swing of $\approx 0.2 \times VDDQ$ is based on approximately 50% of the static differential output high or low swing with a driver impedance of 40Ω and an effective test load of 25Ω to $VTT = VDDQ/2$ at each of the differential output

5.4.3 Single Ended Output Slew Rate

With the reference load for timing measurements, output slew rate for falling and rising edges is defined and measured between VOL(AC) and VOH(AC) for single ended signals as shown in below Table and Figure 6.4.3.

Description	Measured		Defined by
	From	To	
Single ended output slew rate for rising edge	VOL(AC)	VOH(AC)	$\frac{VOH(AC)-VOL(AC)}{\Delta TRse}$
Single ended output slew rate for falling edge	VOH(AC)	VOL(AC)	$\frac{VOH(AC)-VOL(AC)}{\Delta TFse}$

Note:

Output slew rate is verified by design and characterisation, and may not be subject to production test.

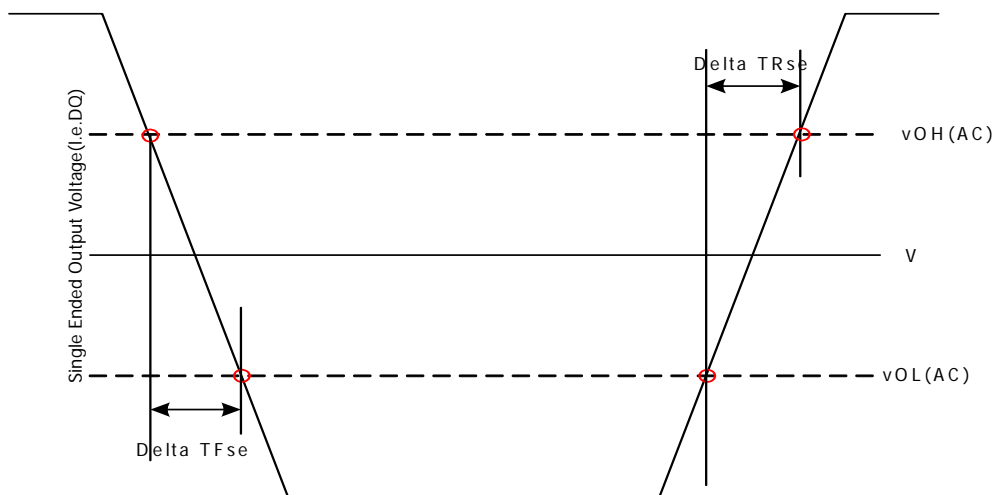

< Figure 5.4.3: Single Ended Output Slew Rate Definition >

Parameter	Symbol	DDR3-1066		DDR3-1333		Units
		Min	Max	Min	Max	
Single-ended Output Slew Rate	SRQse	2.5	5	2.5	5	V/ns

*** Description:
SR: Slew Rate
Q: Query Output (like in DQ, which stands for Data-in, Query-Output)
For Ron = RZQ/7 setting

< Table 5.4.3: Output Slew Rate (single-ended) >

5.4.4 Differential Output Slew Rate

With the reference load for timing measurements, output slew rate for falling and rising edges is defined and measured between VOLdiff (AC) and VOHdiff (AC) for differential signals as shown in below Table and Figure 5.4.4

Description	Measured		Defined by
	From	To	
Differential output slew rate for rising edge	VOHdiff (AC)	VOHdiff (AC)	$\frac{VOHdiff(AC) - VOLdiff(AC)}{\Delta TRdiff}$
Differential output slew rate for falling edge	VOHdiff (AC)	VOLdiff (AC)	$\frac{VOHdiff(AC) - VOLdiff(AC)}{\Delta TFdiff}$

Note: Output slew rate is verified by design and characterization, and may not be subject to production test..

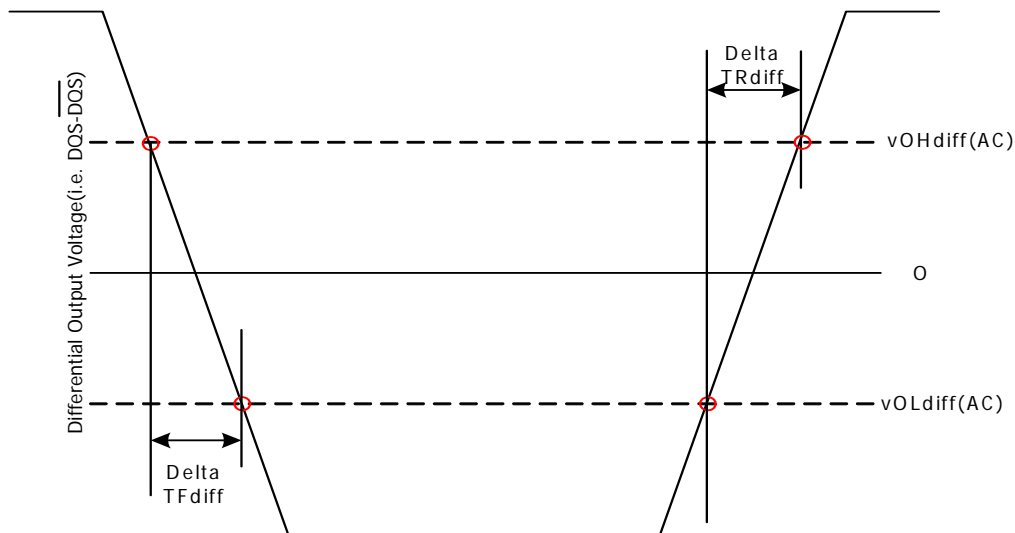

< Figure 5.4.4: Differential Output Slew Rate Definition >

Parameter	Symbol	DDR3-1066		DDR3-1333		Units
		Min	Max	Min	Max	
Differential Output Slew Rate	SRQdiff	5	10	5	10	V/ns

***Description:

SR: Slew Rate

Q: Query Output (like in DQ, which stands for Data-in, Query-Output)

diff: Differential Signals

For Ron = RZQ/7 setting

< Table 5.4.4: Differential Output Slew Rate >

5.5 Overshoot and Undershoot Specifications

5.5.1 Address and Control Overshoot and Undershoot Specifications

Description	Specification	
	DDR3-1066	DDR3-1333
Maximum peak amplitude allowed for overshoot area (see Figure)	0.4V	0.4V
Maximum peak amplitude allowed for undershoot area (see Figure)	0.4V	0.4V
Maximum overshoot area above VDD (See Figure)	0.5 V-ns	0.4 V-ns
Maximum undershoot area below VSS (See Figure)	0.5 V-ns	0.4 V-ns

< Table 5.5.1: AC Overshoot/Undershoot Specification for Address and Control Pins >

< Figure 5.5.1: Address and Control Overshoot and Undershoot Definition >

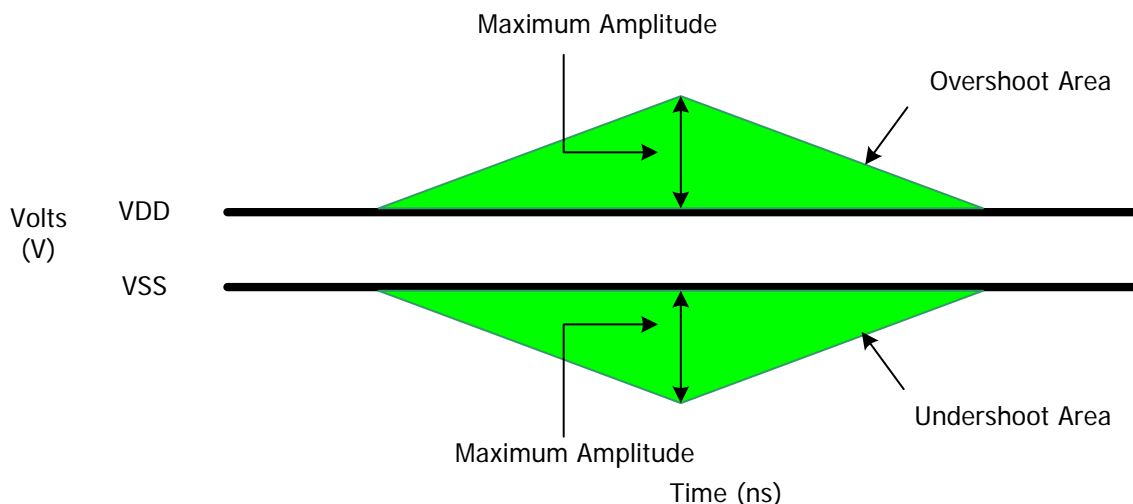

5.5.2 Clock, Data, Strobe and Mask Overshoot and Undershoot Specifications

Description	Specification	
	DDR3-1066	DDR3-1333
Maximum peak amplitude allowed for overshoot area (see Figure)	0.4V	0.4V
Maximum peak amplitude allowed for undershoot area (see Figure)	0.4V	0.4V
Maximum overshoot area above VDDQ (See Figure)	0.19 V-ns	0.15 V-ns
Maximum undershoot area below VSSQ (See Figure)	0.19 V-ns	0.15 V-ns

< Table 5.5.2: AC Overshoot/Undershoot Specification for Clock, Data, Strobe and Mask >

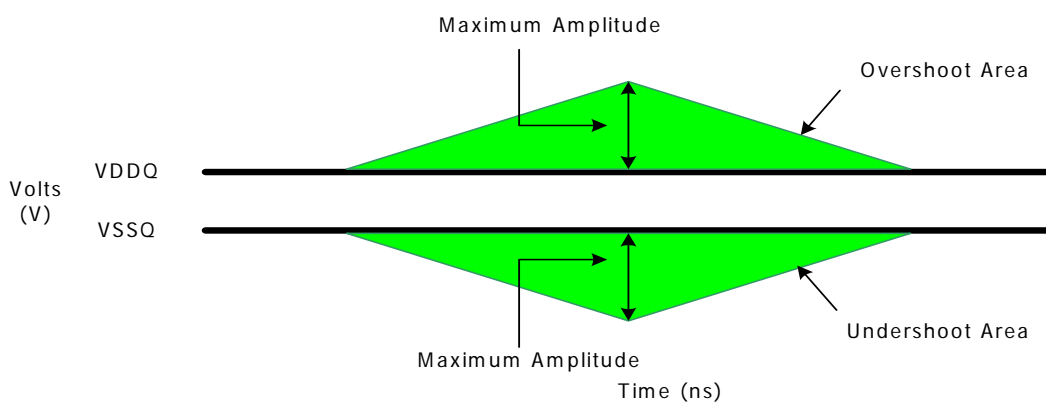

Clock, Data Strobe and Mask Overshoot and Undershoot Definition

< Figure 5.5.2: Clock, Data, Strobe and Mask Overshoot and Undershoot Definition >

5.6 Pin Capacitance

Parameter	Symbol	DDR3-1066		DDR3-1333		Units	Notes
		Min	Max	Min	Max		
Input/output capacitance (DQ, DM, DQS, DQS#, TDQS, TDQS#)	C_{IO}	TBD	TBD	TBD	TBD	pF	1,2,3
Input capacitance, CK and CK#	C_{CK}	TBD	TBD	TBD	TBD	pF	2,3,5
Input capacitance delta CK and CK#	C_{DCK}	TBD	TBD	TBD	TBD	pF	2,3,4
Input capacitance (All other input-only pins)	C_I	TBD	TBD	TBD	TBD	pF	2,3,6
Input capacitance delta, DQS and DQS#	C_{DDQS}	TBD	TBD	TBD	TBD	pF	2,3,12
Input capacitance delta (All CTRL input-only pins)	C_{DI_CTRL}	TBD	TBD	TBD	TBD	pF	2,3,7,8
Input capacitance delta (All ADD/CMD input-only pins)	$C_{DI_ADD_CMD}$	TBD	TBD	TBD	TBD	pF	2,3,9,10
Input/output capacitance delta (DQ, DM, DQS, DQS#)	C_{DIO}	TBD	TBD	TBD	TBD	pF	2,3,11

Notes:

- TDQS/TDQS# are not necessarily input function but since TDQS is sharing DM pin and the parasitic characterization of TDQS/TDQS# should be close as much as possible, C_{IO} & C_{DIO} requirement is applied (recommend deleting note or changing to "Although the DM, TDQS and TDQS# pins have different functions, the loading matches DQ and DQS.")
- This parameter is not subject to production test. It is verified by design and characterization. Input capacitance is measured according to JEP147("PROCEDURE FOR MEASURING INPUT CAPACITANCE USING A VECTOR NETWORK ANALYZER(VNA)") with VDD, VDDQ, VSS, VSSQ applied and all other pins floating (except the pin under test, CKE, RESET# and ODT as necessary). VDD=VDDQ=1.5V, VBIAS=VDD/2 and on-die termination off.
- This parameter applies to monolithic devices only; stacked/dual-die devices are not covered here
- Absolute value of $C_{CK}-C_{CK\#}$.
- The minimum C_{CK} will be equal to the minimum C_I .
- Input only pins include: ODT, CS, CKE, A0-A15, BA0-BA2, RAS#, CAS#, WE#.
- CTRL pins defined as ODT, CS and CKE.
- $C_{DI_CTRL}=C_I(CTRL) - 0.5 * C_I(CLK) + C_I(CLK\#)$
- ADD pins defined as A0-A15, BA0-BA2 and CMD pins are defined as RAS#, CAS# and WE#.
- $C_{DI_ADD_CMD}=C_I(ADD_CMD) - 0.5*(C_I(CLK)+C_I(CLK\#))$
- $C_{DIO}=C_{IO}(DQ) - 0.5*(C_{IO}(DQS)+C_{IO}(DQS\#))$
- Absolute value of $C_{IO}(DQS) - C_{IO}(DQS\#)$

5.7 IDD Specifications (T_{CASE} : 0 to 95°C)

512MB, 64M x 64 SO-DIMM: HMT164S6BFR6C

Speed Grade Bin	DDR3 - 1066 7-7-7	DDR3 - 1333 9-9-9	Unit	Notes
Symbol	Max.	Max.		
I_{DD0}	400	420	mA	
I_{DD1}	500	520	mA	
I_{DD2N}	200	220	mA	
I_{DD2NT}	200	220	mA	
I_{DD2P0}	40	40	mA	
I_{DD2P1}	140	140	mA	
I_{DD2Q}	200	220	mA	
I_{DD3N}	280	300	mA	
I_{DD3P}	140	160	mA	
I_{DD4R}	780	860	mA	
I_{DD4W}	780	860	mA	
I_{DD5B}	720	720	mA	
I_{DD6}	40	40	mA	
I_{DD6ET}	48	48	mA	
I_{DD6TC}	48	48	mA	
I_{DD7}	840	1040	mA	

1GB, 128M x 64 SO-DIMM: HMT112S6BFR6C

Speed Grade Bin	DDR3 - 1066 7-7-7	DDR3 - 1333 9-9-9	Unit	Notes
Symbol	Max.	Max.		
I_{DD0}	600	640	mA	
I_{DD1}	700	740	mA	
I_{DD2N}	400	440	mA	
I_{DD2NT}	400	440	mA	
I_{DD2P0}	80	80	mA	
I_{DD2P1}	280	280	mA	
I_{DD2Q}	400	440	mA	
I_{DD3N}	560	600	mA	
I_{DD3P}	280	320	mA	
I_{DD4R}	980	1080	mA	
I_{DD4W}	980	1080	mA	
I_{DD5B}	920	940	mA	
I_{DD6}	80	80	mA	
I_{DD6ET}	96	96	mA	
I_{DD6TC}	96	96	mA	
I_{DD7}	1040	1260	mA	

2GB, 256M x 64 SO-DIMM: HMT125S6BFR8C

Speed Grade Bin	DDR3 - 1066 7-7-7	DDR3 - 1333 9-9-9	Unit	Notes
Symbol	Max.	Max.		
I_{DD0}	1000	1080	mA	
I_{DD1}	1080	1200	mA	
I_{DD2N}	800	880	mA	
I_{DD2NT}	800	880	mA	
I_{DD2P0}	160	160	mA	
I_{DD2P1}	400	480	mA	
I_{DD2Q}	800	880	mA	
I_{DD3N}	960	1040	mA	
I_{DD3P}	480	480	mA	
I_{DD4R}	1360	1520	mA	
I_{DD4W}	1360	1520	mA	
I_{DD5B}	1760	1800	mA	
I_{DD6}	160	160	mA	
I_{DD6ET}	192	192	mA	
I_{DD6TC}	192	192	mA	
I_{DD7}	1680	2040	mA	

5.7 IDD Measurement Conditions

In this chapter, IDD and IDDQ measurement conditions such as test load and patterns are defined. Figure 1. shows the setup and test load for IDD and IDDQ measurements.

- IDD currents (such as IDD0, IDD1, IDD2N, IDD2NT, IDD2P0, IDD2P1, IDD2Q, IDD3N, IDD3P, IDD4R, IDD4W, IDD5B, IDD6, IDD6ET, IDD6TC and IDD7) are measured as time-averaged currents with all VDD balls of the DDR3 SDRAM under test tied together. Any IDDQ current is not included in IDD currents.
- IDDQ currents (such as IDDQ2NT and IDDQ4R) are measured as time-averaged currents with all VDDQ balls of the DDR3 SDRAM under test tied together. Any IDD current is not included in IDDQ currents.
Attention: IDDQ values cannot be directly used to calculate IO power of the DDR3 SDRAM. They can be used to support correlation of simulated IO power to actual IO power as outlined in Figure 2. In DRAM module application, IDDQ cannot be measured separately since VDD and VDDQ are using one merged-power layer in Module PCB.

For IDD and IDDQ measurements, the following definitions apply:

- "0" and "LOW" is defined as $V_{IN} \leq V_{ILAC(max)}$.
- "1" and "HIGH" is defined as $V_{IN} \geq V_{IHAC(max)}$.
- "FLOATING" is defined as inputs are $V_{REF} - V_{DD}/2$.
- Timing used for IDD and IDDQ Measurement-Loop Patterns are provided in Table 1 on Page 26.
- Basic IDD and IDDQ Measurement Conditions are described in Table 2 on page 26.
- Detailed IDD and IDDQ Measurement-Loop Patterns are described in Table 3 on page 30 through Table 10 on page 36.
- IDD Measurements are done after properly initializing the DDR3 SDRAM. This includes but is not limited to setting
 $RON = RZQ/7$ (34 Ohm in MR1);
 $Qoff = 0_B$ (Output Buffer enabled in MR1);
 $RTT_Nom = RZQ/6$ (40 Ohm in MR1);
 $RTT_Wr = RZQ/2$ (120 Ohm in MR2);
TDQS Feature disabled in MR1
- Attention: The IDD and IDDQ Measurement-Loop Patterns need to be executed at least one time before actual IDD or IDDQ measurement is started.
- Define $\bar{D} = \{\overline{CS}, \overline{RAS}, \overline{CAS}, \overline{WE}\} = \{HIGH, LOW, LOW, LOW\}$
- Define $\bar{D} = \{\overline{CS}, \overline{RAS}, \overline{CAS}, \overline{WE}\} = \{HIGH, HIGH, HIGH, HIGH\}$

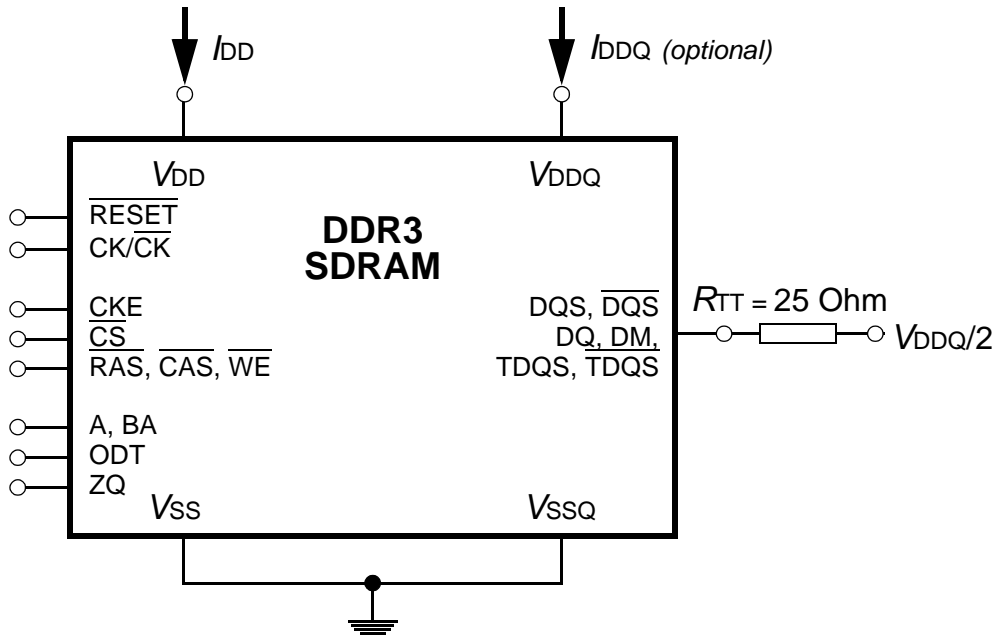

Figure 1 - Measurement Setup and Test Load for IDD and IDDQ (optional) Measurements
[Note: DIMM level Output test load condition may be different from above]

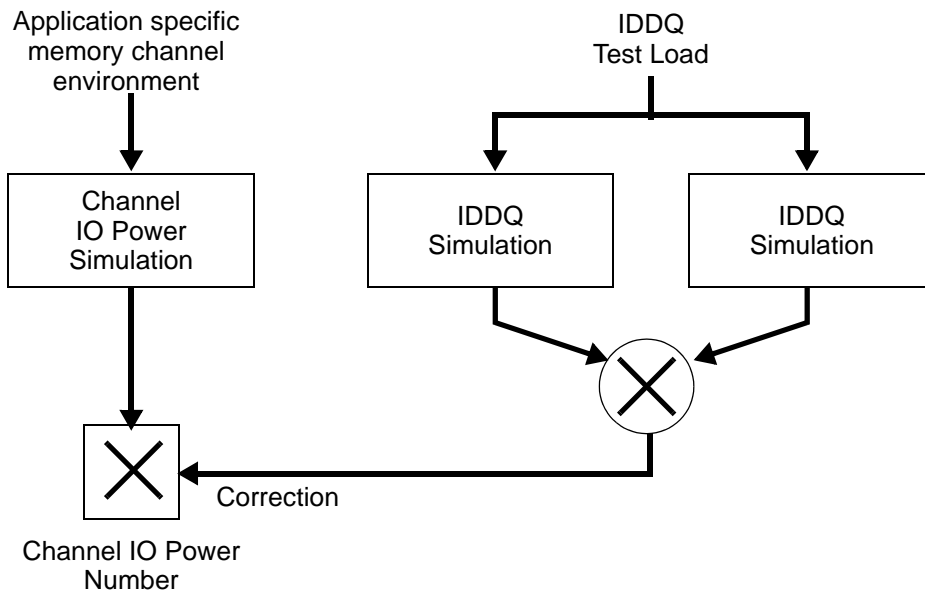

Figure 2 - Correlation from simulated Channel IO Power to actual Channel IO Power supported by IDDQ Measurement

Table 1 -Timings used for IDD and IDDQ Measurement-Loop Patterns

Symbol	DDR3-1066		DDR3-1333		Unit
	7-7-7		9-9-9		
t_{CK}	1.875		1.5		ns
CL	7		9		nCK
n_{RCD}	7		9		nCK
n_{RC}	27		33		nCK
n_{RAS}	20		24		nCK
n_{RP}	7		9		nCK
n_{FAW}	x4/x8	20	20		nCK
	x16	27	30		nCK
n_{RRD}	x4/x8	4	4		nCK
	x16	6	5		nCK
n_{RFC} -512Mb	48		60		nCK
n_{RFC} -1 Gb	59		74		nCK
n_{RFC} - 2 Gb	86		107		nCK
n_{RFC} - 4 Gb	160		200		nCK
n_{RFC} - 8 Gb	187		234		nCK

Table 2 -Basic IDD and IDDQ Measurement Conditions

Symbol	Description
I_{DD0}	Operating One Bank Active-Precharge Current CKE: High; External clock: On; t_{CK} , n_{RC} , n_{RAS} , CL: see Table 1 on page 26; BL: 8 ^a); AL: 0; \overline{CS} : High between ACT and PRE; Command, Address, Bank Address Inputs: partially toggling according to Table 3 on page 30; Data IO: FLOATING; DM: stable at 0; Bank Activity: Cycling with one bank active at a time: 0,0,1,1,2,2,... (see Table 3 on page 30); Output Buffer and RTT: Enabled in Mode Registers ^b); ODT Signal: stable at 0; Pattern Details: see Table 3 on page 30
I_{DD1}	Operating One Bank Active-Precharge Current CKE: High; External clock: On; t_{CK} , n_{RC} , n_{RAS} , n_{RCD} , CL: see Table 1 on page 26; BL: 8 ^a); AL: 0; \overline{CS} : High between ACT, RD and PRE; Command, Address; Bank Address Inputs, Data IO: partially toggling according to Table 4 on page 31; DM: stable at 0; Bank Activity: Cycling with on bank active at a time: 0,0,1,1,2,2,... (see Table 4 on page 31); Output Buffer and RTT: Enabled in Mode Registers ^b); ODT Signal: stable at 0; Pattern Details: see Table 4 page 31

I_{DD2N}	<p>Precharge Standby Current</p> <p>CKE: High; External clock: On; tCK, CL: see Table 1 on page 26; BL: 8^{a)}; AL: 0; \overline{CS}: stable at 1; Command, Address, Bank Address Inputs: partially toggling according to Table 5 on page 32; Data IO: FLOATING; DM: stable at 0; Bank Activity: all banks closed; Output Buffer and RTT: Enabled in Mode Registers^{b)}; ODT Signal: stable at 0; Pattern Details: see Table 5 on page 32</p>
I_{DD2NT}	<p>Precharge Standby ODT Current</p> <p>CKE: High; External clock: On; tCK, CL: see Table 1 on page 26; BL: 8^{a)}; AL: 0; \overline{CS}: stable at 1; Command, Address, Bank Address Inputs: partially toggling according to Table 6 on page 32; Data IO: FLOATING; DM: stable at 0; Bank Activity: all banks closed; Output Buffer and RTT: Enabled in Mode Registers^{b)}; ODT Signal: toggling according to Table 6 on page 32; Pattern Details: see Table 6 on page 32</p>
I_{DDQ2NT} (optional)	<p>Precharge Standby ODT IDDQ Current</p> <p>Same definition like for IDD2NT, however measuring IDDQ current instead of IDD current</p>
I_{DD2P0}	<p>Precharge Power-Down Current Slow Exit</p> <p>CKE: Low; External clock: On; tCK, CL: see Table 1 on page 26; BL: 8^{a)}; AL: 0; \overline{CS}: stable at 1; Command, Address, Bank Address Inputs: stable at 0; Data IO: FLOATING; DM: stable at 0; Bank Activity: all banks closed; Output Buffer and RTT: Enabled in Mode Registers^{b)}; ODT Signal: stable at 0; Precharge Power Down Mode: Slow Exit^{c)}</p>
I_{DD2P1}	<p>Precharge Power-Down Current Fast Exit</p> <p>CKE: Low; External clock: On; tCK, CL: see Table 1 on page 26; BL: 8^{a)}; AL: 0; \overline{CS}: stable at 1; Command, Address, Bank Address Inputs: stable at 0; Data IO: FLOATING; DM: stable at 0; Bank Activity: all banks closed; Output Buffer and RTT: Enabled in Mode Registers^{b)}; ODT Signal: stable at 0; Precharge Power Down Mode: Fast Exit^{c)}</p>
I_{DD2Q}	<p>Precharge Quiet Standby Current</p> <p>CKE: High; External clock: On; tCK, CL: see Table 1 on page 26; BL: 8^{a)}; AL: 0; \overline{CS}: stable at 1; Command, Address, Bank Address Inputs: stable at 0; Data IO: FLOATING; DM: stable at 0; Bank Activity: all banks closed; Output Buffer and RTT: Enabled in Mode Registers^{b)}; ODT Signal: stable at 0</p>
I_{DDQ4R} (optional)	<p>Operating Burst Read IDDQ Current</p> <p>Same definition like for IDD4R, however measuring IDDQ current instead of IDD current</p>

I_{DD3N}	<p>Active Standby Current</p> <p>CKE: High; External clock: On; tCK, CL: see Table 1 on page 26; BL: 8^{a)}; AL: 0; \overline{CS}: stable at 1; Command, Address, Bank Address Inputs: partially toggling according to Table 5 on page 32; Data IO: FLOATING; DM: stable at 0; Bank Activity: all banks open; Output Buffer and RTT: Enabled in Mode Registers^{b)}; ODT Signal: stable at 0; Pattern Details: see Table 5 on page 32</p>
I_{DD3P}	<p>Active Power-Down Current</p> <p>CKE: Low; External clock: On; tCK, CL: see Table 1 on page 26; BL: 8^{a)}; AL: 0; \overline{CS}: stable at 1; Command, Address, Bank Address Inputs: stable at 0; Data IO: FLOATING; DM: stable at 0; Bank Activity: all banks open; Output Buffer and RTT: Enabled in Mode Registers^{b)}; ODT Signal: stable at 0</p>
I_{DD4R}	<p>Operating Burst Read Current</p> <p>CKE: High; External clock: On; tCK, CL: see Table 1 on page 26; BL: 8^{a)}; AL: 0; \overline{CS}: High between RD; Command, Address, Bank Address Inputs: partially toggling according to Table 7 on page 33; Data IO: seamless read data burst with different data between one burst and the next one according to Table 7 on page 33; DM: stable at 0; Bank Activity: all banks open, RD commands cycling through banks: 0,0,1,1,2,2,...(see Table 7 on page 33); Output Buffer and RTT: Enabled in Mode Registers^{b)}; ODT Signal: stable at 0; Pattern Details: see Table 7 on page 33</p>
I_{DD4W}	<p>Operating Burst Write Current</p> <p>CKE: High; External clock: On; tCK, CL: see Table 1 on page 26; BL: 8^{a)}; AL: 0; \overline{CS}: High between WR; Command, Address, Bank Address Inputs: partially toggling according to Table 8 on page 34; Data IO: seamless read data burst with different data between one burst and the next one according to Table 8 on page 34; DM: stable at 0; Bank Activity: all banks open, WR commands cycling through banks: 0,0,1,1,2,2,...(see Table 8 on page 34); Output Buffer and RTT: Enabled in Mode Registers^{b)}; ODT Signal: stable at HIGH; Pattern Details: see Table 8 on page 34</p>
I_{DD5B}	<p>Burst Refresh Current</p> <p>CKE: High; External clock: On; tCK, CL, nRFC: see Table 1 on page 26; BL: 8^{a)}; AL: 0; \overline{CS}: High between REF; Command, Address, Bank Address Inputs: partially toggling according to Table 9 on page 35; Data IO: FLOATING; DM: stable at 0; Bank Activity: REF command every nREF (see Table 9 on page 35); Output Buffer and RTT: Enabled in Mode Registers^{b)}; ODT Signal: stable at 0; Pattern Details: see Table 9 on page 35</p>

I_{DD6}	<p>Self-Refresh Current: Normal Temperature Range</p> <p>T_{CASE}: 0 - 85 °C; Auto Self-Refresh (ASR): Disabled^d; Self-Refresh Temperature Range (SRT): Normal^e; CKE: Low; External clock: Off; CK and \overline{CK}: LOW; CL: see Table 1 on page 26; BL: 8^a; AL: 0; \overline{CS}, Command, Address, Bank Address Inputs, Data IO: FLOATING; DM: stable at 0; Bank Activity: Self-Refresh operation; Output Buffer and RTT: Enabled in Mode Registers^b; ODT Signal: FLOATING</p>
I_{DD6ET}	<p>Self-Refresh Current: Extended Temperature Range (optional)^f</p> <p>T_{CASE}: 0 - 95 °C; Auto Self-Refresh (ASR): Disabled^d; Self-Refresh Temperature Range (SRT): Extended^e; CKE: Low; External clock: Off; CK and \overline{CK}: LOW; CL: see Table 1 on page 26; BL: 8^a; AL: 0; \overline{CS}, Command, Address, Bank Address Inputs, Data IO: FLOATING; DM: stable at 0; Bank Activity: Extended Temperature Self-Refresh operation; Output Buffer and RTT: Enabled in Mode Registers^b; ODT Signal: FLOATING</p>
I_{DD6TC}	<p>Auto Self-Refresh Current (optional)^f</p> <p>T_{CASE}: 0 - 95 °C; Auto Self-Refresh (ASR): Enabled^d; Self-Refresh Temperature Range (SRT): Normal^e; CKE: Low; External clock: Off; CK and \overline{CK}: LOW; CL: see Table 1 on page 26; BL: 8^a; AL: 0; \overline{CS}, Command, Address, Bank Address Inputs, Data IO: FLOATING; DM: stable at 0; Bank Activity: Auto Self-Refresh operation; Output Buffer and RTT: Enabled in Mode Registers^b; ODT Signal: FLOATING</p>
I_{DD7}	<p>Operating Bank Interleave Read Current</p> <p>CKE: High; External clock: On; tCK, nRC, nRAS, nRCD, NRRD, nFAW, CL: see Table 1 on page 26; BL: 8^a; AL: CL-1; \overline{CS}: High between ACT and RDA; Command, Address, Bank Address Inputs: partially toggling according to Table 10 on page 36; Data IO: read data burst with different data between one burst and the next one according to Table 10 on page 36; DM: stable at 0; Bank Activity: two times interleaved cycling through banks (0, 1,...7) with different addressing, see Table 10 on page 36; Output Buffer and RTT: Enabled in Mode Registers^b; ODT Signal: stable at 0; Pattern Details: see Table 10 on page 36</p>

a) Burst Length: BL8 fixed by MRS: set MR0 A[1,0]=00B

b) Output Buffer Enable: set MR1 A[12] = 0B; set MR1 A[5,1] = 01B; RTT_Nom enable: set MR1 A[9,6,2] = 011B; RTT_Wr enable: set MR2 A[10,9] = 10B

c) Precharge Power Down Mode: set MR0 A12=0B for Slow Exit or MR0 A12 = 1B for Fast Exit

d) Auto Self-Refresh (ASR): set MR2 A6 = 0B to disable or 1B to enable feature

e) Self-Refresh Temperature Range (SRT): set MR2 A7 = 0B for normal or 1B for extended temperature range

f) Refer to DRAM supplier data sheet and/or DIMM SPD to determine if optional features or requirements are supported by DDR3 SDRAM device

Table 3 - IDD0 Measurement-Loop Pattern^{a)}

CK, CK	CKE	Sub-Loop	Cycle Number	Command	$\overline{\text{CS}}$	$\overline{\text{RAS}}$	$\overline{\text{CAS}}$	$\overline{\text{WE}}$	ODT	BA[2:0]	A[15:11]	A[10]	A[9:7]	A[6:3]	A[2:0]	Data ^{b)}		
toggling	Static High	0	0	ACT	0	0	1	1	0	0	00	0	0	0	0	-		
			1,2	D, D	1	0	0	0	0	0	0	00	0	0	0	0	-	
			3,4	$\overline{\text{D}}, \overline{\text{D}}$	1	1	1	1	0	0	0	00	0	0	0	0	-	
			...	repeat pattern 1...4 until nRAS - 1, truncate if necessary														
			nRAS	PRE	0	0	1	0	0	0	0	00	0	0	0	0	-	
			...	repeat pattern 1...4 until nRC - 1, truncate if necessary														
			1*nRC+0	ACT	0	0	1	1	0	00	00	0	0	F	0	-		
			...	repeat pattern 1...4 until 1*nRC + nRAS - 1, truncate if necessary														
			1*nRC+nRAS	PRE	0	0	1	0	0	0	0	00	0	0	F	0	-	
		...	repeat pattern 1...4 until 2*nRC - 1, truncate if necessary															
		1	2*nRC	repeat Sub-Loop 0, use BA[2:0] = 1 instead														
		2	4*nRC	repeat Sub-Loop 0, use BA[2:0] = 2 instead														
		3	6*nRC	repeat Sub-Loop 0, use BA[2:0] = 3 instead														
		4	8*nRC	repeat Sub-Loop 0, use BA[2:0] = 4 instead														
		5	10*nRC	repeat Sub-Loop 0, use BA[2:0] = 5 instead														
6	12*nRC	repeat Sub-Loop 0, use BA[2:0] = 6 instead																
7	14*nRC	repeat Sub-Loop 0, use BA[2:0] = 7 instead																

a) DM must be driven LOW all the time. DQS, $\overline{\text{DQS}}$ are FLOATING.
b) DQ signals are FLOATING.

Table 4 - IDD1 Measurement-Loop Pattern^{a)}

CK, CK	CKE	Sub-Loop	Cycle Number	Command	CS	RAS	CAS	WE	ODT	BA[2:0]	A[15:11]	A[10]	A[9:7]	A[6:3]	A[2:0]	Data ^{b)}		
toggling	Static High	0	0	ACT	0	0	1	1	0	0	00	0	0	0	0	-		
		1,2	D, D	1	0	0	0	0	0	0	00	0	0	0	0	0	-	
		3,4	\overline{D} , \overline{D}	1	1	1	1	1	0	0	00	0	0	0	0	0	0	-
		...	repeat pattern 1...4 until nRCD - 1, truncate if necessary															
		nRCD	RD	0	1	0	1	0	0	0	00	0	0	0	0	0	0000000 0	
		...	repeat pattern 1...4 until nRAS - 1, truncate if necessary															
		nRAS	PRE	0	0	1	0	0	0	0	00	0	0	0	0	0	-	
		...	repeat pattern 1...4 until nRC - 1, truncate if necessary															
		1*nRC+0	ACT	0	0	1	1	0	0	00	0	0	F	0	-			
		1*nRC+1,2	D, D	1	0	0	0	0	0	00	0	0	F	0	-			
		1*nRC+3,4	\overline{D} , \overline{D}	1	1	1	1	0	0	00	0	0	F	0	-			
		...	repeat pattern nRC + 1,...4 until nRC + nRCE - 1, truncate if necessary															
		1*nRC+nRCD	RD	0	1	0	1	0	0	00	0	0	F	0	0011001 1			
		...	repeat pattern nRC + 1,...4 until nRC + nRAS - 1, truncate if necessary															
		1*nRC+nRAS	PRE	0	0	1	0	0	0	00	0	0	F	0	-			
		...	repeat pattern nRC + 1,...4 until *2 nRC - 1, truncate if necessary															
		1	2*nRC	repeat Sub-Loop 0, use BA[2:0] = 1 instead														
		2	4*nRC	repeat Sub-Loop 0, use BA[2:0] = 2 instead														
		3	6*nRC	repeat Sub-Loop 0, use BA[2:0] = 3 instead														
		4	8*nRC	repeat Sub-Loop 0, use BA[2:0] = 4 instead														
5	10*nRC	repeat Sub-Loop 0, use BA[2:0] = 5 instead																
6	12*nRC	repeat Sub-Loop 0, use BA[2:0] = 6 instead																
7	14*nRC	repeat Sub-Loop 0, use BA[2:0] = 7 instead																

a) DM must be driven LOW all the time. DQS, \overline{DQS} are used according to RD Commands, otherwise FLOATING.

b) Burst Sequence driven on each DQ signal by Read Command. Outside burst operation, DQ signals are FLOATING.

Table 5 - IDD2N and IDD3N Measurement-Loop Pattern^{a)}

CK, $\overline{\text{CK}}$	CKE	Sub-Loop	Cycle Number	Command	$\overline{\text{CS}}$	$\overline{\text{RAS}}$	$\overline{\text{CAS}}$	$\overline{\text{WE}}$	ODT	BA[2:0]	A[15:11]	A[10]	A[9:7]	A[6:3]	A[2:0]	Data ^{b)}		
toggling	Static High	0	0	D	1	0	0	0	0	0	0	0	0	0	0	0	-	
			1	D	1	0	0	0	0	0	0	0	0	0	0	0	0	-
			2	$\overline{\text{D}}$	1	1	1	1	1	0	0	0	0	0	0	F	0	-
			3	$\overline{\text{D}}$	1	1	1	1	1	0	0	0	0	0	0	F	0	-
		1	4-7	repeat Sub-Loop 0, use BA[2:0] = 1 instead														
		2	8-11	repeat Sub-Loop 0, use BA[2:0] = 2 instead														
		3	12-15	repeat Sub-Loop 0, use BA[2:0] = 3 instead														
		4	16-19	repeat Sub-Loop 0, use BA[2:0] = 4 instead														
		5	20-23	repeat Sub-Loop 0, use BA[2:0] = 5 instead														
		6	24-17	repeat Sub-Loop 0, use BA[2:0] = 6 instead														
7	28-31	repeat Sub-Loop 0, use BA[2:0] = 7 instead																

- a) DM must be driven LOW all the time. DQS, $\overline{\text{DQS}}$ are FLOATING.
b) DQ signals are FLOATING.

Table 6 - IDD2NT and IDDQ2NT Measurement-Loop Pattern^{a)}

CK, $\overline{\text{CK}}$	CKE	Sub-Loop	Cycle Number	Command	$\overline{\text{CS}}$	$\overline{\text{RAS}}$	$\overline{\text{CAS}}$	$\overline{\text{WE}}$	ODT	BA[2:0]	A[15:11]	A[10]	A[9:7]	A[6:3]	A[2:0]	Data ^{b)}		
toggling	Static High	0	0	D	1	0	0	0	0	0	0	0	0	0	0	0	-	
			1	D	1	0	0	0	0	0	0	0	0	0	0	0	0	-
			2	$\overline{\text{D}}$	1	1	1	1	1	0	0	0	0	0	0	F	0	-
			3	$\overline{\text{D}}$	1	1	1	1	1	0	0	0	0	0	0	F	0	0000000 0
		1	4-7	repeat Sub-Loop 0, but ODT = 0 and BA[2:0] = 1														
		2	8-11	repeat Sub-Loop 0, but ODT = 1 and BA[2:0] = 2														
		3	12-15	repeat Sub-Loop 0, but ODT = 1 and BA[2:0] = 3														
		4	16-19	repeat Sub-Loop 0, but ODT = 0 and BA[2:0] = 4														
		5	20-23	repeat Sub-Loop 0, but ODT = 0 and BA[2:0] = 5														
		6	24-17	repeat Sub-Loop 0, but ODT = 1 and BA[2:0] = 6														
7	28-31	repeat Sub-Loop 0, but ODT = 1 and BA[2:0] = 7																

- a) DM must be driven LOW all the time. DQS, $\overline{\text{DQS}}$ are FLOATING.
b) DQ signals are FLOATING.

Table 7 - IDD4R and IDDQ24R Measurement-Loop Pattern^{a)}

CK, $\overline{\text{CK}}$	CKE	Sub-Loop	Cycle Number	Command	$\overline{\text{CS}}$	$\overline{\text{RAS}}$	$\overline{\text{CAS}}$	$\overline{\text{WE}}$	ODT	BA[2:0]	A[15:11]	A[10]	A[9:7]	A[6:3]	A[2:0]	Data ^{b)}		
toggling	Static High	0	0	RD	0	1	0	1	0	0	00	0	0	0	0	000000 00		
			1	D	1	0	0	0	0	0	0	00	0	0	0	0	-	
			2,3	$\overline{\text{D}}, \overline{\text{D}}$	1	1	1	1	1	0	0	00	0	0	0	0	0	-
			4	RD	0	1	0	1	0	0	0	00	0	0	F	0	001100 11	
			5	D	1	0	0	0	0	0	0	00	0	0	F	0	-	
			6,7	$\overline{\text{D}}, \overline{\text{D}}$	1	1	1	1	1	0	0	00	0	0	F	0	-	
			1	8-15	repeat Sub-Loop 0, but BA[2:0] = 1													
		2	16-23	repeat Sub-Loop 0, but BA[2:0] = 2														
		3	24-31	repeat Sub-Loop 0, but BA[2:0] = 3														
		4	32-39	repeat Sub-Loop 0, but BA[2:0] = 4														
		5	40-47	repeat Sub-Loop 0, but BA[2:0] = 5														
		6	48-55	repeat Sub-Loop 0, but BA[2:0] = 6														
		7	56-63	repeat Sub-Loop 0, but BA[2:0] = 7														

a) DM must be driven LOW all the time. DQS, $\overline{\text{DQS}}$ are used according to RD Commands, otherwise FLOATING.

b) Burst Sequence driven on each DQ signal by Read Command. Outside burst operation, DQ signals are FLOATING.

Table 8 - IDD4W Measurement-Loop Pattern^{a)}

CK, $\overline{\text{CK}}$	CKE	Sub-Loop	Cycle Number	Command	$\overline{\text{CS}}$	$\overline{\text{RAS}}$	$\overline{\text{CAS}}$	$\overline{\text{WE}}$	ODT	BA[2:0]	A[15:11]	A[10]	A[9:7]	A[6:3]	A[2:0]	Data ^{b)}	
toggling	Static High	0	0	WR	0	1	0	0	1	0	00	0	0	0	0	000000 00	
			1	D	1	0	0	0	1	0	00	0	0	0	0	-	
			2,3	$\overline{\text{D}}, \overline{\text{D}}$	1	1	1	1	1	1	0	00	0	0	0	0	-
			4	WR	0	1	0	0	0	1	0	00	0	0	F	0	001100 11
		5	D	1	0	0	0	0	1	0	00	0	0	F	0	-	
			6,7	$\overline{\text{D}}, \overline{\text{D}}$	1	1	1	1	1	1	0	00	0	0	F	0	-
			1	8-15	repeat Sub-Loop 0, but BA[2:0] = 1												
		2	16-23	repeat Sub-Loop 0, but BA[2:0] = 2													
		3	24-31	repeat Sub-Loop 0, but BA[2:0] = 3													
		4	32-39	repeat Sub-Loop 0, but BA[2:0] = 4													
		5	40-47	repeat Sub-Loop 0, but BA[2:0] = 5													
		6	48-55	repeat Sub-Loop 0, but BA[2:0] = 6													
		7	56-63	repeat Sub-Loop 0, but BA[2:0] = 7													

a) DM must be driven LOW all the time. DQS, $\overline{\text{DQS}}$ are used according to WR Commands, otherwise FLOATING.

b) Burst Sequence driven on each DQ signal by Write Command. Outside burst operation, DQ signals are FLOATING.

Table 9 - IDD5B Measurement-Loop Pattern^{a)}

CK, $\overline{\text{CK}}$	CKE	Sub-Loop	Cycle Number	Command	$\overline{\text{CS}}$	$\overline{\text{RAS}}$	$\overline{\text{CAS}}$	$\overline{\text{WE}}$	ODT	BA[2:0]	A[15:11]	A[10]	A[9:7]	A[6:3]	A[2:0]	Data ^{b)}		
toggling	Static High	0	0	REF	0	0	0	1	0	0	0	0	0	0	0	-		
		1	1.2	D, D	1	0	0	0	0	0	0	00	0	0	0	0	-	
			3,4	$\overline{\text{D}}$, $\overline{\text{D}}$	1	1	1	1	1	0	0	00	0	0	F	0	-	
			5...8	repeat cycles 1...4, but BA[2:0] = 1														
			9...12	repeat cycles 1...4, but BA[2:0] = 2														
			13...16	repeat cycles 1...4, but BA[2:0] = 3														
			17...20	repeat cycles 1...4, but BA[2:0] = 4														
			21...24	repeat cycles 1...4, but BA[2:0] = 5														
			25...28	repeat cycles 1...4, but BA[2:0] = 6														
			29...32	repeat cycles 1...4, but BA[2:0] = 7														
2	33...nRFC-1	repeat Sub-Loop 1, until nRFC - 1. Truncate, if necessary.																

a) DM must be driven LOW all the time. DQS, $\overline{\text{DQS}}$ are FLOATING.

b) DQ signals are FLOATING.

Table 10 - IDD7 Measurement-Loop Pattern^{a)}

ATTENTION! Sub-Loops 10-19 have inverse A[6:3] Pattern and Data Pattern than Sub-Loops 0-9

CK, CK	CKE	Sub-Loop	Cycle Number	Command	CS	RAS	CAS	WE	ODT	BA[2:0]	A[15:11]	A[10]	A[9:7]	A[6:3]	A[2:0]	Data ^{b)}		
toggling	Static High	0	0	ACT	0	0	1	1	0	0	00	0	0	0	0	-		
			1	RDA	0	1	0	1	0	0	0	00	1	0	0	0	00000000	
			2	D	1	0	0	0	0	0	0	0	00	0	0	0	0	-
		...	repeat above D Command until nRRD - 1															
		1	nRRD	ACT	0	0	1	1	0	1	00	0	0	F	0	0	-	
			nRRD+1	RDA	0	1	0	1	0	1	00	1	0	F	0	00110011		
			nRRD+2	D	1	0	0	0	0	1	00	0	0	F	0	-		
			...	repeat above D Command until 2* nRRD - 1														
		2	2*nRRD	repeat Sub-Loop 0, but BA[2:0] = 2														
		3	3*nRRD	repeat Sub-Loop 1, but BA[2:0] = 3														
		4	4*nRRD	D	1	0	0	0	0	3	00	0	0	F	0	-		
			...	Assert and repeat above D Command until nFAW - 1, if necessary														
		5	nFAW	repeat Sub-Loop 0, but BA[2:0] = 4														
		6	nFAW+nRRD	repeat Sub-Loop 1, but BA[2:0] = 5														
		7	nFAW+2*nRRD	repeat Sub-Loop 0, but BA[2:0] = 6														
		8	nFAW+3*nRRD	repeat Sub-Loop 1, but BA[2:0] = 7														
		9	nFAW+4*nRRD	D	1	0	0	0	0	7	00	0	0	F	0	-		
			...	Assert and repeat above D Command until 2* nFAW - 1, if necessary														
		10	2*nFAW+0	ACT	0	0	1	1	0	0	00	0	0	F	0	-		
			2*nFAW+1	RDA	0	1	0	1	0	0	00	1	0	F	0	00110011		
			2&nFAW+2	D	1	0	0	0	0	0	00	0	0	F	0	-		
		...	Repeat above D Command until 2* nFAW + nRRD - 1															
		11	2*nFAW+nRRD	ACT	0	0	1	1	0	1	00	0	0	0	0	-		
			2*nFAW+nRRD+1	RDA	0	1	0	1	0	1	00	1	0	0	0	00000000		
			2&nFAW+nRRD+2	D	1	0	0	0	0	1	00	0	0	0	0	-		
		...	Repeat above D Command until 2* nFAW + 2* nRRD - 1															
		12	2*nFAW+2*nRRD	repeat Sub-Loop 10, but BA[2:0] = 2														
		13	2*nFAW+3*nRRD	repeat Sub-Loop 11, but BA[2:0] = 3														
		14	2*nFAW+4*nRRD	D	1	0	0	0	0	0	00	0	0	0	0	-		
			...	Assert and repeat above D Command until 3* nFAW - 1, if necessary														
15	3*nFAW	repeat Sub-Loop 10, but BA[2:0] = 4																
16	3*nFAW+nRRD	repeat Sub-Loop 11, but BA[2:0] = 5																
17	3*nFAW+2*nRRD	repeat Sub-Loop 10, but BA[2:0] = 6																
18	3*nFAW+3*nRRD	repeat Sub-Loop 11, but BA[2:0] = 7																
14	3*nFAW+4*nRRD	D	1	0	0	0	0	0	00	0	0	0	0	-				
	...	Assert and repeat above D Command until 4* nFAW - 1, if necessary																

a) DM must be driven LOW all the time. DQS, \overline{DQS} are used according to RD Commands, otherwise FLOATING.

b) Burst Sequence driven on each DQ signal by Read Command. Outside burst operation, DQ signals are FLOATING.

6. Electrical Characteristics and AC Timing

6.1 Refresh Parameters by Device Density

Parameter	Symbol	512Mb	1Gb	2Gb	4Gb	8Gb	Units
REF command to ACT or REF command time	tRFC	90	110	160	300	350	ns
Average periodic refresh interval	tREFI	$0 \times C < T_{CASE} < 85 \times C$	7.8	7.8	7.8	7.8	us
		$85 \times C < T_{CASE} < 95 \times C$	3.9	3.9	3.9	3.9	us

6.2 DDR3 SDRAM Standard Speed Bins include tCK, tRCD, tRP, tRAS and tRC for each corresponding bin

DDR3 1066 Speed Bin		DDR3-1066F		Unit	Note	
CL - nRCD - nRP		7-7-7				
Parameter	Symbol	min	max			
Internal read command to first data	t_{AA}	13.125	20	ns		
ACT to internal read or write delay time	t_{RCD}	13.125	—	ns		
PRE command period	t_{RP}	13.125	—	ns		
ACT to ACT or REF command period	t_{RC}	50.625	—	ns		
ACT to PRE command period	t_{RAS}	37.5	9 * tREFI	ns		
CL = 5	CWL = 5	$t_{CK(AVG)}$	Reserved		ns	1)2)3)4)6)
	CWL = 6	$t_{CK(AVG)}$	Reserved		ns	4)
CL = 6	CWL = 5	$t_{CK(AVG)}$	2.5	3.3	ns	1)2)3)6)
	CWL = 6	$t_{CK(AVG)}$	Reserved		ns	1)2)3)4)
CL = 7	CWL = 5	$t_{CK(AVG)}$	Reserved		ns	4)
	CWL = 6	$t_{CK(AVG)}$	1.875	< 2.5	ns	1)2)3)4)
CL = 8	CWL = 5	$t_{CK(AVG)}$	Reserved		ns	4)
	CWL = 6	$t_{CK(AVG)}$	1.875	< 2.5	ns	1)2)3)
Supported CL Settings		6, 7, 8		n_{CK}		
Supported CWL Settings		5, 6		n_{CK}		

DDR3 1333 Speed Bin		DDR3-1333H		Unit	Note	
CL - nRCD - nRP		9-9-9				
Parameter	Symbol	min	max			
Internal read command to first data	t_{AA}	13.5	20	ns		
ACT to internal read or write delay time	t_{RCD}	13.5	—	ns		
PRE command period	t_{RP}	13.5	—	ns		
ACT to ACT or REF command period	t_{RC}	49.5	—	ns		
ACT to PRE command period	t_{RAS}	36	9 * tREFI	ns		
CL = 5	CWL = 5	$t_{CK(AVG)}$	Reserved		ns	1,2,3,4,7
	CWL = 6, 7	$t_{CK(AVG)}$	Reserved		ns	4
CL = 6	CWL = 5	$t_{CK(AVG)}$	2.5	3.3	ns	1,2,3,7
	CWL = 6	$t_{CK(AVG)}$	Reserved		ns	1,2,3,4,7
	CWL = 7	$t_{CK(AVG)}$	Reserved		ns	4
CL = 7	CWL = 5	$t_{CK(AVG)}$	Reserved		ns	4
	CWL = 6	$t_{CK(AVG)}$	1.875	< 2.5	ns	1,2,3,4,7
		(Optional) Note 9.10				
CL = 8	CWL = 5	$t_{CK(AVG)}$	Reserved		ns	4
	CWL = 6	$t_{CK(AVG)}$	1.875	< 2.5	ns	1,2,3,7
	CWL = 7	$t_{CK(AVG)}$	Reserved		ns	1,2,3,4
CL = 9	CWL = 5, 6	$t_{CK(AVG)}$	Reserved		ns	4
	CWL = 7	$t_{CK(AVG)}$	1.5	< 1.875	ns	1,2,3,4
CL = 10	CWL = 5, 6	$t_{CK(AVG)}$	Reserved		ns	4
	CWL = 7	$t_{CK(AVG)}$	1.5	< 1.875	ns	1,2,3
			(Optional)		ns	5
Supported CL Settings		6, 7, 8, 9		n_{CK}		
Supported CWL Settings		5, 6, 7		n_{CK}		

Speed Bin Table Notes

Absolute Specification (T_{OPER} ; $V_{DDQ} = V_{DD} = 1.5V \pm 0.075V$);

Notes:

1. The CL setting and CWL setting result in tCK(AVG).MIN and tCK(AVG).MAX requirements. When making a selection of tCK (AVG), both need to be fulfilled: Requirements from CL setting as well as requirements from CWL setting.
2. tCK(AVG).MIN limits: Since CAS Latency is not purely analog - data and strobe output are synchronized by the DLL - all possible intermediate frequencies may not be guaranteed. An application should use the next smaller JEDEC standard tCK (AVG) value (2.5, 1.875, 1.5, or 1.25 ns) when calculating CL [nCK] = tAA [ns] / tCK (AVG) [ns], rounding up to the next 'Supported CL'.
3. tCK(AVG).MAX limits: Calculate tCK (AVG) = tAA.MAX / CLSELECTED and round the resulting tCK (AVG) down to the next valid speed bin (i.e. 3.3ns or 2.5ns or 1.875 ns or 1.25 ns). This result is tCK(AVG).MAX corresponding to CLSELECTED.
4. 'Reserved' settings are not allowed. User must program a different value.
5. 'Optional' settings allow certain devices in the industry to support this setting, however, it is not a mandatory feature. Refer to supplier's data sheet and SPD information if and how this setting is supported.
6. Any DDR3-1066 speed bin also supports functional operation at lower frequencies as shown in the table which are not subject to Production Tests but verified by Design/Characterization.
7. Any DDR3-1333 speed bin also supports functional operation at lower frequencies as shown in the table which are not subject to Production Tests but verified by Design/Characterization.
8. It is not a mandatory bin. Refer to supplier's data sheet and/or the DIMM SPD information.
9. If it's supported, the minimum tAA/tRCD/tRP that this device support is 13.125ns. Therefore, In Module application, tAA/tRCD/tRP should be programed with minimum supported values. For example, DDR3-1333H supporting down-shift to DDR3-1066F should program SPD as 13.125ns for tAAmin(Byte16)/tRCDmin(Byte18)/tRP(Byte20). DDR3-1600K supporting down-shift to DDR3-1333H and/or DDR3-1066F should program SPD as 13.125ns for tAAmin(Byte16)/tRCDmin(Byte18)/tRP(Byte20).

7. DIMM Outline Diagram

7.1 64Mx64 - HMT164S6BFR6C

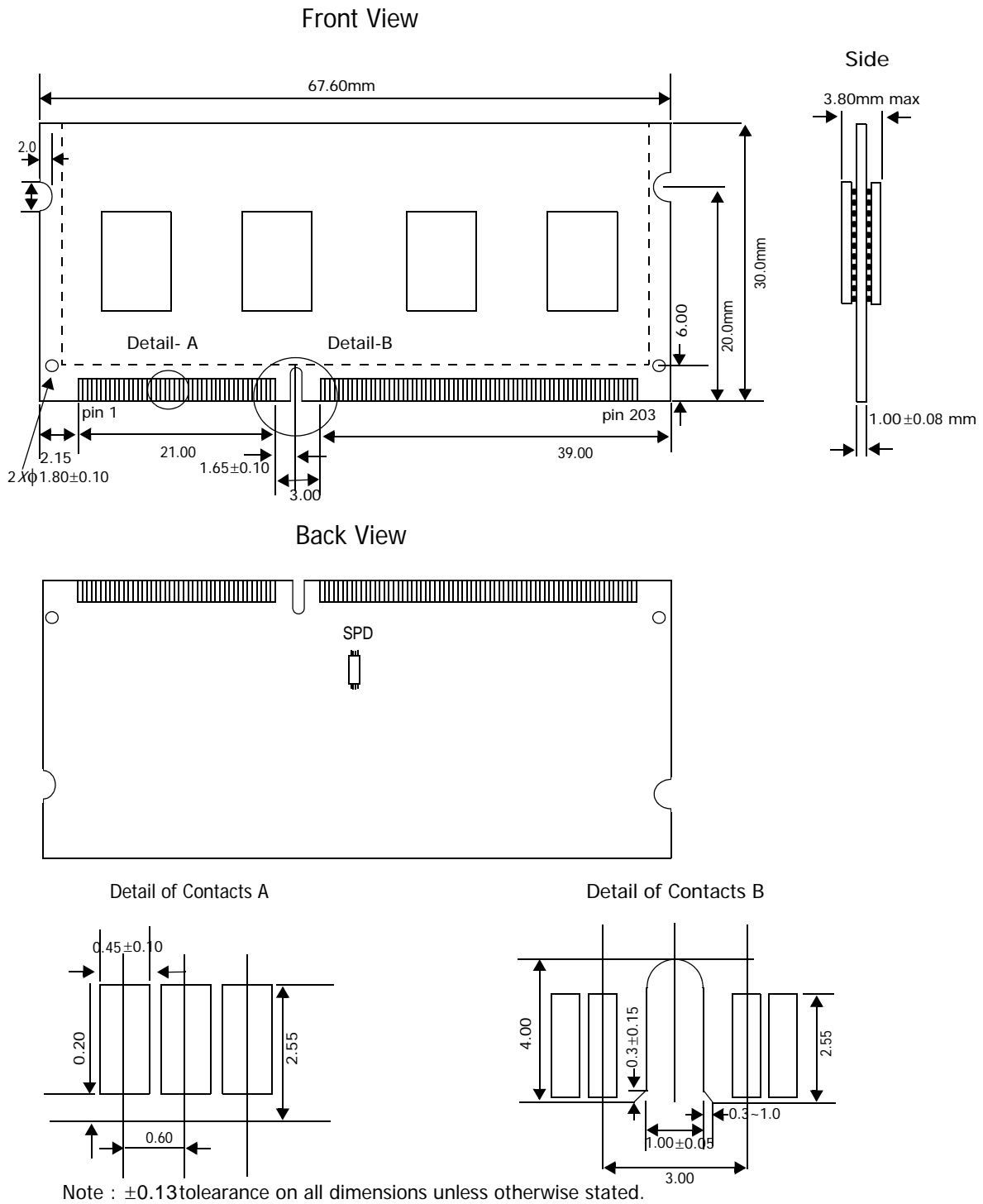

64Mx64 - HMT164S6BFR6C (with temperature sensor)

Front View

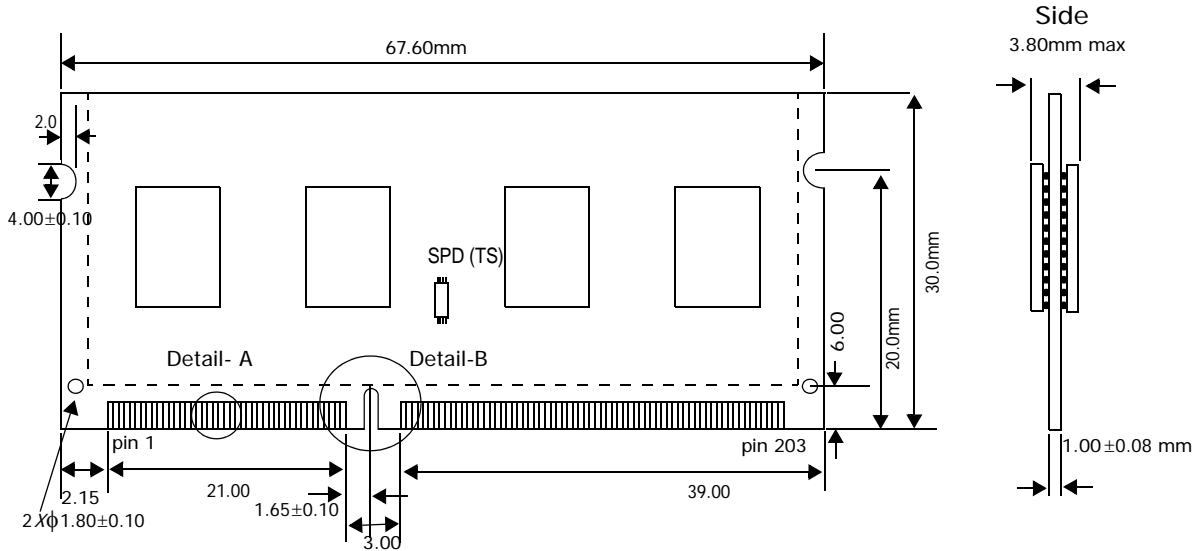

Back View

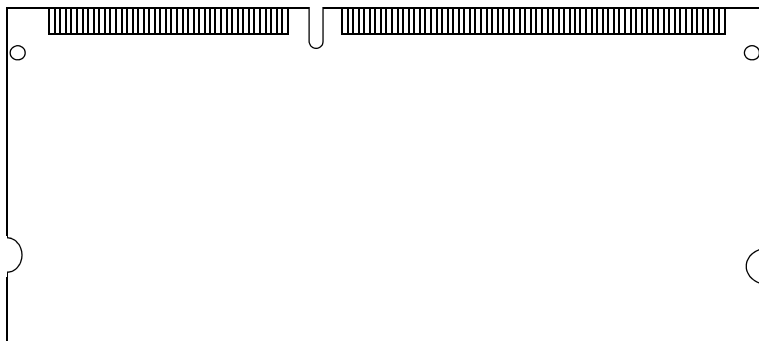

Detail of Contacts A

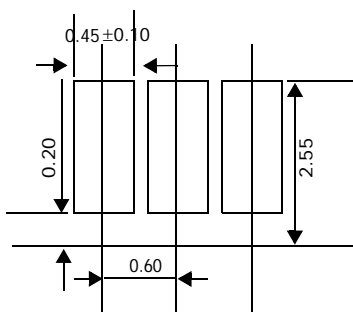

Detail of Contacts B

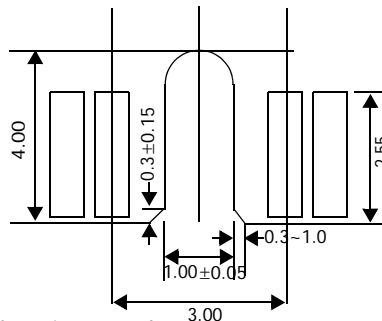

Note : ±0.13tolerance on all dimensions unless otherwise stated.

7.2 128Mx64 - HMT112S6BFR6C

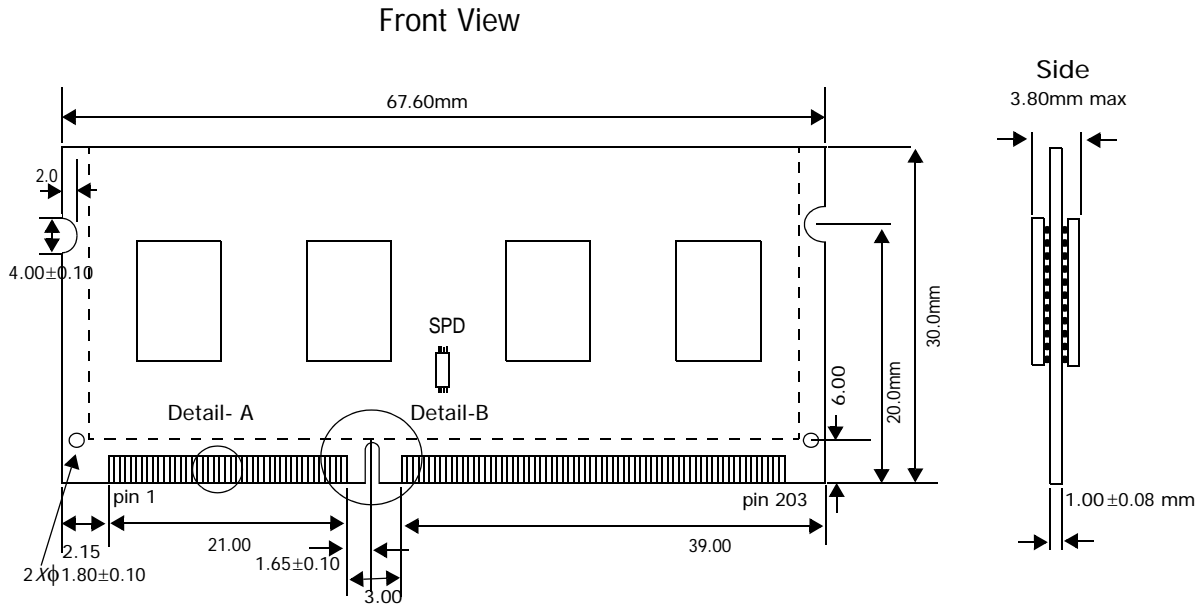

Back View

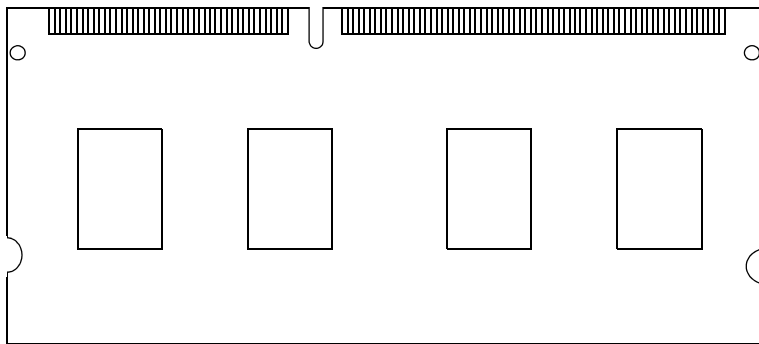

Detail of Contacts A

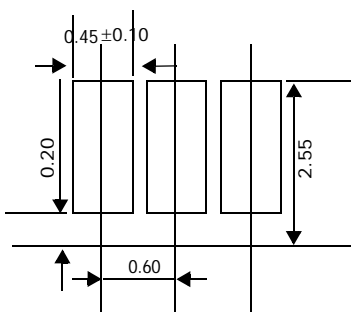

Detail of Contacts B

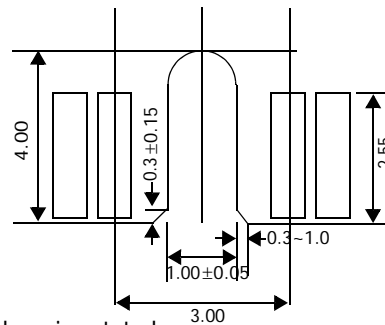

Note : ±0.13tolerance on all dimensions unless otherwise stated.

128Mx64 - HMT112S6BFR6C (with temperature sensor)

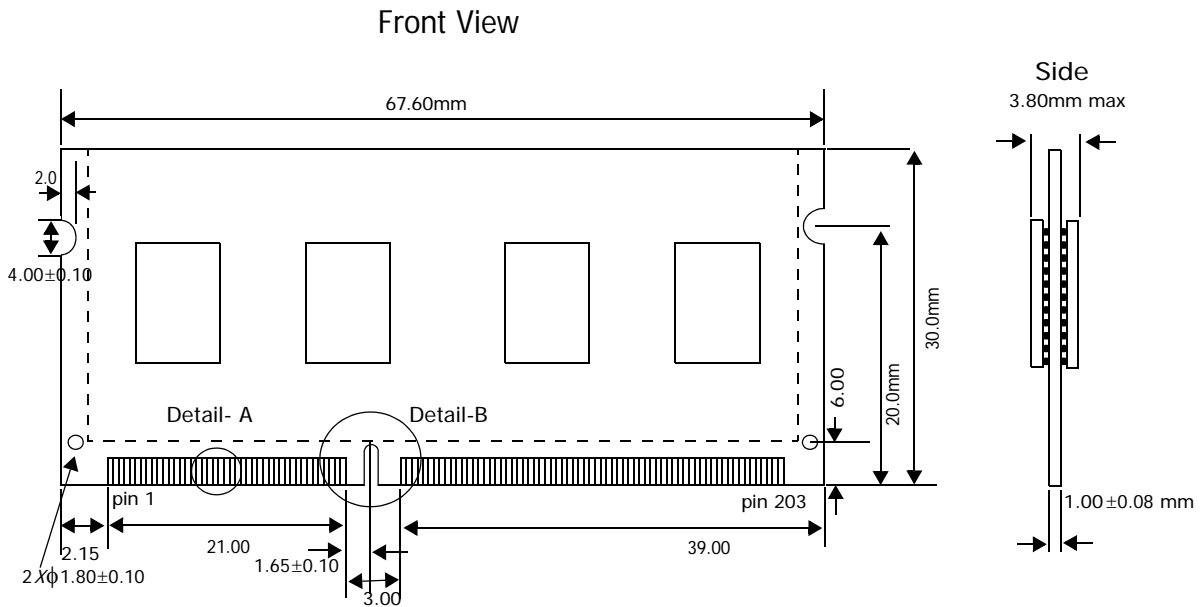

Back View

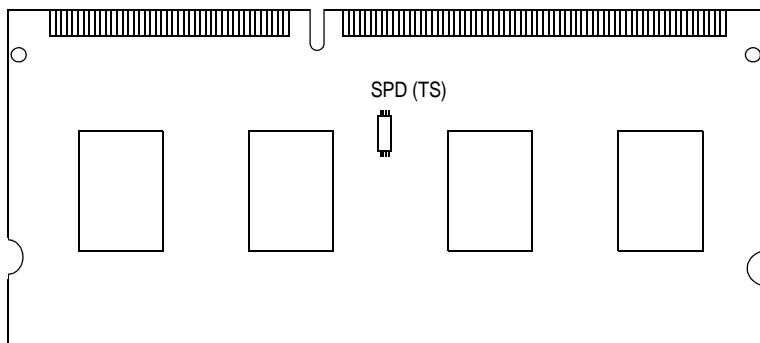

Detail of Contacts A

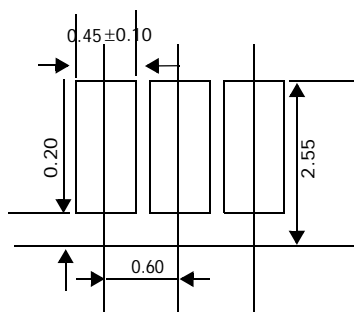

Detail of Contacts B

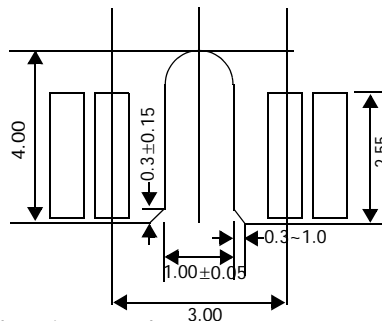

Note : ±0.13tolerance on all dimensions unless otherwise stated.

7.3 256Mx64 - HMT125S6BFR8C

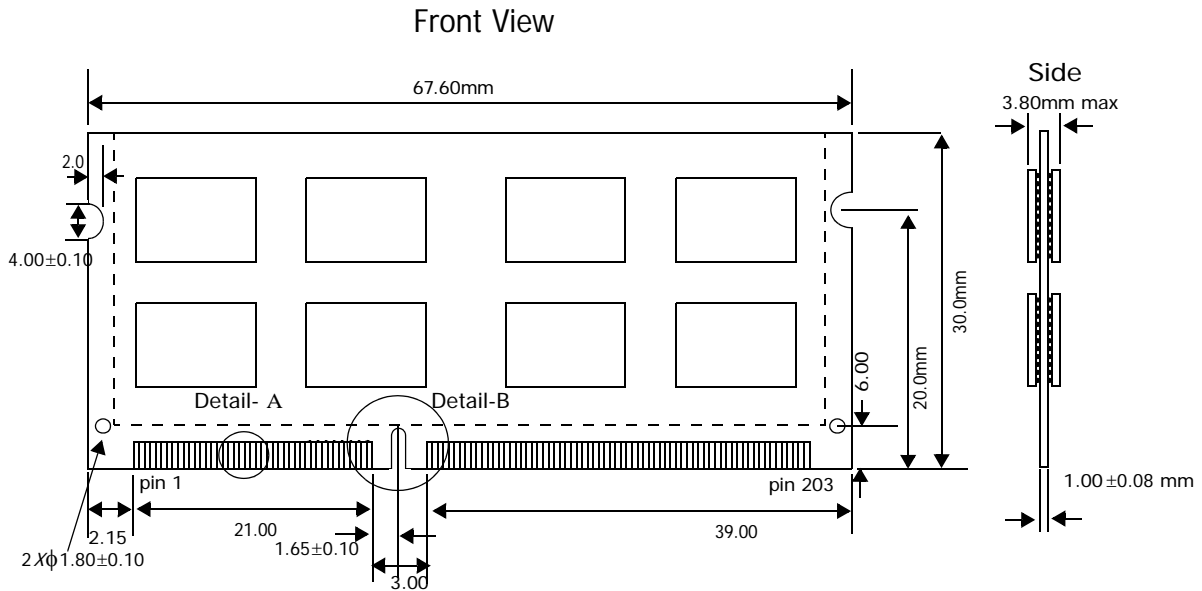

Back View

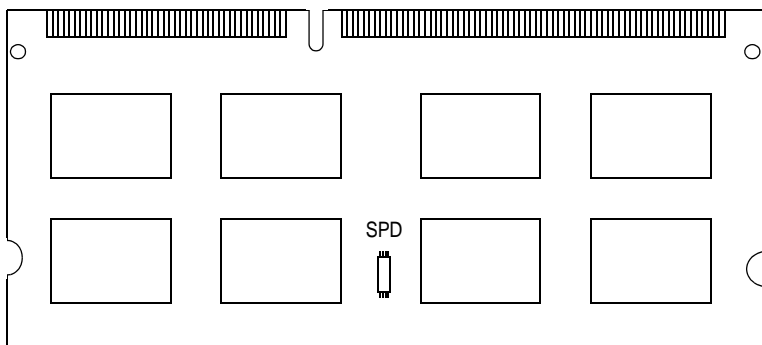

Detail of Contacts A

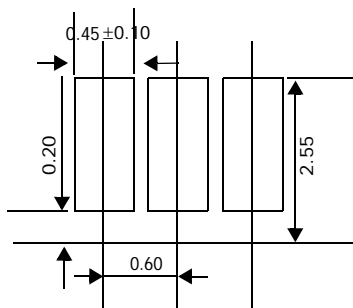

Detail of Contacts B

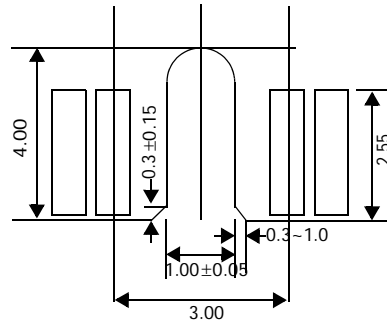

Note : ±0.13tolerance on all dimensions unless otherwise stated.

256Mx64 - HMT125S6BFR8C (with temperature sensor)

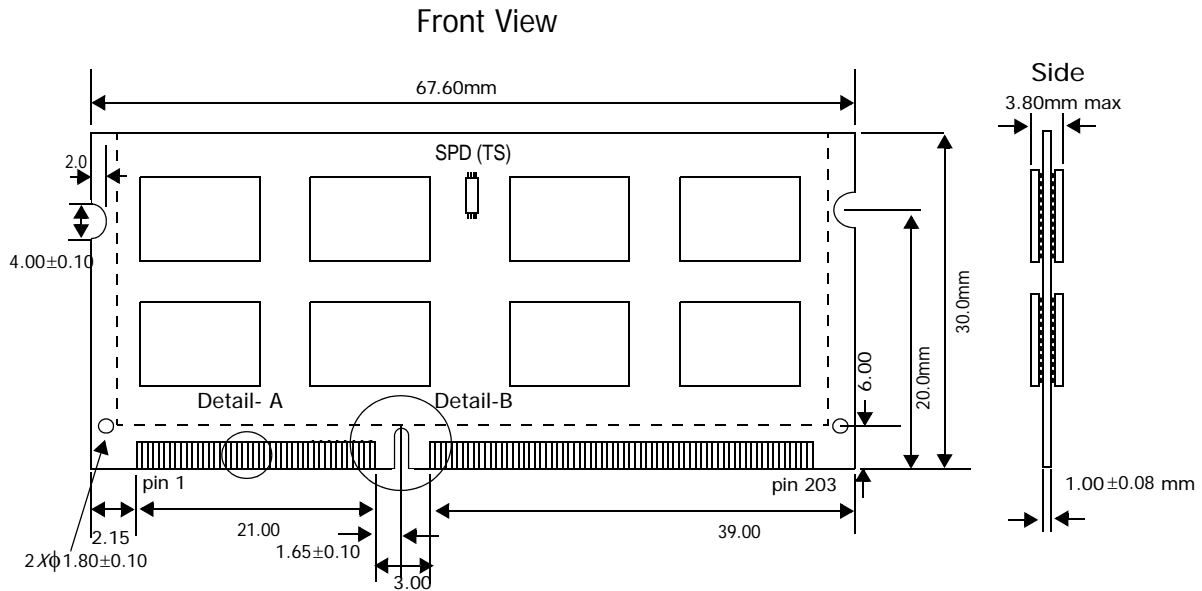

Back View

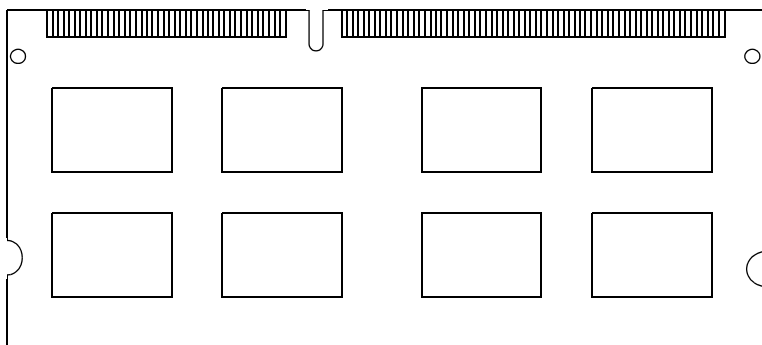

Detail of Contacts A

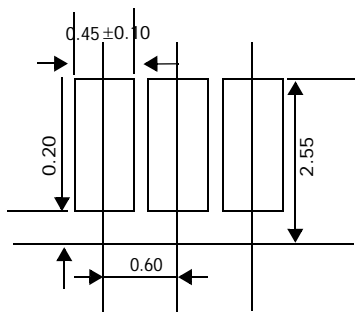

Detail of Contacts B

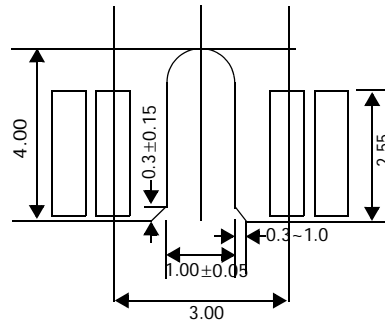

Note : ±0.13tolerance on all dimensions unless otherwise stated.