

1. Mechanical Dimensions:

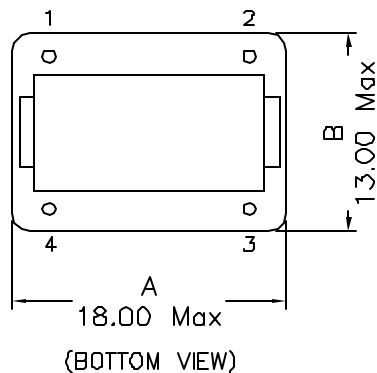
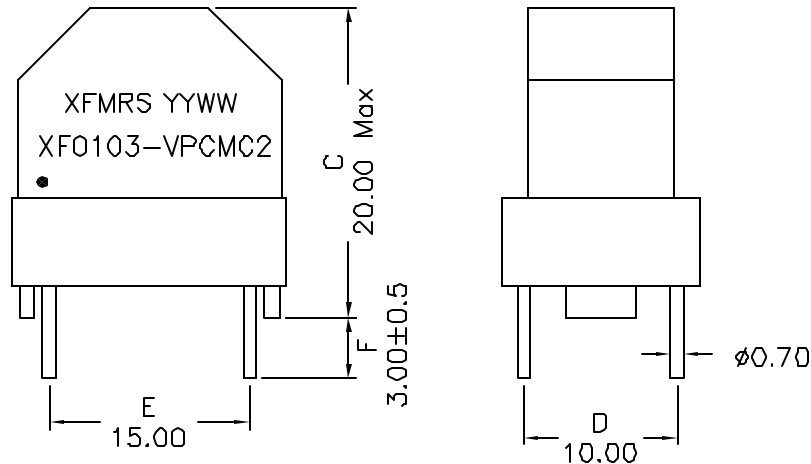

Notes:

1. Solderability: Leads shall meet MIL-STD-202, Method 208D for solderability.
2. Flammability: UL94V-0
3. ASTM oxygen index: > 28%
4. Insulation System: Class F 155°C. UL file E151556
5. Operating Temperature Range: All listed parameters are to be within tolerance from -40°C to +85°C
6. Storage Temperature Range: -55°C to +125°C
7. Aqueous wash compatible
8. SMD Lead Coplanarity: ±0.004" (0.102mm)
9. Moisture Sensitivity: Level 3
10. Electrical and mechanical specifications 100% tested
11. RoHS Compliant Component

DOC REV: A/1

2. Schematic:

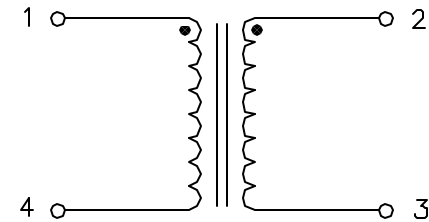

3. Electrical Specifications:

OCL: 10.0mH±30% @10KHz 0.1V, Each Wdg

LL: 90.0uH Typ @10KHz 0.1V

DCR: 0.600 Ohms Typ, Each Wdg

Irated: 0.7Arms

Isolation: 1500Vac, Wdg to Wdg, 2Sec

Rated Voltage: 250Vac

XFMR5 Inc www.XFMR5.com	Title: Common Mode Choke		
	UNLESS OTHERWISE SPECIFIED TOLERANCES:	P/N: XF0103-VPCMC2	REV. A
.xx ±0.25	DWN.	Kang Chen	Dec-13-04
Dimensions in MM	CHK.	YK Liao	Dec-13-04
SHEET 1 OF 1	APP.	J Ng	Dec-13-04