

MARS-3100R

10.4" Fully Rugged Industrial Tablet PC



Features

- Rugged design protects system from shock/vibration damage
- IP54-rated, fully-sealed chassis for water/dust resistance
- Powerful communication capabilities with optional built-in WLAN, Bluetooth and GSM/GPRS/EDGE modules
- Supports Windows® XP for easy development
- Wide -10 to 55° C operation for extreme environments

Introduction

The Advantech MARS-3100R series is a 10.4" Industrial Tablet PC for applications such as manufacturing, warehousing, factory maintenance, field service, transportation, and police, fire, or other emergency services. The rugged design of the MARS-3100R resists shock and vibration to safeguard data while on the move. The whole MARS-3100 chassis is fully sealed per IP54 ratings to prevent water and dust damage in outdoor applications. In addition, the optional built-in WLAN, Bluetooth and GSM/GPRS/EDGE modules facilitate data transfer and communications.

Powerful System

The MARS-3100R uses an Intel® Core™ Duo ULV U2500 1.2 GHz processor, making it the most powerful model of the MARS-3100 series. This enables the MARS-3100R to run demanding applications like live 3D CAD/CAE demonstrations and other professional programs.

Fully Rugged Design

The wide -10 to 55° C operating temperature, sunlight readable screen, and adjustable brightness features of the MARS-3100R make it a fully-ruggedized tablet PC that tolerates extreme environments while showing a clear picture.

Wireless Communication

For people on the move, the MARS-3100R provides optional built-in GSM/GPRS/EDGE WAN, 802.11a/b/g LAN and Bluetooth PAN connectivity for complete wireless communication capabilities. All options come with a built-in internal antenna, so users can easily access remote databases or exchange information with others no matter where they are.

Specifications

Processor System	Processor	Intel Core Duo Ultra Low Voltage U2500 @ 1.2 GHz	
	Chipset	Intel 945GME	
	Graphics	Intel 945GME with 64-224 MB shared memory	
	Memory	- 1GB DDR2 memory module in one 200-pin SODIMM slot	
	Storage	- Removable 2.5" 40 GB shock mounted HDD - Optional CF slot for storage	
	OS	Windows XP	
Display	Panel	- 10.4" XGA TFT LCD	
		- Optional Sunlight Readable solution - 8-level brightness	
Communication	Wireless	Wireless LAN 802.11a/b/g (Default) (only Band1 and Band4)	
	WAN	GSM/GPRS/EDGE (Optional)	
	Bluetooth	Bluetooth V2.0/EDR (Default)	
User Control Interface		Dual panel input, Digitizer and resistive touchscreen 5-way navigation key 3 x application hotkeys (programmable) SAS button	Screen rotation key Power button WLAN ON/OFF button
I/O Interface	RS-232	1 x 9-pin D-sub RS-232	
	USB	2 x USB 2.0	
	LAN	1 x 10/100 Mbps, RJ-45	
	VGA out	1 x 15-pin D-sub VGA	
	Audio	1 x Microphone jack 1 x Headset jack	
Power	Adapter	Auto-switching 100 ~ 240 V, 50 ~ 60 Hz supplying 19 V _{DC} @ 3.16 A	
	Battery	Warm-swappable 11.1 V @ 3600 mAh Li-ion battery pack	
	Battery Life	2.5 ~ 3.5 hours	
	Charging Time	2.5 hours to 90%	
Mechanical	Dimensions	299 x 224 x 37 mm (11.77" x 8.82" x 1.46")	
	Weight	2.1 kg (4.63 lb)	

Dimensions

Unit: mm

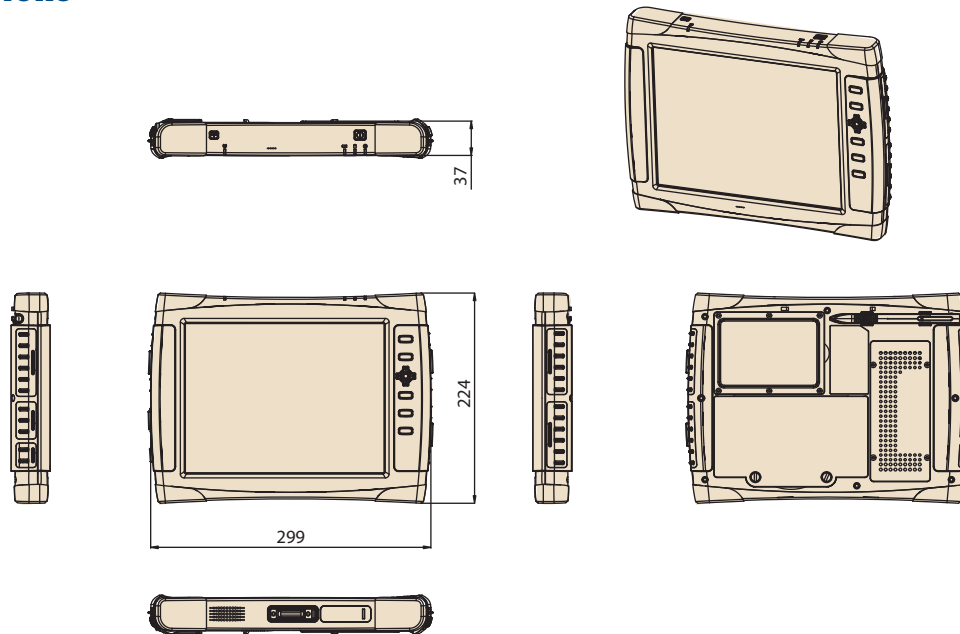

Specifications

Environment	Operating Humidity	0% ~ 95% non-condensing MIL-STD810F Method 507.4	
	Storage Humidity	0% ~ 95% non-condensing MIL-STD810F Method 507.4	
	Operating Temperature	-10 ~ 55° C MIL-STD 810F Methods 501.4 and 502.4 Procedure II Cold boot (battery mode): 0° C @ 50% charge (0 ~ 40° C for battery charging) Cold boot (adapler mode): Any	
	Storage Temperature	-40 ~ 60° C MIL-STD 810F Methods 501.4 and 502.4 Procedure I	
	Water/Dust Resistance	IP54 equivalent	
	Drop	3 ft free drop to steel during operation. MIL-STD-810F, Method 516.5 Procedure IV	
	Vibration	Operation: MIL-STD 810F Methods 514.5C-1 for HDD and MIL-STD 810F Methods 514.5C-3 for CF Non-Operation: 0.04g ² /Hz, 20Hz - 1000Hz, -6dB/octave 1000Hz-2000Hz, MIL-STD-810F method 514.5C-17	
	Mechanical Shock	Operating: 20g, 11ms, Terminal sawtooth Non-operating: 40g, 11ms, Terminal sawtooth, MIL-STD-810F method 516.5	
Certifications and Standards	Low Pressure	15,000 ft. In accordance with MIL-STD810F method 500.4 Procedure I	
	Certifications	- FCC, CE, UL/cUL, CCC	
	EMC	-EN55022 Class B -EN55011 Class A	-FCC Part15 Class B -DOC Class B
	EMS	- Contact: 4Kv/Air: 8Kv, EN55024	
	Safety	- UL/cUL, UL60950-1 - CB, IEC/EN60950-1	
	RF	- CE-R&TTE EN301489-1/-17 and EN 300328 - CE SAR test EN50385 - CE CAB report	- CE 28 country notify - FCC Part 15c and 15e - FCC SAR test OET 65.C

Ordering Information

Part No.	Description
MARS-3100R-175300E	MARS-3100R basic model, 40 GB HDD 1 GB DDR2, 802.11 a/b/g, BT, with XP Pro (OEM)
MARS-3100R-175800E	MARS-3100R basic model, 40 GB HDD 1 GB DDR2, 802.11 a/b/g, BT, GPRS, with XP Pro (OEM)
MARS-3100R-175312E	MARS-3100R basic model, 40 GB HDD 1 GB DDR2, 802.11 a/b/g, BT, Fingerprint scanner, 1.3M AF CMOS, with XP Pro (OEM)
MARS-3100R-A75300E	MARS-3100R with Sunlight-readable solution, 40 GB HDD, 1GB DDR2, 802.11 a/b/g, BT, with XP Pro (OEM)