

Features

- 4 PIN diodes in a SOT-25 Plastic Package
- Externally Selectable Bias and RF Matching Network
- Lead-Free (RoHS Compliant) Equivalents Available with 260 °C Reflow Compatibility
- 5 – 3,000 MHz Useable Frequency Band
- + 45 dBm IIP3 @ 1 GHz (50 Ω)
- 2.8 dB Loss @ 1 GHz (50 Ω)
- 36 dB Attenuation @ 1 GHz (50 Ω)

Description and Applications

M/A-COM's MA4P290-1225T & MADP-007167-12250T RoHs equivalent product is a wideband, moderate insertion loss, high IP3, PIN Diode π Quad Attenuator in a low-cost, surface mount SOT-25 package. Four PIN Diodes in one package reduce circuit parasitics and improve circuit density.

These PIN Diode Attenuators perform well where Variable RF Amplitude Control is required in 50 and 75 Ω circuit applications.

Wideband Attenuation Range, Frequency Flatness, and Input IP3 make these devices suitable for better power level control in RF Amplifiers.

Absolute Maximum Ratings @ 25 °C ¹

Parameter	Absolute Maximum
Operating Temperature	-65 °C to +125 °C
Storage Temperature (0 mW Dissipated Power)	-65 °C to +150 °C
Junction Temperature	+175 °C
DC Voltage at Temperature Extremes	-200 V
DC Current per diode	200 mA
Mounting Temperature	+235 °C for 10 seconds

1. Exceeding these limits may cause permanent damage.

Package Outline (Topview)

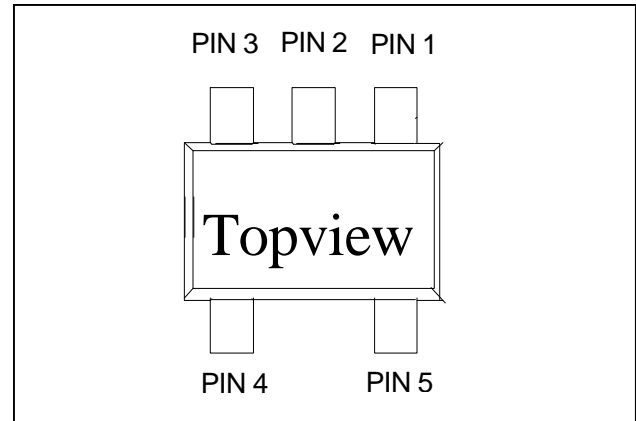

PIN Configuration ²

PIN	Function	PIN	Function
1	RF INPUT	4	Shunt 1 Bias
2	Series Bias	5	Shunt 2 Bias
3	RF OUTPUT		

2. RF INPUT and RF OUTPUT are Functionally Symmetrical

Standard Part	RoHs Equivalent Part
MA4P290-1225T	MADP-007167-12250T

Electrical Specifications @ 25 °C

Parameter	Condition	Unit	Typical	Max.
Reverse Current (I_R)	$V_r = 200\text{ V}$	μA		10
Capacitance (C_T)	$F = 1\text{ MHz}, V = 50\text{ V}$	pF	.20	.30
Resistance (R_S)	$F = 100\text{ MHz}, I = 1\text{ mA}$	Ω	85	
Resistance (R_S)	$F = 100\text{ MHz}, I = 10\text{ mA}$	Ω	11	16
Resistance (R_S)	$F = 100\text{ MHz}, I = 100\text{ mA}$	Ω	3	
Minority Carrier Lifetime (T_L)	$IF = 10\text{ mA}$	μS	2.7	
I Region Width		μm	175	

Typical 50 Ω SOT-25 RF Performance @ +25 °C using Wide Band RF Circuit Design (Values Shown include Through Loss Calibrated Out of RF Test Circuit)

Parameter	Frequency Range	Test Conditions	Units	Min.	Typ.	Max.
Insertion Loss	50 – 3,000 MHz	13 mA / Series Diode and 3.7 V Shunt 1 and 2 Bias $F = 1\text{ GHz}$	dB		-2.8	
Return Loss	50 – 3,000 MHz	13 mA / Series Diode and 3.7 V Shunt 1 and 2 Bias $F = 1\text{ GHz}$	dB		-15	
Attenuation	50 – 3,000 MHz	0 mA / Series Diode and 3.7 V Shunt 1 and 2 Bias $F = 1\text{ GHz}$	dB		-36	
Input IP3	50 – 3,000 MHz	0 V / Series Diode and 3.7 V Shunt 1 and 2 Bias $F1 = 1010\text{ MHz}, F2 = 1020\text{ MHz}$	dBm		45	
Input IP3	50 – 3,000 MHz	+ 10 V / Series Diode and 3.7 V Shunt 1 and 2 Bias $F1 = 1010\text{ MHz}, F2 = 1020\text{ MHz}$	dBm		43.5	
Input IP3	50 – 3,000 MHz	0 V / Series Diode and 3.7 V Shunt 1 and 2 Bias $F1 = 110\text{ MHz}, F2 = 120\text{ MHz}$	dBm		43.5	
Input IP3	50 – 3,000 MHz	+ 10 V / Series Diode and 3.7 V Shunt 1 and 2 Bias $F1 = 110\text{ MHz}, F2 = 120\text{ MHz}$	dBm		39	
Settling Time	50 – 3,000 MHz	Within 1 dB of Final Attenuation Value $F = 1\text{ GHz}$	μS		10	
RF C.W. Incident Power	50 – 3,000 MHz	0 – 20 V Series Diode Bias and 3.7V Shunt 1 and 2 Bias	dBm		+ 20	

Typical Diode Performance Curves

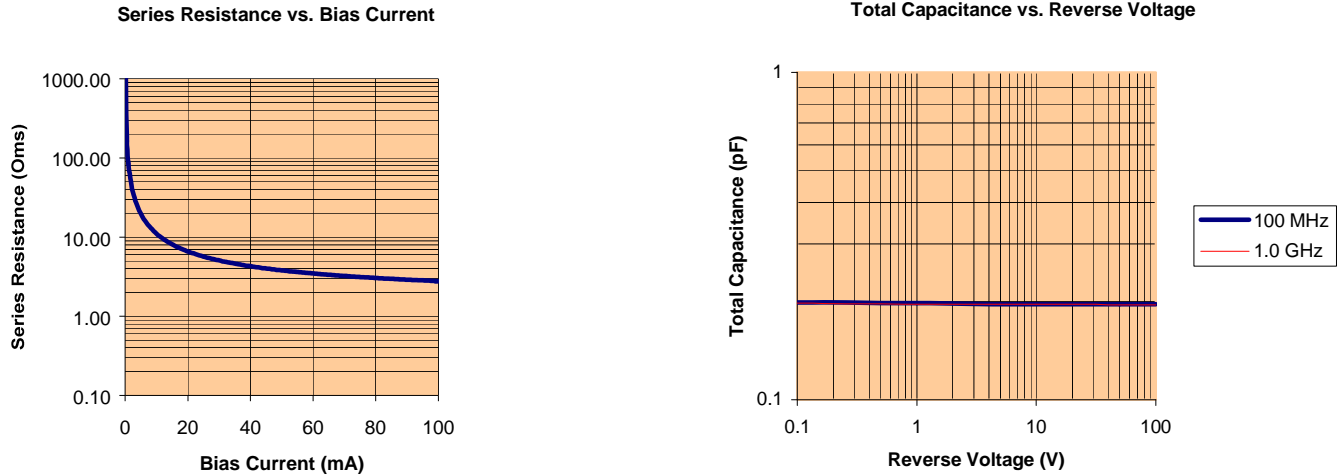

Typical Attenuator Performance

INPUT IP3 vs VOLTAGE

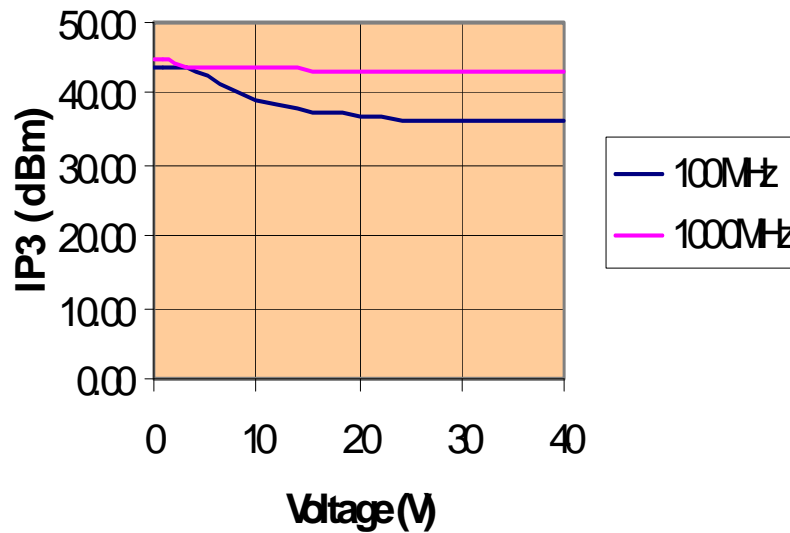

Typical Attenuator Performance

ATTENUATION vs. FREQUENCY

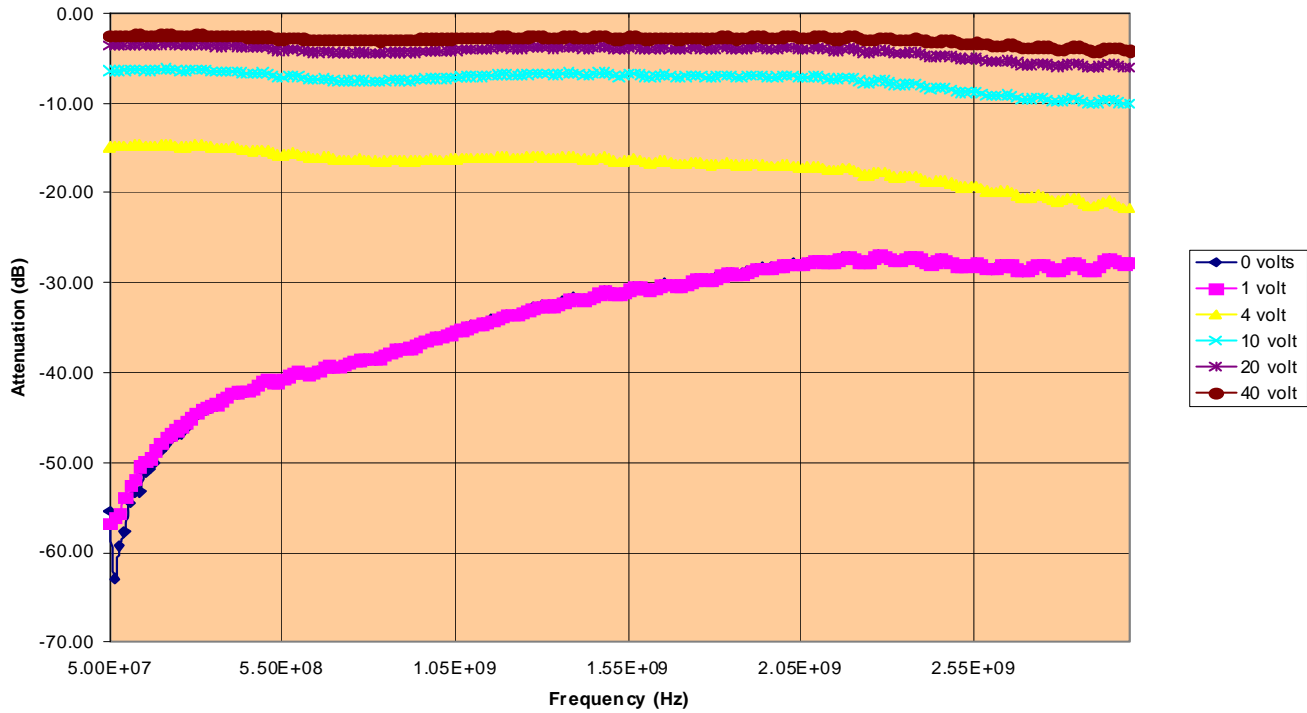

ATTENUATION FLATNESS vs. FREQUENCY

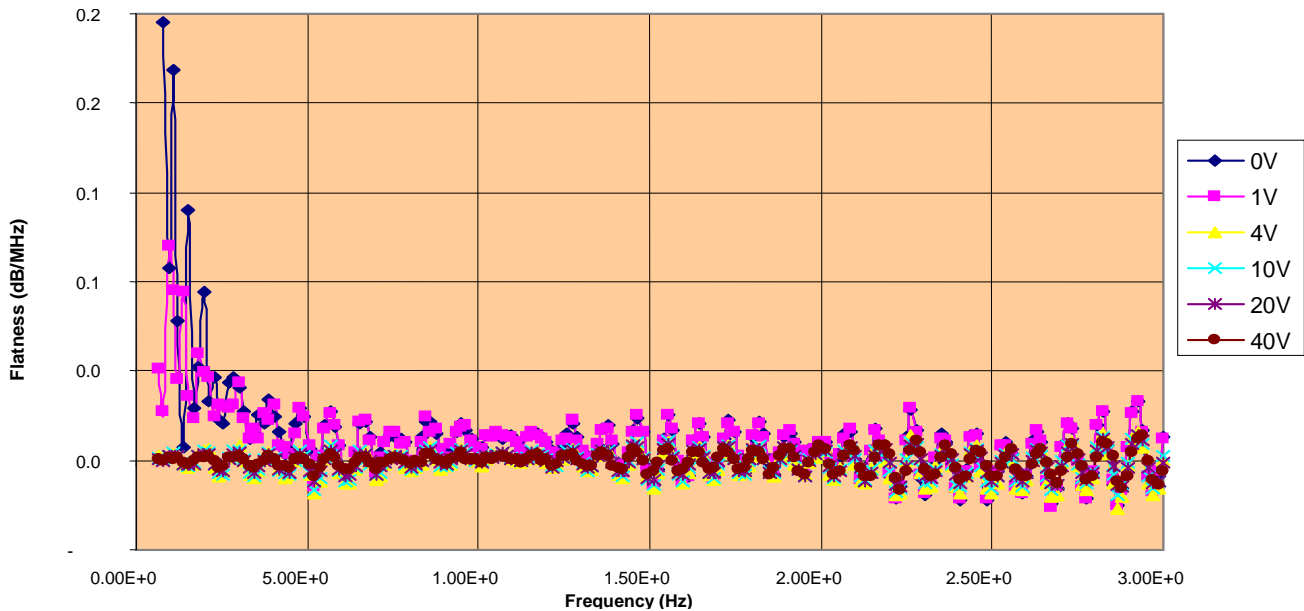

ADVANCED: Data Sheets contain information regarding a product M/A-COM Technology Solutions is considering for development. Performance is based on target specifications, simulated results, and/or prototype measurements. Commitment to develop is not guaranteed.
PRELIMINARY: Data Sheets contain information regarding a product M/A-COM Technology Solutions has under development. Performance is based on engineering tests. Specifications are typical. Mechanical outline has been fixed. Engineering samples and/or test data may be available. Commitment to produce in volume is not guaranteed.

• **North America** Tel: 800.366.2266 / Fax: 978.366.2266
 • **Europe** Tel: 44.1908.574.200 / Fax: 44.1908.574.300
 • **Asia/Pacific** Tel: 81.44.844.8296 / Fax: 81.44.844.8298
 Visit www.macomtech.com for additional data sheets and product information.

M/A-COM Technology Solutions Inc. and its affiliates reserve the right to make changes to the product(s) or information contained herein without notice.

RETURN LOSS vs. FREQUENCY

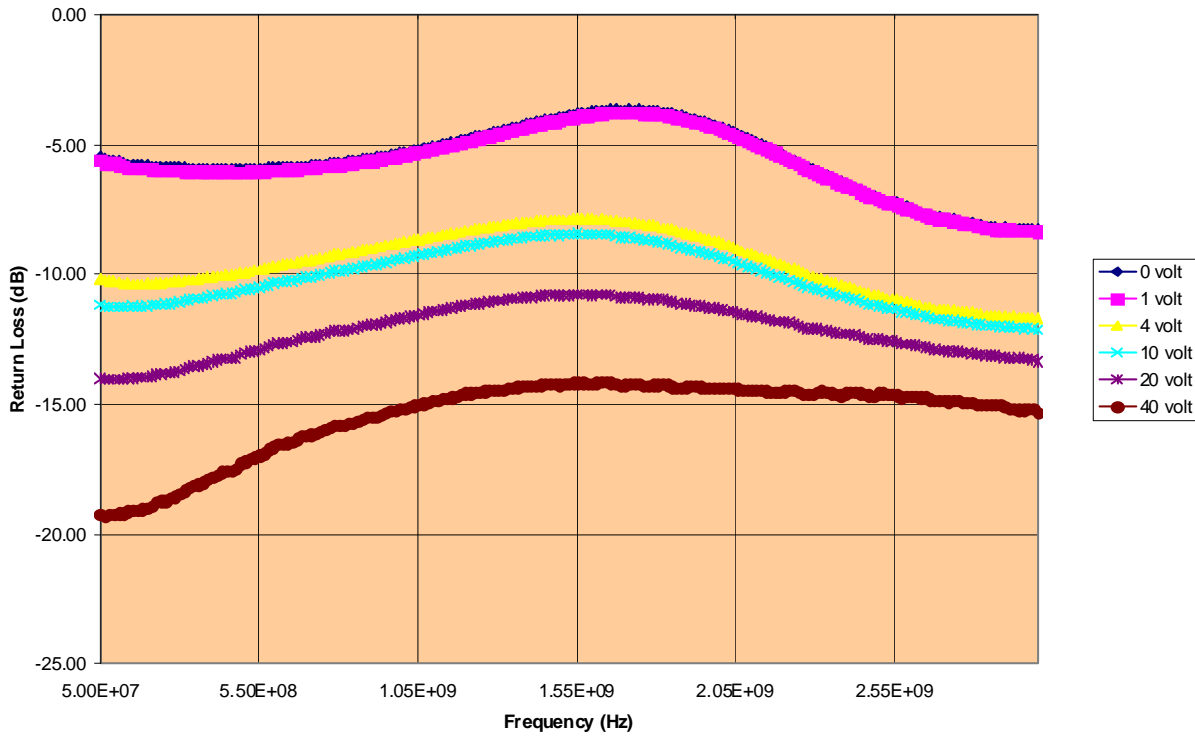

Functional Schematic

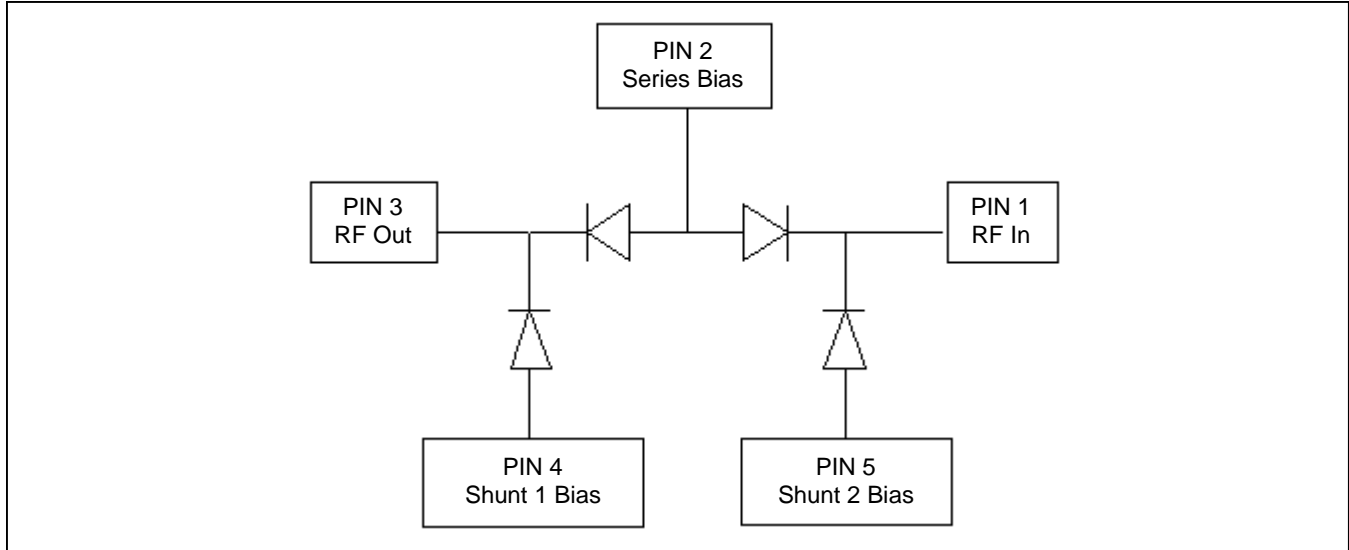

SOT-25 Case Style 1225

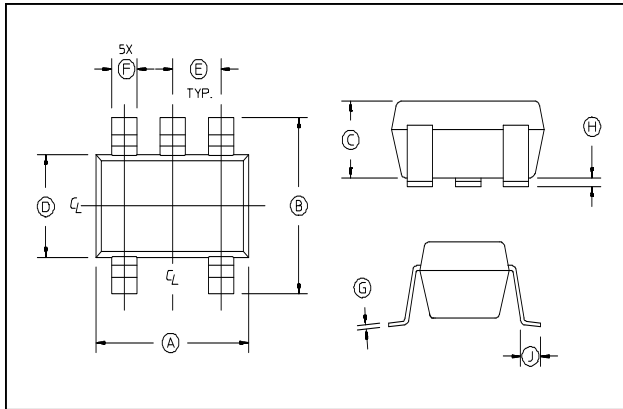

Dim	Inches		Millimeters	
	Min.	Max.	Min.	Max.
A	.1103	.1181	2.80	3.10
B	.1023	.1181	2.6	3.00
C	0.0355	.0512	0.9	1.30
D	0.0591	.0669	1.5	1.70
E	.0374 REF.		0.95 REF.	
F	.0138	.0197	.35	.50
G	.0031	0.0079	.08	0.2
H	.0002	.0059	.05	.15
J	.0138	.0216	.35	.55