

KOI-6002ASH

Features

- Small footprint surface mount package(1.8 H x 2.90 W x 7.40 L)
- Operating Voltage(Vcc) from 2.7 V to 5.5 V
- Operating Temperature from -20 °C to 85 °C
- LED Stuck High Protection
- Complete Shut-down at TxD, RxD, PIN diode

Applications

- Cellular Phones(both CDMA & GSM based)
- PDAs, PDA Phones, Smart Phones
- POS Terminals(ex. IrFM dongles)
- Tablet, Notebook, Desktop PCs
- Portable Printers(for photos of Camera Phones), Inkjet & Laser Printers
- Digital Cameras
- KIOSKs, Vending Machines, ATMs

Dimensions

(Unit : mm)

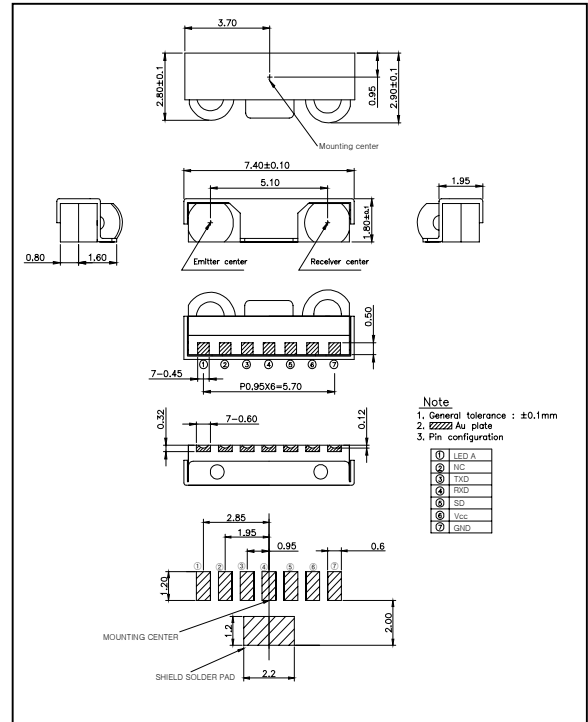

Block Diagram

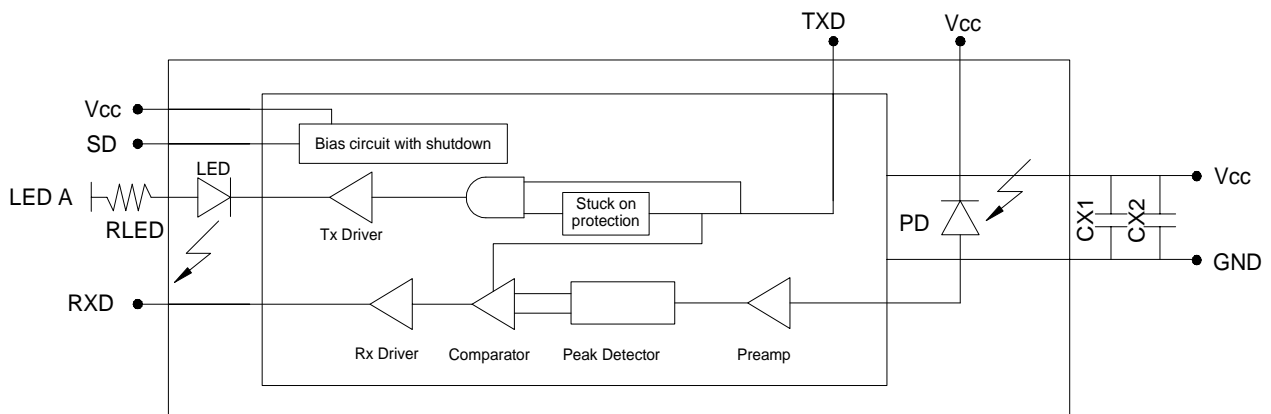

RLED 6.8Ω±5%, 0.25 Watt, LED A=2.7V
 RLED 10Ω±5%, 0.25 Watt, LED A=3.0V
 RLED 12Ω±5%, 0.25 Watt, LED A=3.6V
 RLED 16Ω±5%, 0.25 Watt, LED A=4.2V
 CX1 0.47μF±20%, Ceramic : CX2 4.7μF±20%, Tantalum
 CX1, CX2 must be placed 7mm of the KOI-6002ASH

KOI-6002ASH

Absolute Maximum Ratings

[Ta = 25 °C]

Parameter	Symbol	Conditions	Min.	Max.	Unit
Supply Voltage	V _{CC}	-	0	6.5	V
LED Supply Voltage	V _{LED}	-	0	6.0	V
Operating Temperature	T _{opr.}	-	-20	85	°C
Storage Temperature	T _{stg.}	-	-40	100	°C
DC LED Transmit Current	I _{LED (DC)}	-	-	50	mA
Peak LED Transmit Current	I _{LED (PK)}	<90µs pulse width, <20% duty cycle	-	200	mA
Peak LED Transmit Current	I _{LED (PK)}	Refer to Fig 1		450	mA
Receiver Data Output Voltage	V _{RxD}	-	-0.5	V _{CC} +0.5	V
Transmitter Data Input Voltage	V _{TxD}	-	-0.5	V _{CC} +0.5	V

Electro-Optical Characteristics

[Ta=25 °C , V_{CC}=3.3V]

Parameter	Symbol	Conditions	Min.	Typ.	Max.	Unit	
Supply Current	I _{cc1}	Shutdown	-	-	1	µA	
	I _{cc2}	Idle	-	100	200	µA	
	Active Receiver	V _{CC} =3.3V, TXD=GND	-	1	1.5	mA	
	Active Transmitter	V _{CC} =3.3V	-	13.5	15	mA	
Transmitter	Transmitter Wakeup Time	T _{tw}	-	30	200	µs	
	Viewing Angle	2θ _{1/2}	30	-	60	deg.	
	Data Output Pulse Width	T _{stp} w	tpw(RxD)=1.63µs at 115.2kbit/s	1.6	1.7	1.9	µs
	Rise Time	t _r	tpw(TxD)=1.63µs at 115.2kbit/s	-	20	600	ns
	Fall Time	t _f		-	20	600	ns
	Peak Emission Wavelength	λ _p	-	-	875	-	nm
	Spectral Bandwidth	Δλ	-	-	45	-	nm
Receiver	Viewing Angle	2θ _{1/2}	30	-	60.0	deg.	
	Peak Sensitivity Wavelength	λ _p	-	880	-	nm	
	High Level Output Voltage	V _{OH}	I _{OH} =-20µA	V _{CC} -0.2	-	-	V
	Low Level Output Voltage	V _{OL}	I _{OL} =1mA	-	-	0.4	V
	Rx SIR Pulse Width	T _{srp} w	tpw(TxD)=1.63µs at 115.2kbit/s	1	2.2	4	µs
	Rise Time	t _r	BR=115.2kbit/s	-	80	600	ns
	Fall Time	t _f		-	40	600	ns
	Communication Distance	D		0.6	1.0	-	m
	Receiver Latency Time	TL		-	100	150	µs
	Receiver Wakeup Time	T _{rw}		-	150	200	µs