

# HN58X2502I

# HN58X2504I

Serial Peripheral Interface

2k EEPROM (256-word × 8-bit)

4k EEPROM (512-word × 8-bit)

Electrically Erasable and Programmable Read Only Memory

REJ03C0061-0200

Rev.2.00

Jul.05.2005

---

## Description

HN58X25xxx Series is the Serial Peripheral Interface compatible (SPI) EEPROM (Electrically Erasable and Programmable ROM). It realizes high speed, low power consumption and a high level of reliability by employing advanced MONOS memory technology and CMOS process and low voltage circuitry technology. It also has a 16-byte page programming function to make it's write operation faster.

Note: Renesas Technology's serial EEPROM are authorized for using consumer applications such as cellular phones, camcorders, audio equipments. Therefore, please contact Renesas Technology's sales office before using industrial applications such as automotive systems, embedded controllers, and meters.

## Features

- Single supply: 1.8 V to 5.5 V
- Serial Peripheral Interface compatible (SPI bus)
  - SPI mode 0 (0,0), 3 (1,1)
- Clock frequency: 5 MHz (2.5 V to 5.5 V), 3 MHz (1.8 V to 5.5 V)
- Power dissipation:
  - Standby: 3  $\mu$ A (max)
  - Active (Read): 2 mA (max)
  - Active (Write): 2.5 mA (max)
- Automatic page write: 16-byte/page
- Write cycle time: 5 ms (2.5 V min), 8 ms (1.8 V min)
- Endurance: 10<sup>6</sup> Erase/Write Cycles
- Data retention: 10 Years
- Small size packages: SOP-8pin, TSSOP-8pin
- Shipping tape and reel
  - TSSOP-8pin: 3,000 IC/reel
  - SOP-8pin : 2,500 IC/reel
- Temperature range: -40 to +85 °C
- Lead free product.

### Ordering Information

Type No.	Internal organization	Operating voltage	Frequency	Package
HN58X2502FPIE	2-kbit (256 × 8-bit)	1.8 V to 5.5 V	5 MHz (2.5 V to 5.5 V)	150mil 8-pin plastic SOP PRSP0008DF-B (FP-8DBV) Lead free
HN58X2504FPIE	4-kbit (512 × 8-bit)		3 MHz (1.8 V to 5.5V)	
HN58X2502TIE	2-kbit (256 × 8-bit)	1.8 V to 5.5 V	5 MHz (2.5 V to 5.5 V)	8-pin plastic TSSOP PTSP0008JC-B (TTP-8DAV) Lead free
HN58X2504TIE	4-kbit (512 × 8-bit)		3 MHz (1.8 V to 5.5 V)	

### Pin Arrangement

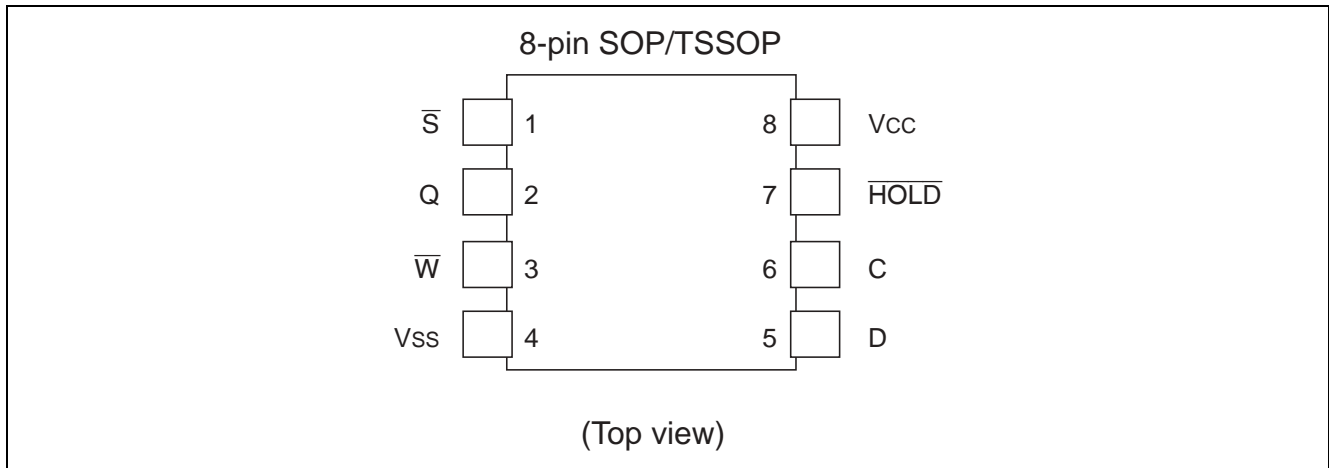

### Pin Description

Pin name	Function
C	Serial clock
D	Serial data input
Q	Serial data output
$\bar{S}$	Chip select
$\bar{W}$	Write protect
$\bar{HOLD}$	Hold
V <sub>CC</sub>	Supply voltage
V <sub>SS</sub>	Ground

## Block Diagram

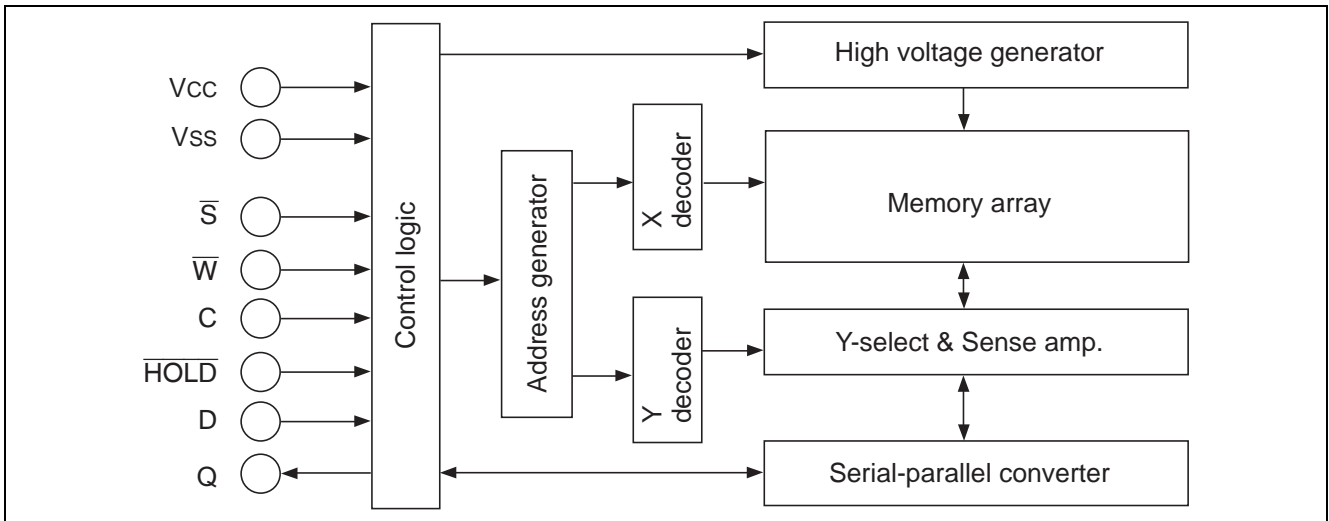

## Absolute Maximum Ratings

Parameter	Symbol	Value	Unit
Supply voltage relative to $V_{SS}$	$V_{CC}$	-0.6 to +7.0	V
Input voltage relative to $V_{SS}$	$V_{IN}$	-0.5* <sup>2</sup> to +7.0* <sup>3</sup>	V
Operating temperature range* <sup>1</sup>	$T_{opr}$	-40 to +85	°C
Storage temperature range	$T_{stg}$	-65 to +125	°C

Notes: 1. Including electrical characteristics and data retention.

2.  $V_{IN}$  (min): -3.0 V for pulse width  $\leq$  50 ns.

3. Should not exceed  $V_{CC} + 1.0$  V.

## DC Operating Conditions

Parameter	Symbol	Min	Typ	Max	Unit
Supply voltage	$V_{CC}$	1.8	—	5.5	V
	$V_{SS}$	0	0	0	V
Input voltage	$V_{IH}$	$V_{CC} \times 0.7$	—	$V_{CC} + 0.5$ * <sup>2</sup>	V
	$V_{IL}$	-0.3* <sup>1</sup>	—	$V_{CC} \times 0.3$	V
Operating temperature range	$T_{opr}$	-40	—	+85	°C

Notes: 1.  $V_{IN}$  (min): -1.0 V for pulse width  $\leq$  50 ns.

2.  $V_{IN}$  (max):  $V_{CC} + 1.0$  V for pulse width  $\leq$  50 ns.

## DC Characteristics

Parameter		Symbol	Min	Max	Unit	Test conditions
Input leakage current		$I_{LI}$	—	2	$\mu\text{A}$	$V_{CC} = 5.5\text{ V}$ , $V_{IN} = 0$ to $5.5\text{ V}$ ( $\bar{S}$ , D, C, HOLD, W)
Output leakage current		$I_{LO}$	—	2	$\mu\text{A}$	$V_{CC} = 5.5\text{ V}$ , $V_{OUT} = 0$ to $5.5\text{ V}$ (Q)
$V_{CC}$ current	Standby	$I_{SB}$	—	3	$\mu\text{A}$	$V_{IN} = V_{SS}$ or $V_{CC}$ , $V_{CC} = 5.5\text{ V}$
	Active	$I_{CC1}$	—	2	$\text{mA}$	$V_{CC} = 5.5\text{ V}$ , Read at $5\text{ MHz}$ $V_{IN} = V_{CC} \times 0.1/V_{CC} \times 0.9$ Q = OPEN
		$I_{CC2}$	—	2.5	$\text{mA}$	$V_{CC} = 5.5\text{ V}$ , Write at $5\text{ MHz}$ $V_{IN} = V_{CC} \times 0.1/V_{CC} \times 0.9$
Output voltage		$V_{OL1}$	—	0.4	V	$V_{CC} = 5.5\text{ V}$ , $I_{OL} = 2\text{ mA}$
		$V_{OL2}$	—	0.4	V	$V_{CC} = 2.5\text{ V}$ , $I_{OL} = 1.5\text{ mA}$
		$V_{OH1}$	$V_{CC} \times 0.8$	—	V	$V_{CC} = 5.5\text{ V}$ , $I_{OL} = -2\text{ mA}$
		$V_{OH2}$	$V_{CC} \times 0.8$	—	V	$V_{CC} = 2.5\text{ V}$ , $I_{OL} = -0.4\text{ mA}$

## AC Characteristics

### Test Conditions

- Input pules levels:
  - $V_{IL} = V_{CC} \times 0.2$
  - $V_{IH} = V_{CC} \times 0.8$
- Input rise and fall time:  $\leq 10$  ns
- Input and output timing reference levels:  $V_{CC} \times 0.3, V_{CC} \times 0.7$
- Output reference levels:  $V_{CC} \times 0.5$
- Output load: 100 pF

( $T_a = -40$  to  $+85^\circ\text{C}$ ,  $V_{CC} = 2.5$  V to 5.5 V)

Parameter	Symbol	Alt	Min	Max	Unit	Notes
Clock frequency	$f_C$	$f_{SCK}$	—	5	MHz	
$\overline{S}$ active setup time	$t_{SLCH}$	$t_{CSS1}$	90	—	ns	
$\overline{S}$ not active setup time	$t_{SHCH}$	$t_{CSS2}$	90	—	ns	
$\overline{S}$ deselect time	$t_{SHSL}$	$t_{CS}$	90	—	ns	
$\overline{S}$ active hold time	$t_{CHSH}$	$t_{CSH}$	90	—	ns	
$\overline{S}$ not active hold time	$t_{CHSL}$	—	90	—	ns	
Clock high time	$t_{CH}$	$t_{CLH}$	90	—	ns	1
Clock low time	$t_{CL}$	$t_{CLL}$	90	—	ns	1
Clock rise time	$t_{CLCH}$	$t_{RC}$	—	1	$\mu\text{s}$	2
Clock fall time	$t_{CHCL}$	$t_{FC}$	—	1	$\mu\text{s}$	2
Data in setup time	$t_{DVCH}$	$t_{DSU}$	20	—	ns	
Data in hold time	$t_{CHDX}$	$t_{DH}$	30	—	ns	
Clock low hold time after $\overline{HOLD}$ not active	$t_{HHCH}$	—	70	—	ns	
Clock low hold time after $\overline{HOLD}$ active	$t_{HLCH}$	—	40	—	ns	
Clock high setup time before $\overline{HOLD}$ active	$t_{CHHL}$	—	60	—	ns	
Clock high setup time before $\overline{HOLD}$ not active	$t_{CHHH}$	—	60	—	ns	
Output disable time	$t_{SHQZ}$	$t_{DIS}$	—	100	ns	2
Clock low to output valid	$t_{CLQV}$	$t_V$	—	70	ns	
Output hold time	$t_{CLQX}$	$t_{HO}$	0	—	ns	
Output rise time	$t_{QLQH}$	$t_{RO}$	—	50	ns	2
Output fall time	$t_{QHQL}$	$t_{FO}$	—	50	ns	2
$\overline{HOLD}$ high to output low-Z	$t_{HHQX}$	$t_{LZ}$	—	50	ns	2
$\overline{HOLD}$ low to output high-Z	$t_{HLQZ}$	$t_{HZ}$	—	100	ns	2
Write time	$t_W$	$t_{WC}$	—	5	ms	
Erase / Write Endurance	—	—	$10^6$	—	cycles	3

- Notes:
1.  $t_{CH} + t_{CL} \geq 1/f_C$
  2. Value guaranteed by characterization, not 100% tested in production.
  3. Value guaranteed by characterization, not 100% tested in products ( $T_a = 25^\circ\text{C}$ ).

(Ta = -40 to +85°C, V<sub>CC</sub> = 1.8 V to 5.5 V)

Parameter	Symbol	Alt	Min	Max	Unit	Notes
Clock frequency	f <sub>C</sub>	f <sub>SCK</sub>	—	3	MHz	
$\overline{S}$ active setup time	t <sub>SLCH</sub>	t <sub>CSS1</sub>	100	—	ns	
$\overline{S}$ not active setup time	t <sub>SHCH</sub>	t <sub>CSS2</sub>	100	—	ns	
$\overline{S}$ deselect time	t <sub>SHSL</sub>	t <sub>CS</sub>	150	—	ns	
$\overline{S}$ active hold time	t <sub>CHSH</sub>	t <sub>CSH</sub>	100	—	ns	
$\overline{S}$ not active hold time	t <sub>CHSL</sub>	—	100	—	ns	
Clock high time	t <sub>CH</sub>	t <sub>CLH</sub>	150	—	ns	1
Clock low time	t <sub>CL</sub>	t <sub>CLL</sub>	150	—	ns	1
Clock rise time	t <sub>CLCH</sub>	t <sub>RC</sub>	—	1	μs	2
Clock fall time	t <sub>CHCL</sub>	t <sub>FC</sub>	—	1	μs	2
Data in setup time	t <sub>DVCH</sub>	t <sub>DSU</sub>	30	—	ns	
Data in hold time	t <sub>CHDX</sub>	t <sub>DH</sub>	50	—	ns	
Clock low hold time after $\overline{HOLD}$ not active	t <sub>HHCH</sub>	—	140	—	ns	
Clock low hold time after $\overline{HOLD}$ active	t <sub>HLCH</sub>	—	90	—	ns	
Clock high setup time before $\overline{HOLD}$ active	t <sub>CHHL</sub>	—	120	—	ns	
Clock high setup time before $\overline{HOLD}$ not active	t <sub>CHHH</sub>	—	120	—	ns	
Output disable time	t <sub>SHQZ</sub>	t <sub>DIS</sub>	—	200	ns	2
Clock low to output valid	t <sub>CLQV</sub>	t <sub>V</sub>	—	120	ns	
Output hold time	t <sub>CLQX</sub>	t <sub>HO</sub>	0	—	ns	
Output rise time	t <sub>QLQH</sub>	t <sub>RO</sub>	—	100	ns	2
Output fall time	t <sub>QHQL</sub>	t <sub>FO</sub>	—	100	ns	2
$\overline{HOLD}$ high to output low-Z	t <sub>HHQX</sub>	t <sub>LZ</sub>	—	100	ns	2
$\overline{HOLD}$ low to output high-Z	t <sub>HLQZ</sub>	t <sub>HZ</sub>	—	100	ns	2
Write time	t <sub>W</sub>	t <sub>WC</sub>	—	8	ms	
Erase / Write Endurance	—	—	10 <sup>6</sup>	—	cycles	3

Notes: 1. t<sub>CH</sub> + t<sub>CL</sub> ≥ 1/f<sub>C</sub>

2. Value guaranteed by characterization, not 100% tested in production.

3. Value guaranteed by characterization, not 100% tested in products (Ta = 25°C).

## Timing Waveforms

### Serial Input Timing

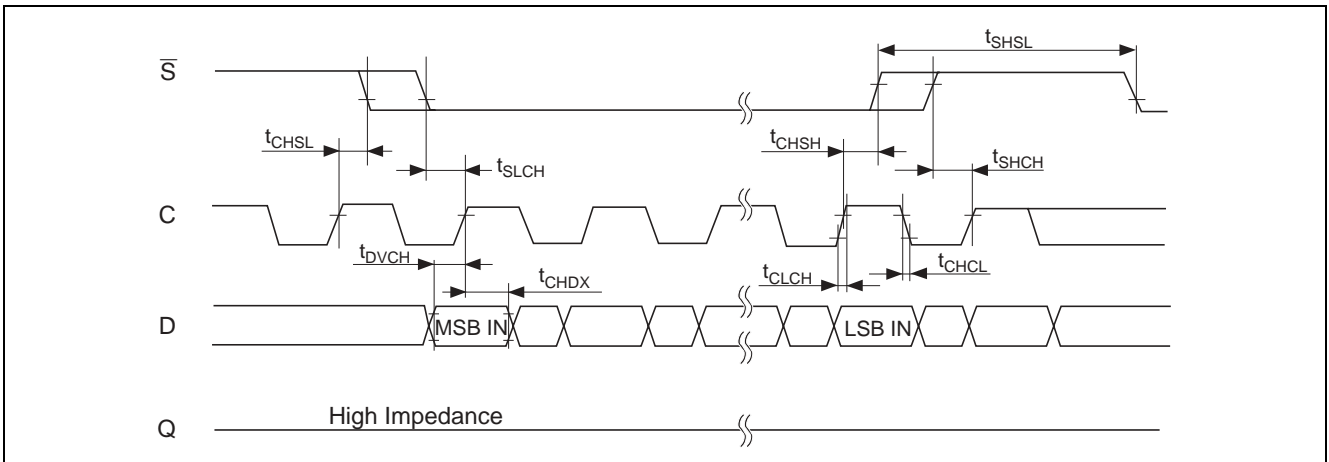

### Hold Timing

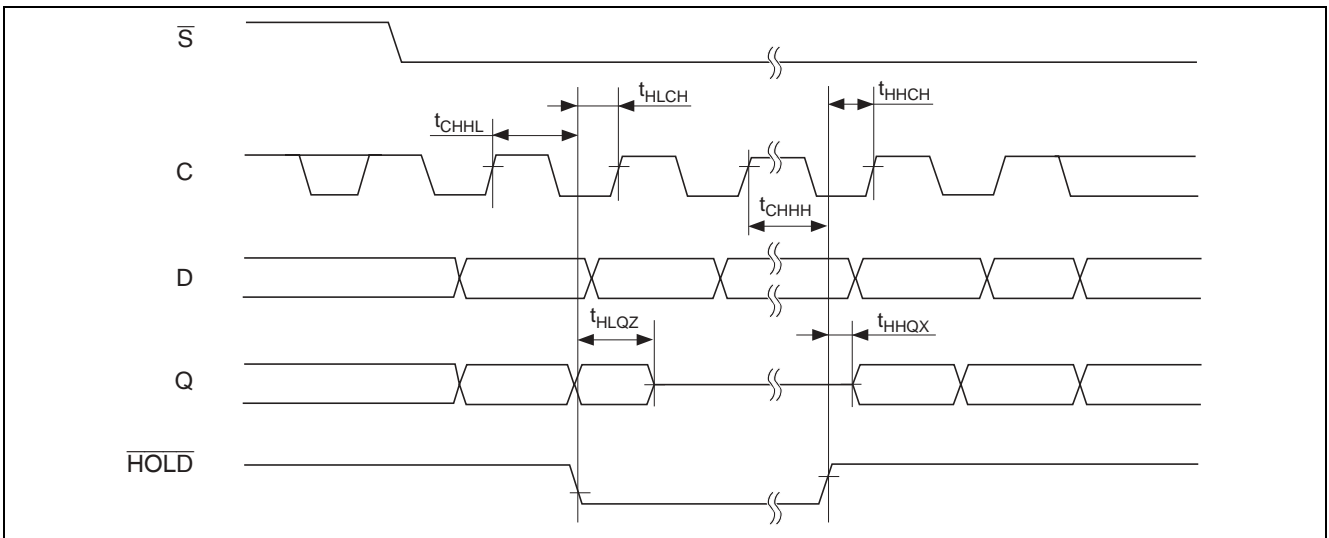

### Output Timing

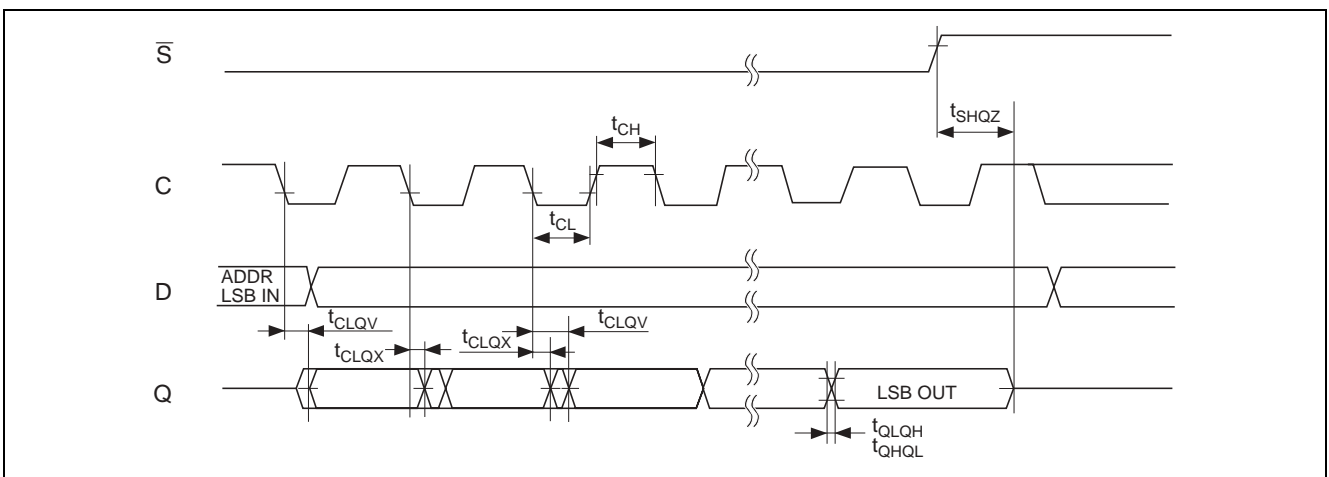

## **Pin Function**

### **Serial data output (Q)**

This output signal is used to transfer data serially out of the device. Data is shifted out on the falling edge of serial clock (C).

### **Serial data input (D)**

This input signal is used to transfer data serially into the device. It receives instructions, addresses, and the data to be written. Values are latched on the rising edge of serial clock (C).

### **Serial clock (C)**

This input signal provides the timing of the serial interface. Instructions, addresses, or data present at serial data input (D) are latched on the rising edge of serial clock (C). Data on serial data output (Q) changes after the falling edge of serial clock (C).

### **Chip select ( $\overline{S}$ )**

When this input signal is high, the device is deselected and serial data output (Q) is at high impedance. Unless an internal write cycle is in progress, the device will be in the standby mode. Driving chip select ( $\overline{S}$ ) low enables the device, placing it in the active power mode. After power-up, a falling edge on chip select ( $\overline{S}$ ) is required prior to the start of any instruction.

### **Hold ( $\overline{HOLD}$ )**

The hold ( $\overline{HOLD}$ ) signal is used to pause any serial communications with the device without deselecting the device. During the hold condition, the serial data output (Q) is high impedance, and serial data input (D) and serial clock (C) are don't care. To start the hold condition, the device must be selected, with chip select ( $\overline{S}$ ) driven low.

### **Write protect ( $\overline{W}$ )**

This input signal is used to protect the memory against write instructions. When write protect ( $\overline{W}$ ) is held low, write instructions (WRSR, WRITE) are ignored. No action on this signal can interrupt a write cycle that has already started.



## Functional Description

### Status Register

The following figure shows the Status Register Format. The Status Register contains a number of status and control bits that can be read or set (as appropriate) by specific instructions.

### Status Register Format

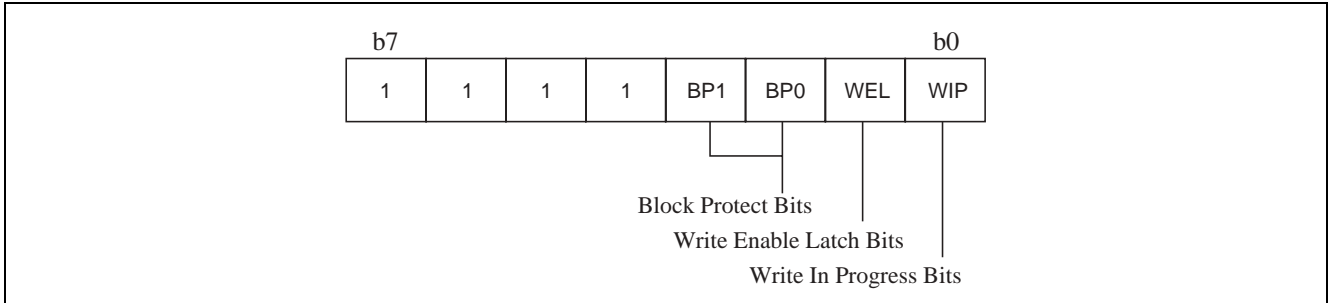

**WIP bit:** The Write In Progress (WIP) bit indicates whether the memory is busy with a Write or Write Status Register cycle.

**WEL bit:** The Write Enable Latch (WEL) bit indicates the status of the internal Write Enable Latch.

**BP1, BP0 bits:** The Block Protect (BP1, BP0) bits are non-volatile. They define the size of the area to be protected against Write instructions.

### Instructions

Each instruction starts with a single-byte code, as summarized in the following table. If an invalid instruction is sent (one not contained in the following table), the device automatically deselects itself.

### Instruction Set

Instruction	Description	Instruction Format
WREN	Write Enable	0000 ×110
WRDI	Write Disable	0000 ×100
RDSR	Read Status Register	0000 ×101
WRSR	Write Status Register	0000 ×001
READ	Read from Memory Array	0000 A011
WRITE	Write to Memory Array	0000 A010

Notes: 1. "×" is Don't care.

2. "A" is A<sub>8</sub> address on the HN58X2504, and Don't care on the HN58X2502.

**Write Enable (WREN):**

The Write Enable Latch (WEL) bit must be set prior to each WRITE and WRSR instruction. The only way to do this is to send a Write Enable instruction to the device. As shown in the following figure, to send this instruction to the device, chip select ( $\overline{S}$ ) is driven low, and the bits of the instruction byte are shifted in, on serial data input (D). The device then enters a wait state. It waits for the device to be deselected, by chip select ( $\overline{S}$ ) being driven high.

**Write Enable (WREN) Sequence**

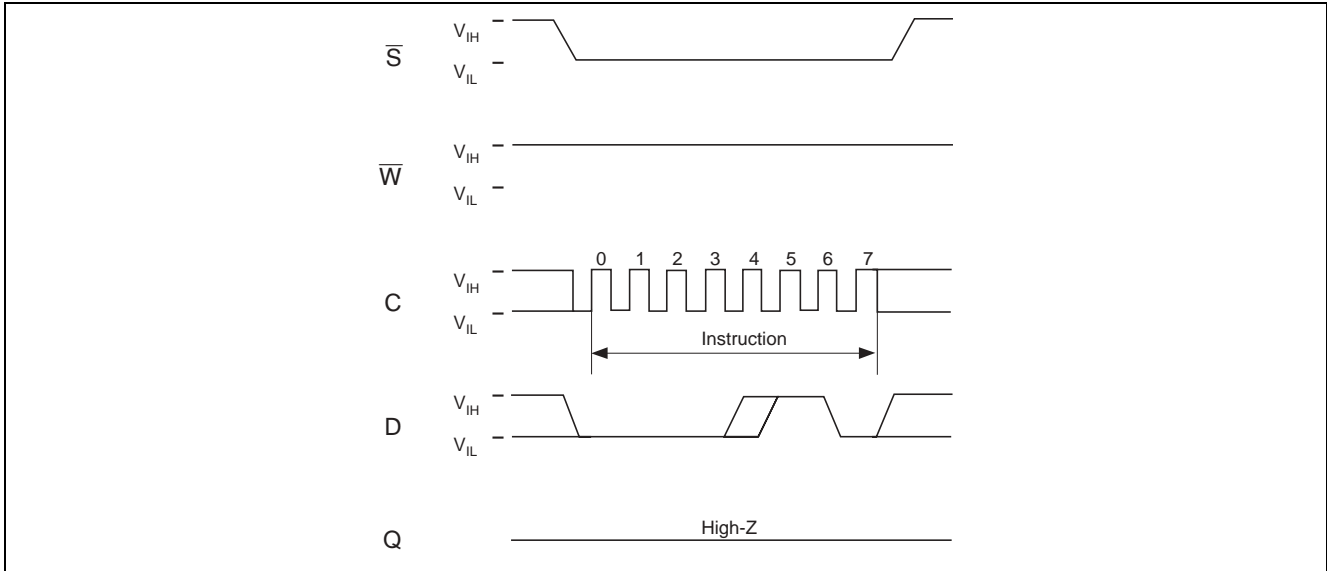

**Write Disable (WRDI):**

One way of resetting the Write Enable Latch (WEL) bit is to send a Write Disable instruction to the device. As shown in the following figure, to send this instruction to the device, chip select ( $\overline{S}$ ) is driven low, and the bits of the instruction byte are shifted in, on serial data input (D).

The device then enters a wait state. It waits for the device to be deselected, by chip select ( $\overline{S}$ ) being driven high. The Write Enable Latch (WEL) bit, in fact, becomes reset by any of the following events:

- Power-up
- WRDI instruction execution
- WRSR instruction completion
- WRITE instruction completion
- WRITE protect ( $\overline{W}$ ) is driven low

**Write Disable (WRDI) Sequence**

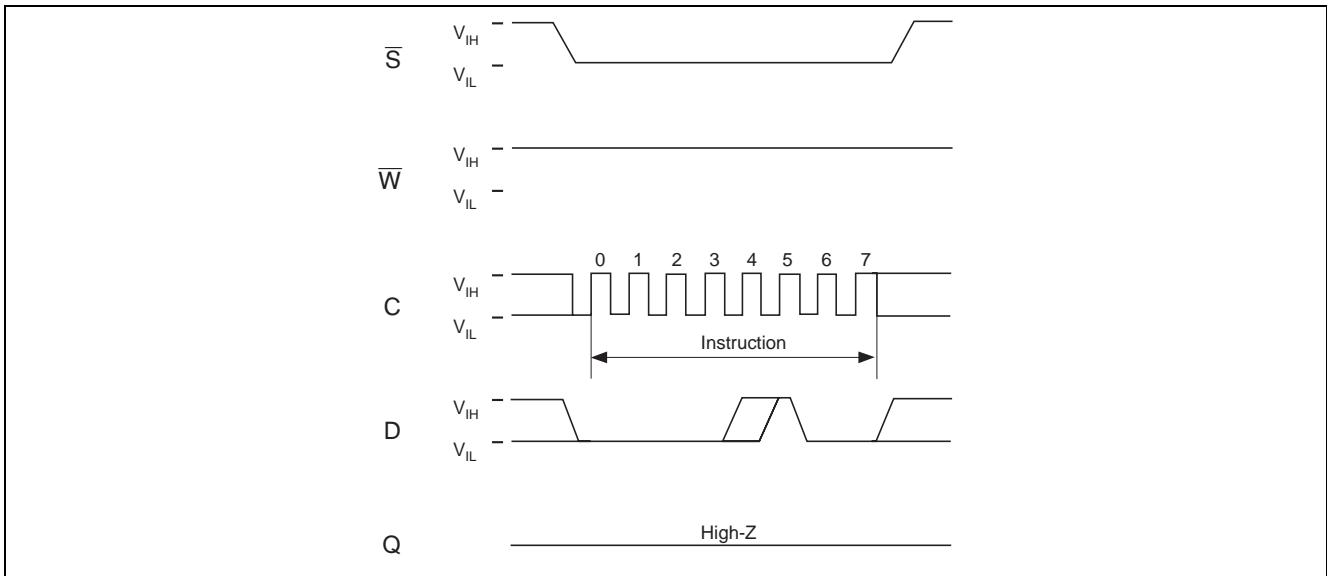

**Read Status Register (RDSR):**

The Read Status Register (RDSR) instruction allows the Status Register to be read. The Status Register may be read at any time, even while a Write or Write Status Register cycle is in progress. When one of these cycles is in progress, it is recommended to check the Write In Progress (WIP) bit before sending a new instruction to the device. It is also possible to read the Status Register continuously, as shown in the following figure.

**Read Status Register (RDSR) Sequence**

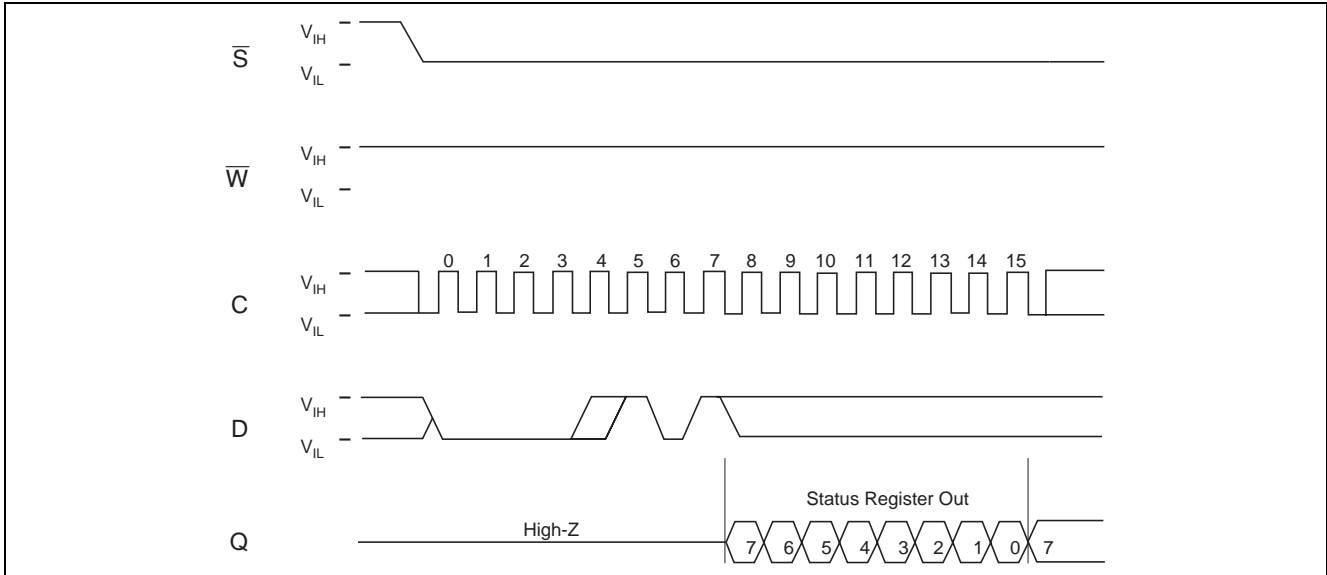

The status and control bits of the Status Register are as follows:

**WIP bit:** The Write In Progress (WIP) bit indicates whether the memory is busy with a Write or Write Status Register cycle. When set to 1, such a cycle is in progress. When reset to 0, no such cycles are in progress.

**WEL bit:** The Write Enable Latch (WEL) bit indicates the status of the internal Write Enable Latch. When set to 1, the internal Write Enable Latch is set. When set to 0, the internal Write Enable Latch is reset and no Write or Write Status Register instructions are accepted.

**BP1, BP0 bits:** The Block Protect (BP1, BP0) bits are non-volatile. They define the size of the area to be software protected against Write instructions. These bits are written with the Write Status Register (WRSR) instruction. When one or both of the Block Protect (BP1, BP0) bits are set to 1, the relevant memory area (as defined in the Status Register Format table) becomes protected against Write (WRITE) instructions. The Block Protect (BP1, BP0) bits can be written provided that the Hardware Protected mode has not been set.

**Write Status Register (WRSR):**

The Write Status Register (WRSR) instruction allows new values to be written to the Status Register. Before it can be accepted, a Write Enable (WREN) instruction must previously have been executed. After the Write Enable (WREN) instruction has been decoded and executed, the device sets the Write Enable Latch(WEL). The instruction sequence is shown in the following figure. The Write Status Register (WRSR) instruction has no effect on b6, b5, b4, b1 and b0 of the Status Register. b6, b5 and b4 are always read as 0. Chip select ( $\bar{S}$ ) must be driven high after the rising edge of serial clock (C) that latches in the eighth bit of the data byte, and before the next rising edge of serial clock (C). Otherwise, the Write Status Register (WRSR) instruction is not executed. As soon as chip select ( $\bar{S}$ ) is driven high, the self-timed Write Status Register cycle (whose duration is  $t_w$ ) is initiated. While the Write Status Register cycle is in progress, the Status Register may still be read to check the value of the Write In Progress (WIP) bit. The Write In Progress (WIP) bit is 1 during the self-timed Write Status Register cycle, and is 0 when it is completed. When the cycle is completed, Write Enable Latch(WEL) is reset. The Write Status Register (WRSR) instruction allows the user to change the values of the Block Protect (BP1, BP0) bits, to define the size of the area that is to be treated as read-only, as defined in the Status Register Format table.

The contents of Block Protect (BP1, BP0) bits are frozen at their current values just before the start of the execution of the Write Status Register (WRSR) instruction. The new, updated values take effect at the moment of completion of the execution of Write Status Register (WRSR) instruction.

**Write Status Register (WRSR) Sequence**

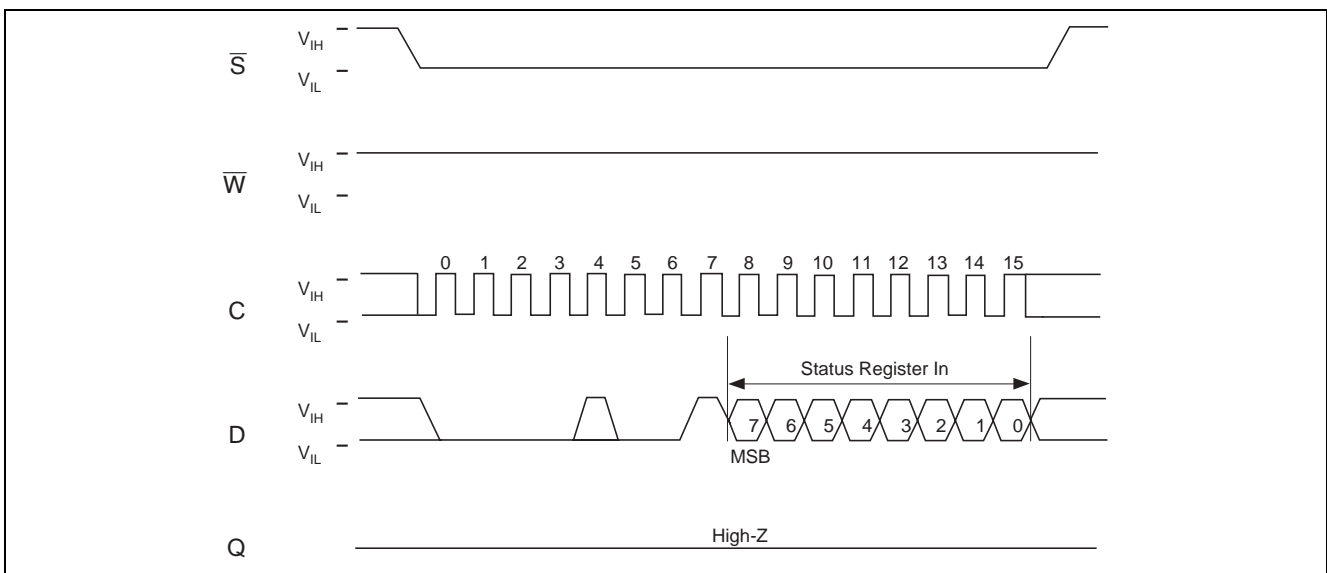

**Read from Memory Array (READ):**

As shown in the following figure, to send this instruction to the device, chip select ( $\bar{S}$ ) is first driven low. The bits of the instruction byte and the address bytes are then shifted in, on serial data input (D). The addresses are loaded into an internal address register, and the byte of data at that address is shifted out, on serial data output (Q). The most significant address (A8) should be sent as fifth bit in the instruction byte.

If chip select ( $\bar{S}$ ) continues to be driven low, the internal address register is automatically incremented, and the byte of data at the new address is shifted out.

When the highest address is reached, the address counter rolls over to zero, allowing the Read cycle to be continued indefinitely. The whole memory can, therefore, be read with a single READ instruction.

The Read cycle is terminated by driving chip select ( $\bar{S}$ ) high. The rising edge of the chip select ( $\bar{S}$ ) signal can occur at any time during the cycle. The addressed first byte can be any byte within any page. The instruction is not accepted, and is not executed, if a Write cycle is currently in progress.

**Read from Memory Array (READ) Sequence**

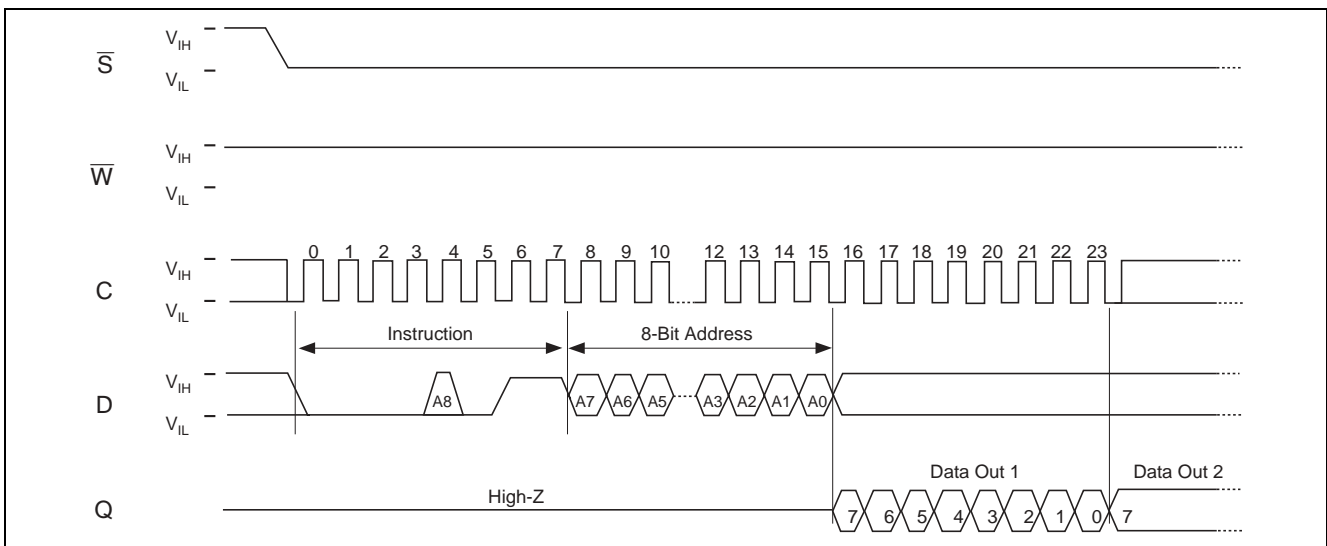

Note: 1. Depending on the memory size, as shown in the following table, the most significant address bits are don't care.

**Address Range Bits**

Device	HN58X2504I	HN58X2502I
Address bits	A8 to A0	A7 to A0

Note: 1. A8 is don't care on the HN58X2402.

**Write to Memory Array (WRITE):**

As shown in the following figure, to send this instruction to the device, chip select ( $\bar{S}$ ) is first driven low. The bits of the instruction byte, address byte, and at least one data byte are then shifted in, on serial data input (D).

The instruction is terminated by driving chip select ( $\bar{S}$ ) high at a byte boundary of the input data. In the case of the following figure, this occurs after the eighth bit of the data byte has been latched in, indicating that the instruction is being used to write a single byte. The self-timed Write cycle starts, and continues for a period  $t_{WC}$  (as specified in AC Characteristics). At the end of the cycle, the Write In Progress (WIP) bit is reset to 0.

If, though, chip select ( $\bar{S}$ ) continues to be driven low, as shown in the following figure, the next byte of the input data is shifted in, so that more than a single byte, starting from the given address towards the end of the same page, can be written in a single internal Write cycle.

Each time a new data byte is shifted in, the least significant bits of the internal address counter are incremented. If the number of data bytes sent to the device exceeds the page boundary, the internal address counter rolls over to the beginning of the page, and the previous data there are overwritten with the incoming data. (The page size of these device is 32 bytes).

The instruction is not accepted, and is not executed, under the following conditions:

- If the Write Enable Latch (WEL) bit has not been set to 1 (by executing a Write Enable instruction just before)
- If a Write cycle is already in progress
- If the addressed page is in the region protected by the Block Protect (BP1 and BP0) bits.
- If Write Protect ( $\bar{W}$ ) is low

**Byte Write (WRITE) Sequence (1 Byte)**

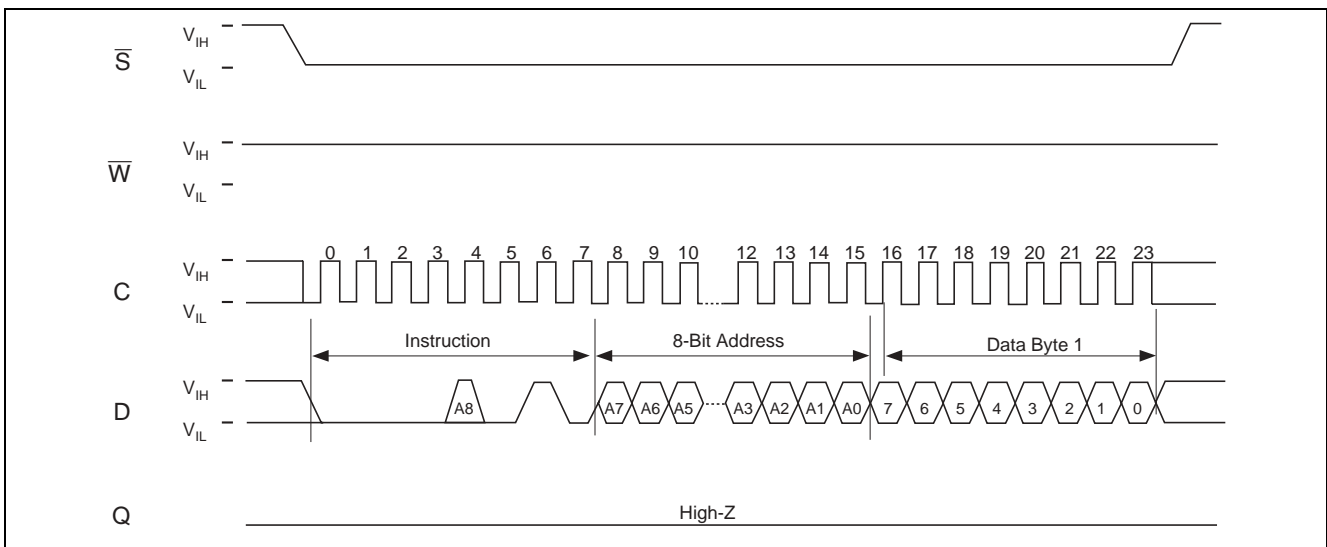

Note: 1. Depending on the memory size, as shown in Address Range Bits table, the most significant address bit is don't care.

Byte Write (WRITE) Sequence (Page)

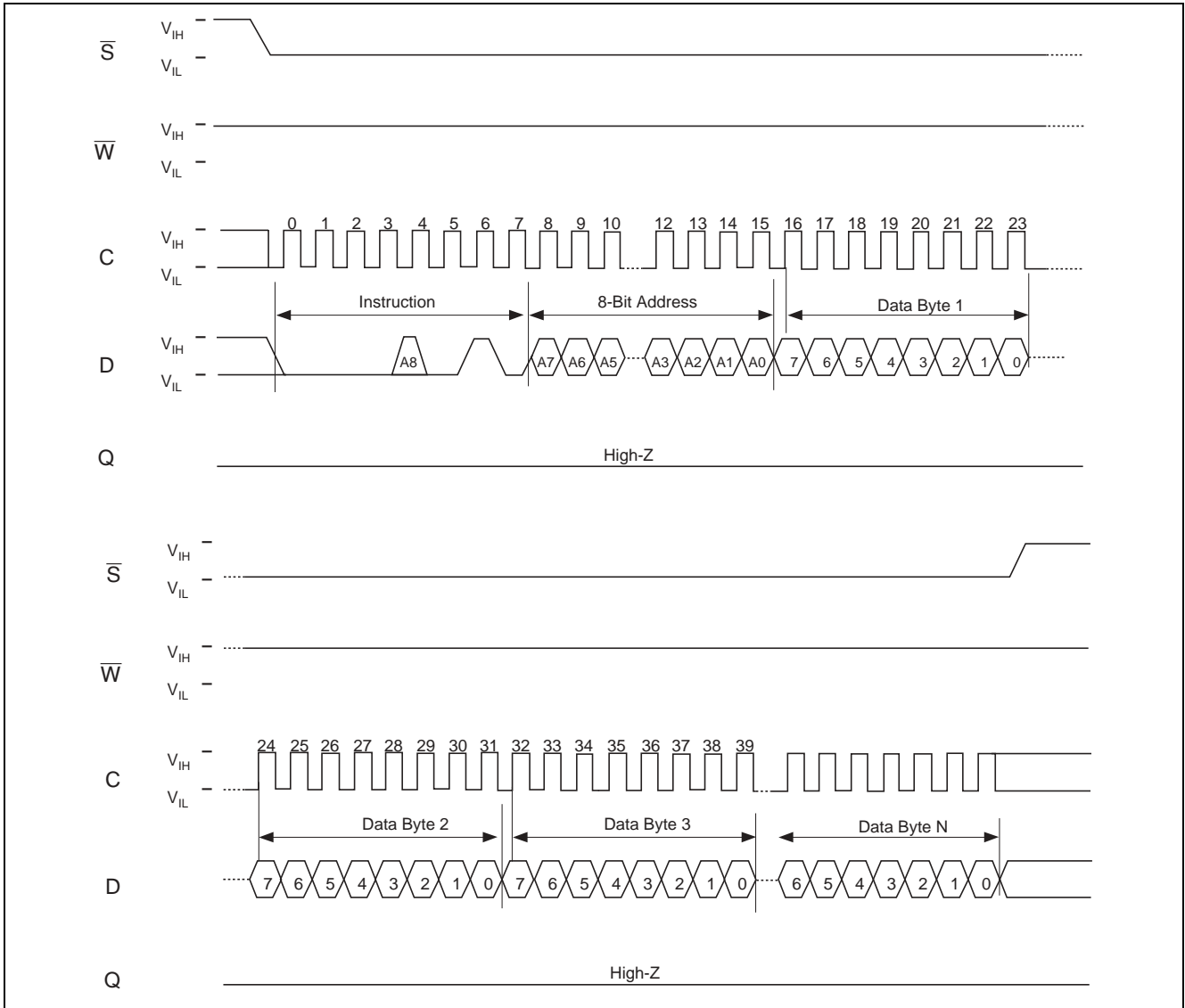

Note: 1. Depending on the memory size, as shown in Address Range Bits table, the most significant address bit is don't care.



## Data Protect

The Block Protect bits (BP1, BP0) define the area of memory that is protected against the execution of write cycle, as summarized in the following table.

When Write Protect ( $\overline{W}$ ) is driven low, write to memory array (WRITE) and write status register (WRSR) are disabled, and WEL bit is reset.

### Write Protected Block Size

Status register bits		Protected blocks	Array addresses protected	
BP1	BP0		HN58X2504I	HN58X2502I
0	0	None	None	None
0	1	Upper quarter	180h – 1FFh	C0h – FFh
1	0	Upper half	100h – 1FFh	80h – FFh
1	1	Whole memory	000h – 1FFh	00h – FFh

## Hold Condition

The hold ( $\overline{HOLD}$ ) signal is used to pause any serial communications with the device without resetting the clocking sequence.

During the hold condition, the serial data output (Q) is high impedance, and serial data input (D) and serial clock (C) are don't care.

To enter the hold condition, the device must be selected, with chip select ( $\overline{S}$ ) low.

Normally, the device is kept selected, for the whole duration of the hold condition. Deselecting the device while it is in the hold condition, has the effect of resetting the state of the device, and this mechanism can be used if it is required to reset any processes that had been in progress.

The hold condition starts when the hold ( $\overline{HOLD}$ ) signal is driven low at the same time as serial clock (C) already being low (as shown in the following figure).

The hold condition ends when the hold ( $\overline{HOLD}$ ) signal is driven high at the same time as serial clock (C) already being low.

The following figure also shows what happens if the rising and falling edges are not timed to coincide with serial clock (C) being low.

### Hold Condition Activation

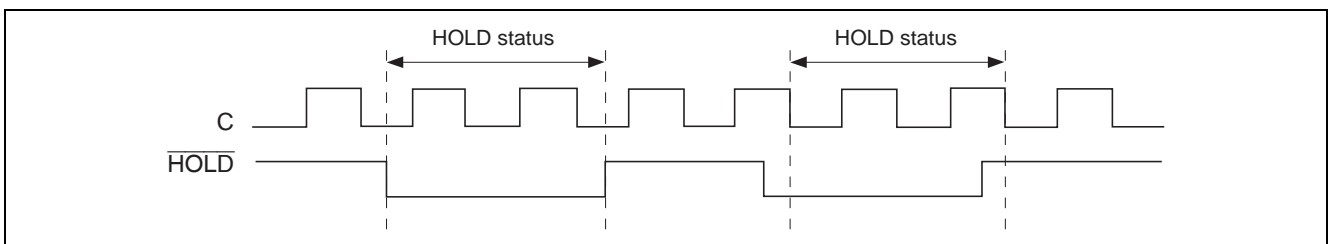

## Notes

### Data Protection at $V_{CC}$ On/Off

When  $V_{CC}$  is turned on or off, noise on  $\bar{S}$  inputs generated by external circuits (CPU, etc) may act as a trigger and turn the EEPROM to unintentional program mode. To prevent this unintentional programming, this EEPROM have a power on reset function. Be careful of the notices described below in order for the power on reset function to operate correctly.

- $\bar{S}$  should be fixed to  $V_{CC}$  during  $V_{CC}$  on/off. Low to high or high to low transition during  $V_{CC}$  on/off may cause the trigger for the unintentional programming.
- $V_{CC}$  should be turned on/off after the EEPROM is placed in a standby state.
- $V_{CC}$  should be turned on from the ground level ( $V_{SS}$ ) in order for the EEPROM not to enter the unintentional programming mode.
- $V_{CC}$  turn on speed should be slower than 10  $\mu\text{s}/\text{V}$ .
- When WRSR or WRITE instruction is executed before  $V_{CC}$  turns off,  $V_{CC}$  should be turned off after waiting write cycle time ( $t_w$ ).

Package Dimensions

HN58X2502FPiE/HN58X2504FPiE (PRSP0008DF-B / Previous Code: FP-8DBV)

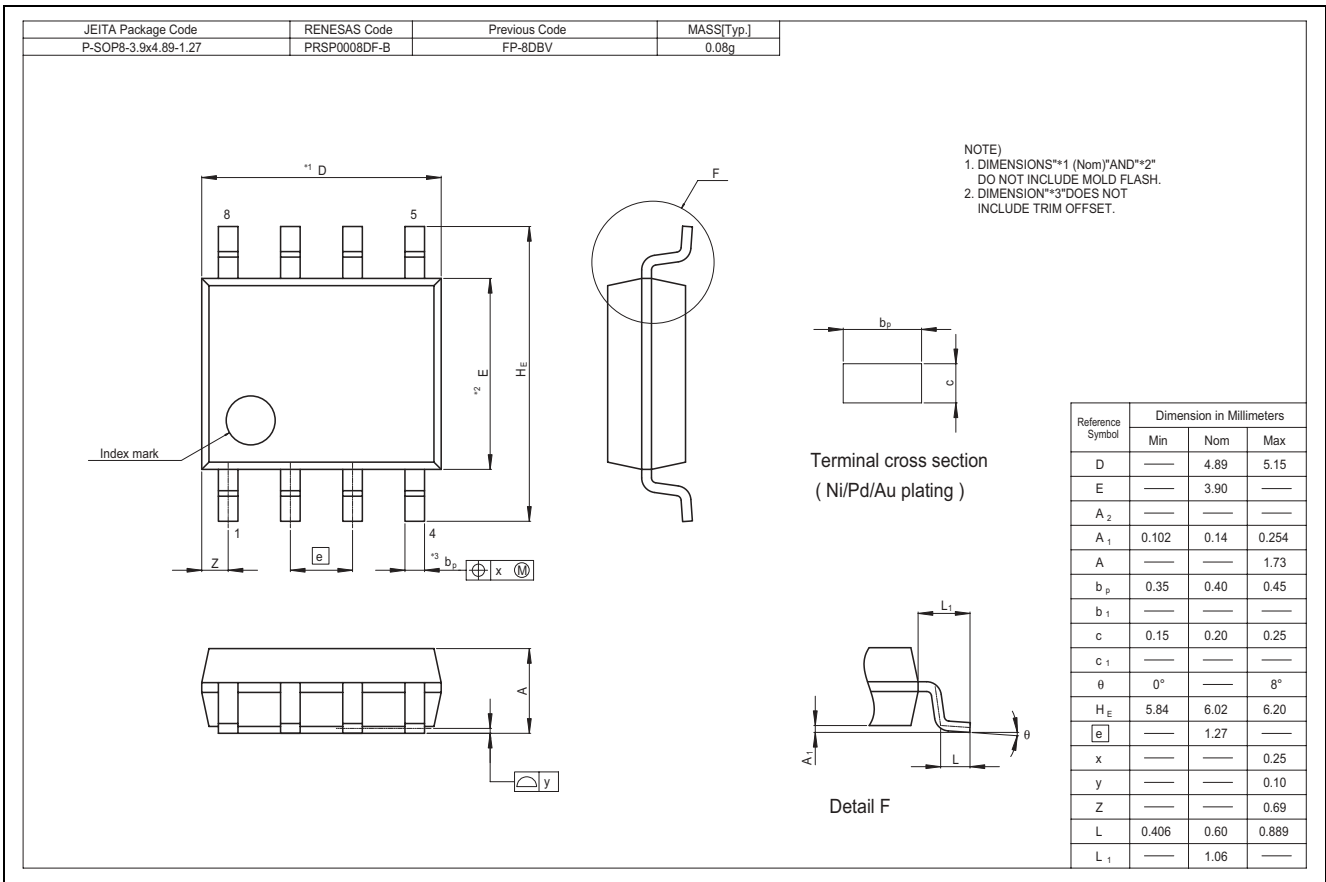

HN58X2502TIE/HN58X2504TIE (PTSP0008JC-B / Previous Code: TTP-8DAV)

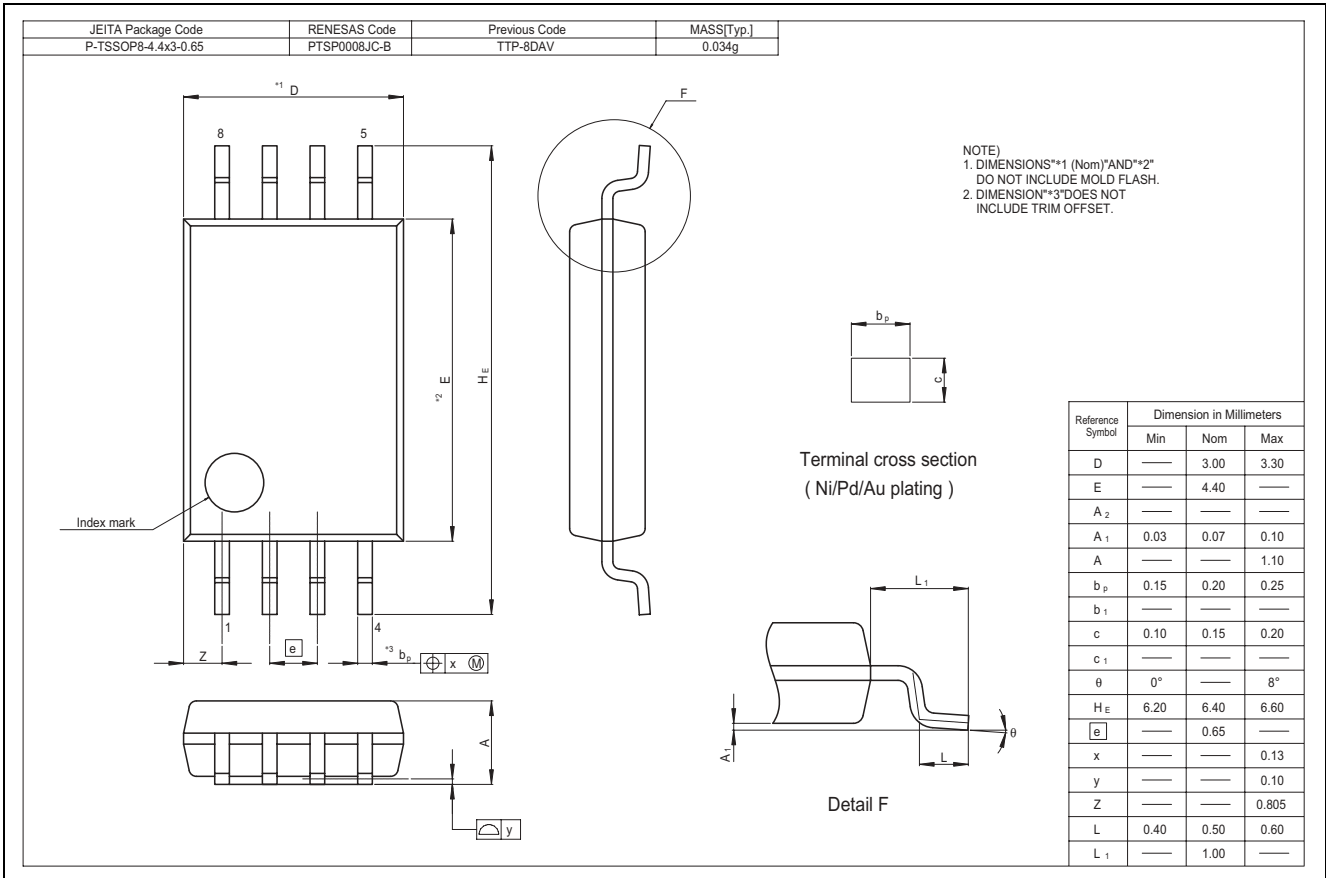

## Revision History

## HN58X2502I/HN58X2504I Data Sheet

Rev.	Date	Contents of Modification	
		Page	Description
0.01	Jul. 29, 2003	—	Initial issue
1.00	Aug.20.2004	— — 2  25-26	Deletion of Preliminary Deletion of Package: SON (TNP-8DA) Ordering Information Deletion of HN58X2502FPI, HN58X2504FPI, HN58X2502TI, HN58X2504TI Addition of HN58X2502FPIE, HN58X2504FPIE, HN58X2502TIE, HN58X2504TIE Package Dimensions: Change of Dimensions FP-8DB to FP-8DBV TTP-8D to TTP-8DAV
1.01	Mar.31.2005	1  2  19-20	Description and Features Change Serial Peripheral Interface for Serial Peripheral Interface compatible Ordering Information Addition of Renesas package codes Package Dimensions Addition of Renesas package codes Changed to Renesas formats
2.00	Jul.05.2005	1  5-6	Features Change of Endurance : $10^5$ Cycles to $10^6$ Erase/Write Cycles AC Characteristics Addition of Erase / Write Endurance Addition of Notes 3

## Renesas Technology Corp. Sales Strategic Planning Div. Nippon Bldg., 2-6-2, Ohte-machi, Chiyoda-ku, Tokyo 100-0004, Japan

Keep safety first in your circuit designs!

1. Renesas Technology Corp. puts the maximum effort into making semiconductor products better and more reliable, but there is always the possibility that trouble may occur with them. Trouble with semiconductors may lead to personal injury, fire or property damage. Remember to give due consideration to safety when making your circuit designs, with appropriate measures such as (i) placement of substitutive, auxiliary circuits, (ii) use of nonflammable material or (iii) prevention against any malfunction or mishap.

Notes regarding these materials

1. These materials are intended as a reference to assist our customers in the selection of the Renesas Technology Corp. product best suited to the customer's application; they do not convey any license under any intellectual property rights, or any other rights, belonging to Renesas Technology Corp. or a third party.
2. Renesas Technology Corp. assumes no responsibility for any damage, or infringement of any third-party's rights, originating in the use of any product data, diagrams, charts, programs, algorithms, or circuit application examples contained in these materials.
3. All information contained in these materials, including product data, diagrams, charts, programs and algorithms represents information on products at the time of publication of these materials, and are subject to change by Renesas Technology Corp. without notice due to product improvements or other reasons. It is therefore recommended that customers contact Renesas Technology Corp. or an authorized Renesas Technology Corp. product distributor for the latest product information before purchasing a product listed herein.  
The information described here may contain technical inaccuracies or typographical errors.  
Renesas Technology Corp. assumes no responsibility for any damage, liability, or other loss rising from these inaccuracies or errors.  
Please also pay attention to information published by Renesas Technology Corp. by various means, including the Renesas Technology Corp. Semiconductor home page (<http://www.renesas.com>).
4. When using any or all of the information contained in these materials, including product data, diagrams, charts, programs, and algorithms, please be sure to evaluate all information as a total system before making a final decision on the applicability of the information and products. Renesas Technology Corp. assumes no responsibility for any damage, liability or other loss resulting from the information contained herein.
5. Renesas Technology Corp. semiconductors are not designed or manufactured for use in a device or system that is used under circumstances in which human life is potentially at stake. Please contact Renesas Technology Corp. or an authorized Renesas Technology Corp. product distributor when considering the use of a product contained herein for any specific purposes, such as apparatus or systems for transportation, vehicular, medical, aerospace, nuclear, or undersea repeater use.
6. The prior written approval of Renesas Technology Corp. is necessary to reprint or reproduce in whole or in part these materials.
7. If these products or technologies are subject to the Japanese export control restrictions, they must be exported under a license from the Japanese government and cannot be imported into a country other than the approved destination.  
Any diversion or reexport contrary to the export control laws and regulations of Japan and/or the country of destination is prohibited.
8. Please contact Renesas Technology Corp. for further details on these materials or the products contained therein.



### RENESAS SALES OFFICES

<http://www.renesas.com>

Refer to "<http://www.renesas.com/en/network>" for the latest and detailed information.

#### **Renesas Technology America, Inc.**

450 Holger Way, San Jose, CA 95134-1368, U.S.A  
Tel: <1> (408) 382-7500, Fax: <1> (408) 382-7501

#### **Renesas Technology Europe Limited**

Dukes Meadow, Millboard Road, Bourne End, Buckinghamshire, SL8 5FH, U.K.  
Tel: <44> (1628) 585-100, Fax: <44> (1628) 585-900

#### **Renesas Technology Hong Kong Ltd.**

7th Floor, North Tower, World Finance Centre, Harbour City, 1 Canton Road, Tsimshatsui, Kowloon, Hong Kong  
Tel: <852> 2265-6688, Fax: <852> 2730-6071

#### **Renesas Technology Taiwan Co., Ltd.**

10th Floor, No.99, Fushing North Road, Taipei, Taiwan  
Tel: <886> (2) 2715-2888, Fax: <886> (2) 2713-2999

#### **Renesas Technology (Shanghai) Co., Ltd.**

Unit2607 Ruijing Building, No.205 Maoming Road (S), Shanghai 200020, China  
Tel: <86> (21) 6472-1001, Fax: <86> (21) 6415-2952

#### **Renesas Technology Singapore Pte. Ltd.**

1 Harbour Front Avenue, #06-10, Keppel Bay Tower, Singapore 098632  
Tel: <65> 6213-0200, Fax: <65> 6278-8001

#### **Renesas Technology Korea Co., Ltd.**

Kukje Center Bldg. 18th Fl., 191, 2-ka, Hangang-ro, Yongsan-ku, Seoul 140-702, Korea  
Tel: <82> 2-796-3115, Fax: <82> 2-796-2145

#### **Renesas Technology Malaysia Sdn. Bhd.**

Unit 906, Block B, Menara Amcorp, Amcorp Trade Centre, No.18, Jalan Persiaran Barat, 46050 Petaling Jaya, Selangor Darul Ehsan, Malaysia  
Tel: <603> 7955-9390, Fax: <603> 7955-9510