

- ◇Structure Silicon monolithic integrated circuit
- ◇Product Series Lens control LSI
- ◇Type BU24025MWV
- ◇Applications Digital still cameras
- ◇Functions •driver (1-5 channels): Voltage control type H-bridge(Adaptable to STM 2 systems)
 •driver (6,7 channels) : Current control type H-bridge

◇Absolute maximum ratings (Ta = 25°C)

Parameter	Symbol	Limits	Unit	Remark
Power supply voltage	DVDD	-0.3~4.5	V	
	MVCC	-0.3~7.0	V	
Input voltage	VIN	-0.3~DVDD+0.3	V	
Input/output current	IIN	±500	mA	Driver block (by MVCC pin)
		+50	mA	by PIOOUT pin
Storage temperature range	TSTG	-55~125	°C	
Operating temperature range	TOPE	-10~85	°C	
Permissible dissipation *1	PD	3000	mW	

This product is not designed for anti-radiation applications.

*1 To use this product at a temperature higher than Ta=25°C, reduce 30mW per 1°C
 (At mounting ROHM's standard board : 74.2mm x 74.2mm x 1.6mm / 4 layer Board)

◇Operating conditions (Ta=25°C)

Parameter	Symbol	Limits	Unit	Remark
Digital power supply voltage	DVDD	2.7~3.6	V	DVDD ≤ MVCC
Driver power supply voltage	MVCC	2.7~5.5	V	
Clock operating frequency	FCLK	1~27.5	MHz	Reference clock

◇ Block Diagram

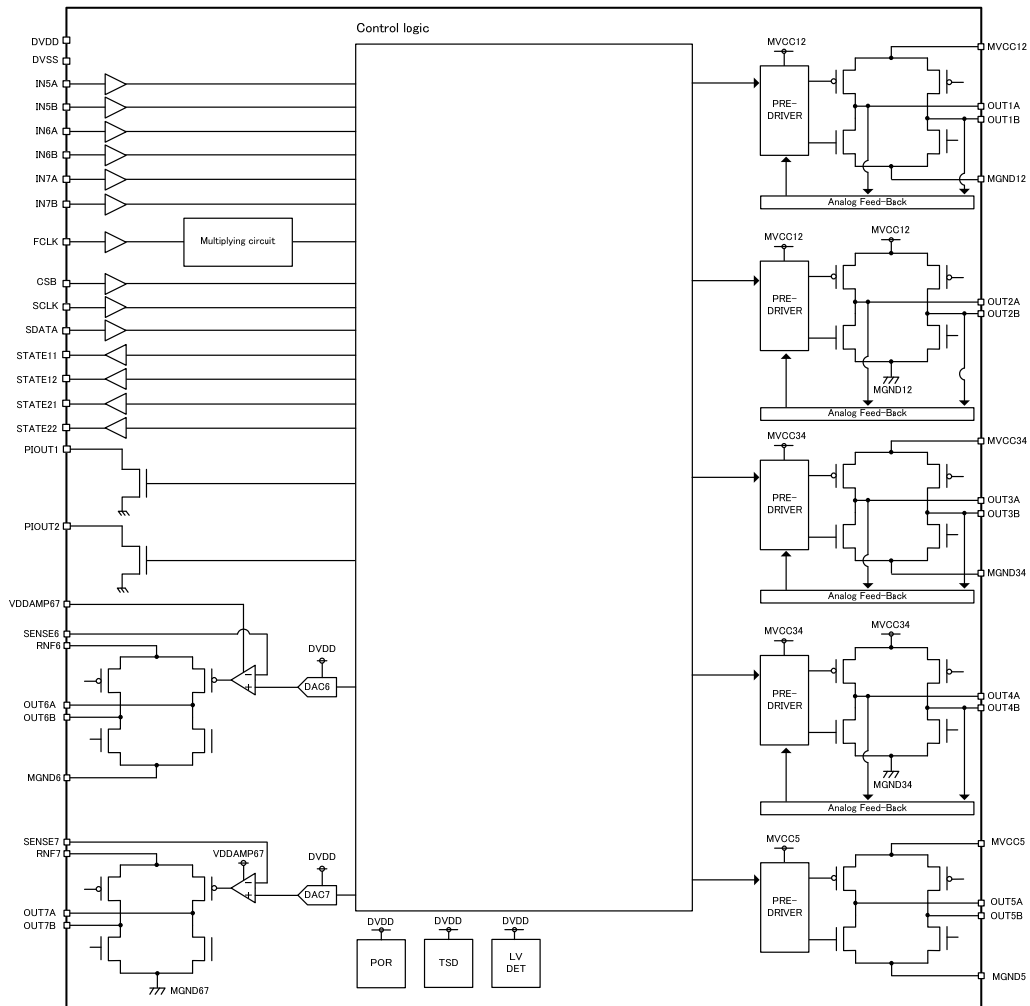

◇ Pin functions

No.	Pin name	Power supply	Function	No.	Pin name	Power supply	Function
1	CSB	DVDD	CSB logic input	23	SENSE6	VDDAMP67	Negative input for 6ch current driver
2	SCLK	DVDD	SCLK logic input	24	VDDAMP67	-	Power supply of 6-7channel current driver control
3	SDATA	DVDD	SDATA logic input	25	OUT6A	RNF6	6-channel driver A output
4	PIOUT1	DVDD	PI driving output1	26	RNF6	RNF6	6-channel driver power supply
5	OUT5A	MVCC5	5-channel driver A output	27	OUT6B	RNF6	6-channel driver B output
6	MVCC5	-	5-channel driver power supply	28	MGND67	-	6-7channel driver ground
7	MGND5	-	5-channel driver ground	29	OUT7A	RNF7	7-channel driver A output
8	OUT5B	MVCC5	5-channel driver B output	30	RNF7	RNF7	7-channel driver power supply
9	DVSS	-	Digital ground	31	OUT7B	RNF7	7-channel driver B output
10	FCLK	DVDD	FCLK logic input	32	SENSE7	VDDAMP67	Negative input for 7ch current driver
11	DVDD	-	Digital power supply	33	IN7A	DVDD	IN7A logic input
12	OUT1A	MVCC12	1-channel drive A output	34	IN7B	DVDD	IN7B logic input
13	MVCC12	-	1-2channel driver power supply	35	STATE11	DVDD	STATE11 logic output
14	OUT1B	MVCC12	1-channel drive B output	36	STATE12	DVDD	STATE12 logic output
15	OUT2A	MVCC12	2-channel drive A output	37	STATE21	DVDD	STATE21 logic output
16	MGND12	-	1-2channel driver ground	38	STATE22	DVDD	STATE22 logic output
17	OUT2B	MVCC12	2-channel drive B output	39	OUT3A	MVCC34	3-channel driver A output
18	PIOUT2	DVDD	PI driving output2	40	MVCC34	-	3-4channel driver power supply
19	IN5A	DVDD	IN5A logic input	41	OUT3B	MVCC34	3-channel driver B output
20	IN5B	DVDD	IN5B logic input	42	OUT4A	MVCC34	4-channel driver A output
21	IN6A	DVDD	IN6A logic input	43	MGND34	-	3-4channel driver ground
22	IN6B	DVDD	IN6B logic input	44	OUT4B	MVCC34	4-channel driver B output

◇ Outline dimensions/Marking figure

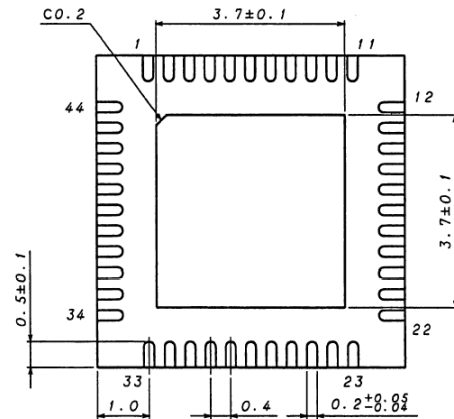
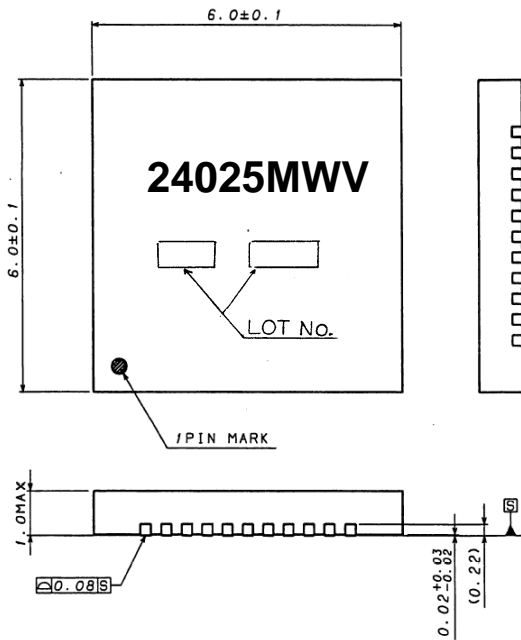

(UNIT: mm)

PKG: UQFN044V6060
Drawing No. EX475-5002-1

◇ Pin assignment diagram

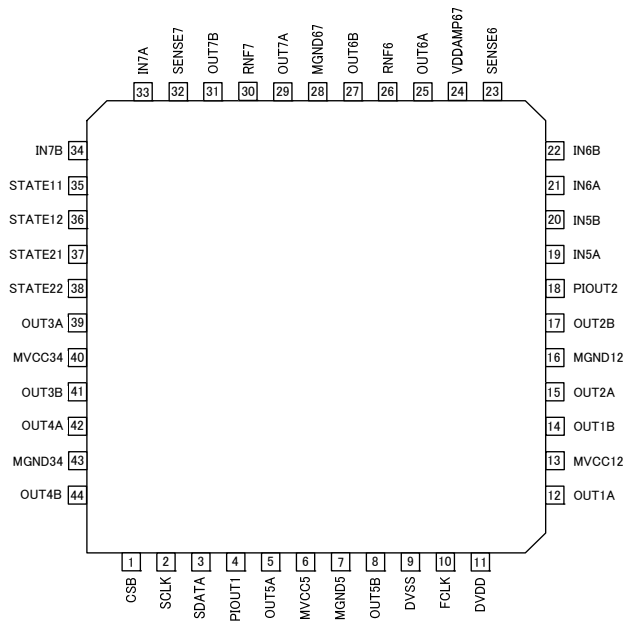

◇Cautions on use

(1) Absolute maximum ratings

If applied voltage, operating temperature range, or other absolute maximum ratings are exceeded, the LSI may be damaged. Do not apply voltages or temperatures that exceed the absolute maximum ratings. If you expect that any voltage or temperature could be exceeding the absolute maximum ratings, take physical safety measures such as fuses to prevent any conditions exceeding the absolute maximum ratings from being applied to the LSI.

(2) GND potential

Maintain the GND pin at the minimum voltage even under any operating conditions.

Actually check to be sure that none of the pins have voltage lower than that of GND pin, including transient phenomena.

(3) Thermal design

With consideration given to the permissible dissipation under actual use conditions, perform thermal design so that adequate margins will be provided.

(4) Short circuit between pins and malfunctions

To mount the LSI on a board, pay utmost attention to the orientation and displacement of the LSI. Faulty mounting to apply a voltage to the LSI may cause damage to the LSI. Furthermore, the LSI may also be damaged if any foreign matters enter between pins, between pin and power supply, or between pin and GND of the LSI.

(5) Operation in strong magnetic field

Make a thorough evaluation on use of the LSI in a strong magnetic field. Not doing so may malfunction the LSI.

Notes

No copying or reproduction of this document, in part or in whole, is permitted without the consent of ROHM Co.,Ltd.

The content specified herein is subject to change for improvement without notice.

The content specified herein is for the purpose of introducing ROHM's products (hereinafter "Products"). If you wish to use any such Product, please be sure to refer to the specifications, which can be obtained from ROHM upon request.

Examples of application circuits, circuit constants and any other information contained herein illustrate the standard usage and operations of the Products. The peripheral conditions must be taken into account when designing circuits for mass production.

Great care was taken in ensuring the accuracy of the information specified in this document. However, should you incur any damage arising from any inaccuracy or misprint of such information, ROHM shall bear no responsibility for such damage.

The technical information specified herein is intended only to show the typical functions of and examples of application circuits for the Products. ROHM does not grant you, explicitly or implicitly, any license to use or exercise intellectual property or other rights held by ROHM and other parties. ROHM shall bear no responsibility whatsoever for any dispute arising from the use of such technical information.

The Products specified in this document are intended to be used with general-use electronic equipment or devices (such as audio visual equipment, office-automation equipment, communication devices, electronic appliances and amusement devices).

The Products specified in this document are not designed to be radiation tolerant.

While ROHM always makes efforts to enhance the quality and reliability of its Products, a Product may fail or malfunction for a variety of reasons.

Please be sure to implement in your equipment using the Products safety measures to guard against the possibility of physical injury, fire or any other damage caused in the event of the failure of any Product, such as derating, redundancy, fire control and fail-safe designs. ROHM shall bear no responsibility whatsoever for your use of any Product outside of the prescribed scope or not in accordance with the instruction manual.

The Products are not designed or manufactured to be used with any equipment, device or system which requires an extremely high level of reliability the failure or malfunction of which may result in a direct threat to human life or create a risk of human injury (such as a medical instrument, transportation equipment, aerospace machinery, nuclear-reactor controller, fuel-controller or other safety device). ROHM shall bear no responsibility in any way for use of any of the Products for the above special purposes. If a Product is intended to be used for any such special purpose, please contact a ROHM sales representative before purchasing.

If you intend to export or ship overseas any Product or technology specified herein that may be controlled under the Foreign Exchange and the Foreign Trade Law, you will be required to obtain a license or permit under the Law.



Thank you for your accessing to ROHM product informations.
More detail product informations and catalogs are available, please contact us.

ROHM Customer Support System

<http://www.rohm.com/contact/>