



## GLASS PASSIVATED SINGLE-PHASE BRIDGE RECTIFIER

### GBPC6005 THRU GBPC610

#### FEATURES

- Plastic package has underwriters laboratory
- Flammability classification 94V-0
- Glass passivated ship junction
- High case dielectric with standing voltage of 1500V<sub>RMS</sub>
- Typical I<sub>r</sub> less than 0.5 μA
- High surge current capability
- Ideal for printed circuit boards
- High temperature soldering guaranteed 260/10 seconds, 0.375" (9.5mm) lead length at 5 lbs (2.3kg) tension

#### MECHANICAL DATA

- Case: Epoxy, Molded Plastic body over passivated junctions
- Terminal: Plated leads solderable per MIL-STD-750 method 2026
- Mounting position: Any (Note 1)
- Weight: 0.1 ounce, 2.8 gram

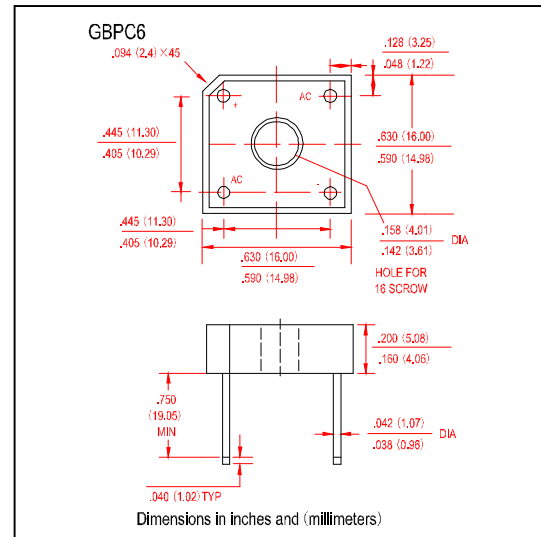

#### MAXIMUM RATINGS AND ELECTRICAL CHARACTERISTICS

- Ratings at 25°C ambient temperature unless otherwise specified

	SYMBOLS	GBPC 6005	GBPC 601	GBPC 602	GBPC 604	GBPC 606	GBPC 608	GBPC 610	UNIT
Maximum Repetitive Peak Reverse Voltage	V <sub>RRM</sub>	50	100	200	400	600	800	1000	Volts
Maximum RMS Voltage	V <sub>RMS</sub>	35	70	140	280	420	560	700	Volts
Maximum DC Blocking Voltage	V <sub>DC</sub>	50	100	200	400	600	800	1000	Volts
Maximum Average Forward output current at	T <sub>C</sub> =50°C(Note2)	6.0							Amps
	T <sub>A</sub> =40°C(Note3)	3.0							
Peak Forward Surge Current single half sine-wave superimposed on rated load (JEDEC method)	I <sub>FSM</sub>	125							Amps
Maximum Instantaneous Forward Voltage Drop Per element per leg 3.0A	V <sub>F</sub>	1.0							Volts
Rating for Fusing (t<8.3ms)	I <sup>2</sup> t	1.0							A <sup>2</sup> s
Maximum DC Reverse Current at rated DC Blocking Voltage per leg	T <sub>A</sub> = 25°C	5.0							μA
	T <sub>A</sub> = 125°C	500							
Typical Junction Capacitance per leg at 4.0V, 1 MHz	C <sub>j</sub>	186				90			pF
Typical Thermal Resistance per leg (NOTE 1)	R <sub>θJL</sub>	7.3							°C/W
	R <sub>θJA</sub>	22							
Operating and Storage Temperature Range	T <sub>J</sub> , T <sub>STG</sub>	(-55 to +150)							°C

- Notes:**
1. Bolt down on heatsink with silicon thermal compound between bridge and mounting surface for maximum heat transfer with #6 screw.
  2. Unit mounted 5.0"×6.0"×0.11" thick(10.5×10.5×0.3cm)A1..Plate.
  3. Unit mounted on P.C.B. at 0.375"(9.5mm) lead with 0.5"×0.5"(12×12mm) copper pads



# GLASS PASSIVATED SINGLE-PHASE BRIDGE RECTIFIER

## GBPC6005 THRU GBPC610

### RATINGS AND CHARACTERISTICS CURVES GBPC6005 THRU GBPC610

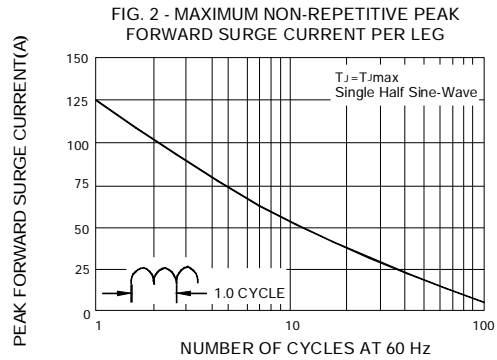
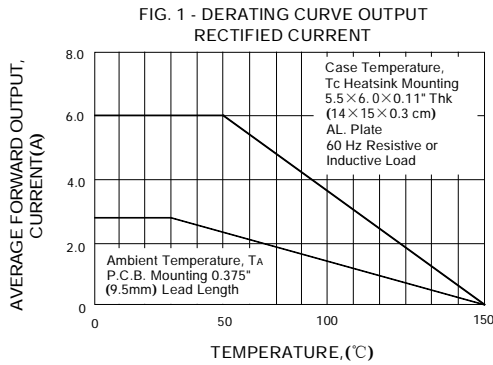

FIG. 3 - TYPICAL FORWARD CHARACTERISTICS PER LEG

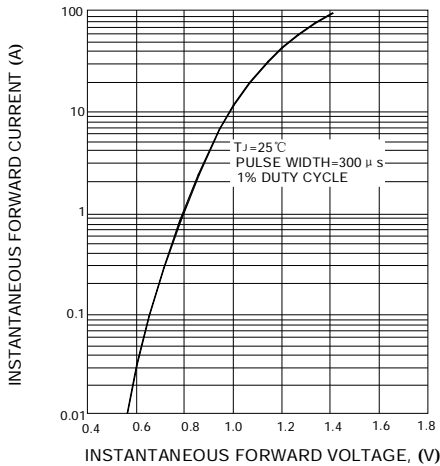

FIG. 4 - TYPICAL REVERSE LEAKAGE CHARACTERISTICS PER LEG

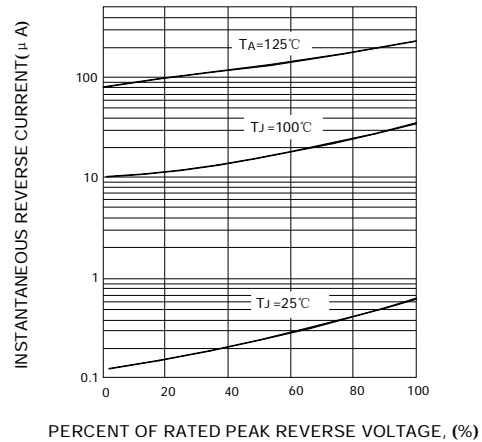

FIG. 5 - TYPICAL JUNCTION CAPACITANCE PER LEG

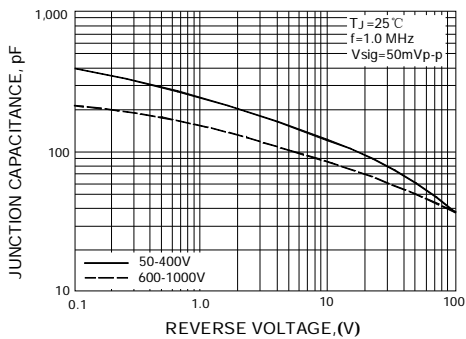

FIG. 6 - TYPICAL TRANSIENT THERMAL IMPEDANCE PER LEG

