

SMBJ18A

Transient Voltage Suppressors

Pppm: 600W

IFSM: 100A



FEATURE

- Low profile package
- Ideal for surface mount pick and place applications
- Excellent clamping capability
- Very fast response time
- Low incremental surge resistance
- Glass passivated chip junction
- High temperature soldering guaranteed
- 260°C/10sec/at terminals

MECHANICAL DATA

Terminal: Plated axial leads solderable per MIL-STD 202E, method 208C
Case: Molded with UL-94 Class V-0 recognized Flame Retardant Epoxy
Polarity: color band denotes cathode end
Mounting position: any

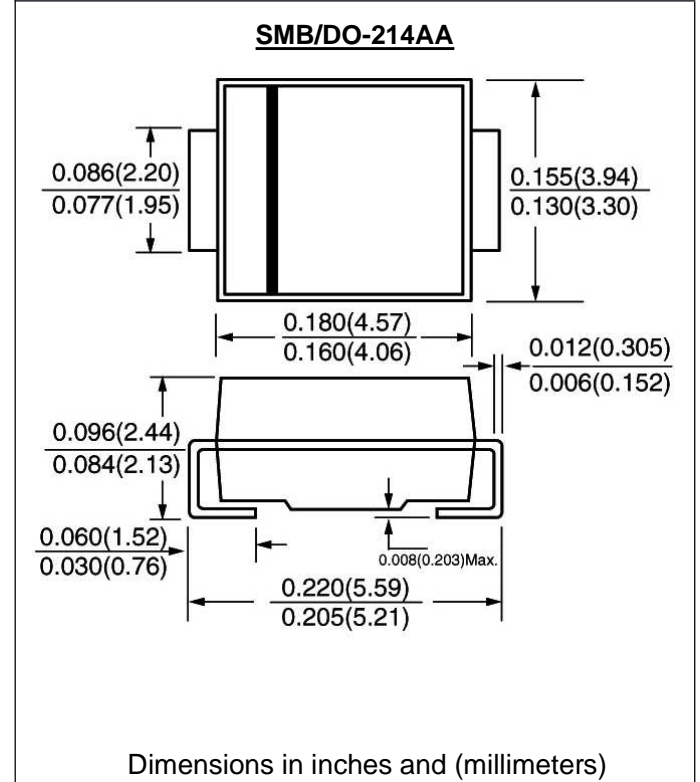

MAXIMUM RATINGS (TA = 25 °C unless otherwise noted)

Parameter	Symbol	SMBJ18A	units
Peak pulse power dissipation with a 10/1000 μ s waveform ^(1,2) (Fig. 1)	P _{PPM}	600	W
Peak pulse current with a 10/1000 μ s waveform ⁽¹⁾	I _{PPM}	18.6	A
Breakdown Voltage at I _T =1mA	V _{BR}	20.0min 24.4max	V
Maximum Reverse Leakage at V _{WM} =18V	I _R	1.0	μ A
Maximum Clamping Voltage at IPPM	V _C	32.2	V
Peak forward surge current 8.3 ms single half sine-wave uni-directional only ⁽²⁾	I _{FSM}	100	A
Maximum instantaneous forward voltage at 50A for uni-directional only	V _F	3.5	V
Typical thermal resistance, junction-to-lead	R _{th(jl)}	20	°C/W
Typical thermal resistance, junction-to-ambient	R _{th(ja)}	100	°C/W
Operating junction and Storage temperature range	T _j , T _{stg}	-55 to +150	°C

Note:
(1) Non-repetitive current pulse, per Fig. 3 and derated above TA = 25 °C per Fig. 2
(2) Mounted on 0.2x0.2" (5.0x5.0mm) copper pads to each terminal

RATINGS AND CHARACTERISTIC CURVES SMBJ18A

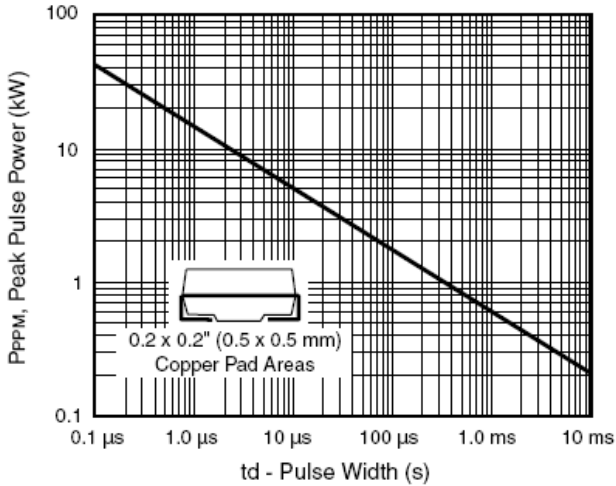

Figure 1. Peak Pulse Power Rating Curve

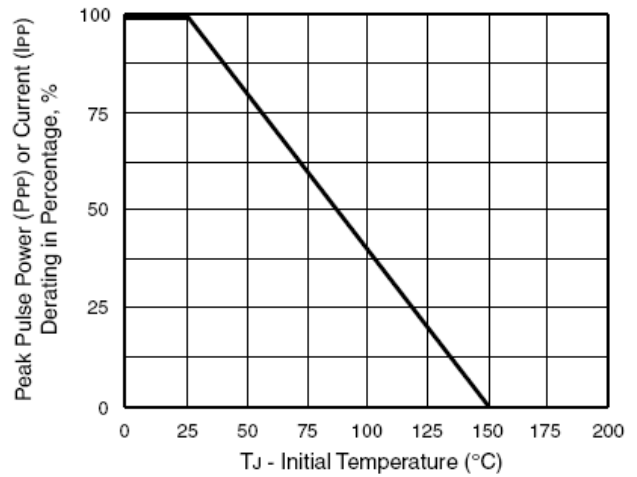

Figure 2. Pulse Power or Current versus Initial Junction Temperature

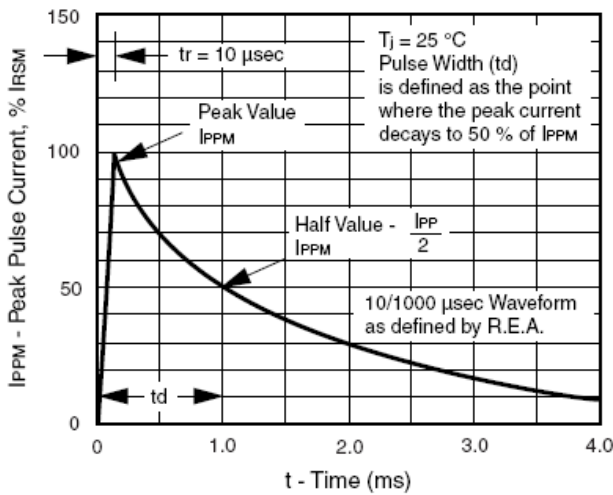

Figure 3. Pulse Waveform

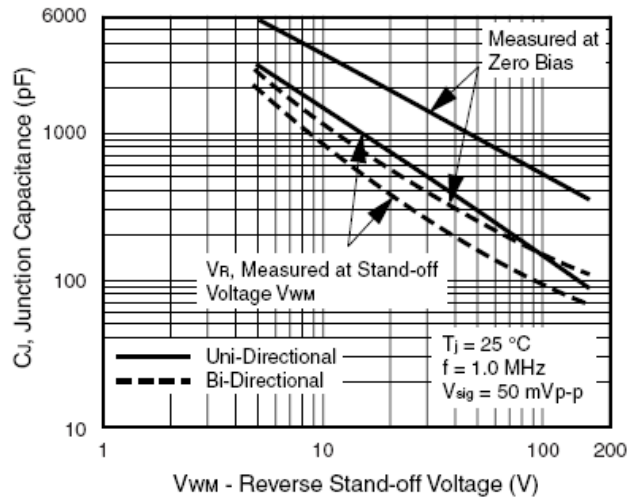

Figure 4. Typical Junction Capacitance

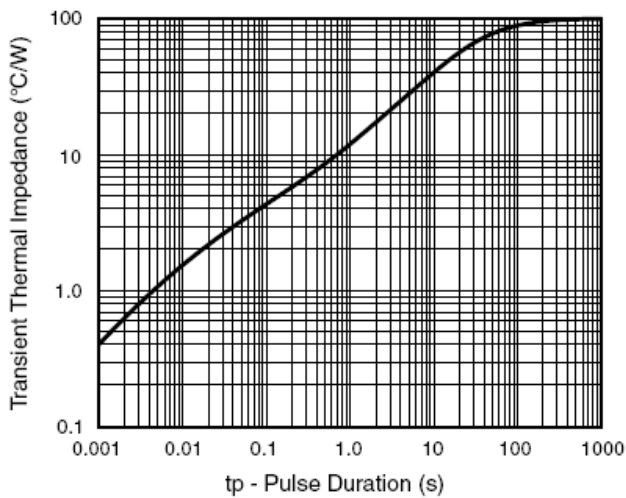

Figure 5. Typical Transient Thermal Impedance

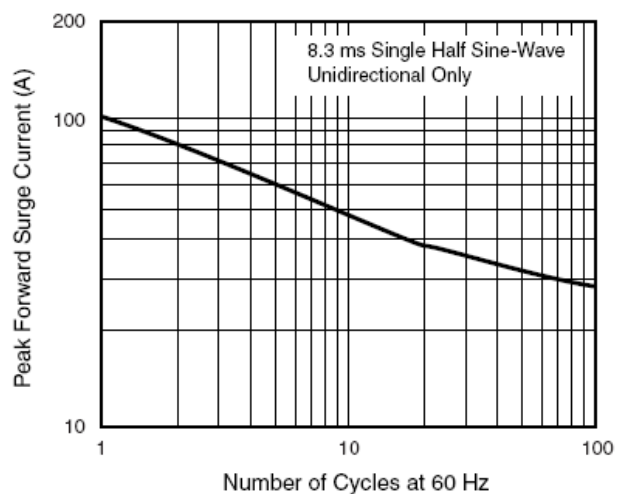

Figure 6. Maximum Non-Repetitive Peak Forward Surge Current