



RBA Series

Signal conditioned pressure sensors

FEATURES

- 0...10 inch H₂O to 0...100 psi, 0...±5 inch H₂O to 0...±100 psi, absolute, gage or differential pressure
- 0.5...4.5 V ratiometric output
- Precision ASIC signal conditioning
- Temperature compensated
- Sensortech PRO services

MEDIA COMPATIBILITY

To be used with non-corrosive, non-ionic working fluids such as clean dry air, dry gases and the like.

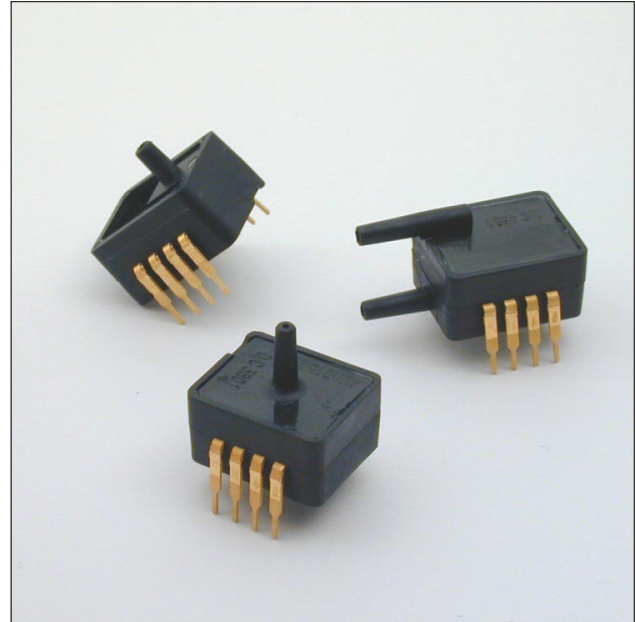

SPECIFICATIONS

Maximum ratings

Supply voltage V_s max. $6.50 V_{DC}$	4.75 V to 5.25 V_{DC}
Output current Sink	2 mA
Source	2 mA
Lead temperature (2 - 4 sec.)	250 °C
Temperature ranges Compensated	0 to +85 °C
Operating	-20 to +105 °C
Storage	-40 to +125 °C
Vibration	10 g at 20 - 2000 Hz
Shock RBAP...	100 g for 11 ms
RBAH...	50 g for 11 ms

Caution!

The sensors are not reverse polarity protected. Incorrect applications of excitation voltage or ground to the wrong pin can cause electrical failure. Application of supply voltage above the maximum can cause electrical failure.

ELECTRICAL CONNECTION

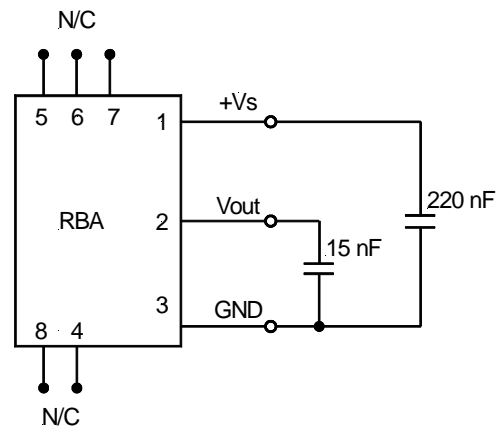

Note: Capacitor 220 nF required between +Vs and GND and 15 nF between Vout and GND.

It is important to place the capacitors as close to the pins as possible!

Pins 4, 5, 6, 7 and 8 are internal device connections and should not be connected for any reason!



PRESSURE RANGES SPECIFICATIONS

($V_S = 5.0 V_{DC}$, $T_A = 25^\circ C$)

Part number	Pressure range	Burst pressure ¹		Sensitivity (typ.)	
RBAH005DB	0...±5	"H ₂ O	3	psi	0.400
RBAH010DB	0...±10		3		0.200
RBAH010DU	0...10		3		0.400
RBAP015AU	0...15	psi(a)	30	psi(a)	0.267
RBAP030AU	0...30		60		0.133
RBAP100AU	0...100		150		0.040
RBAP001(G,D)U	0...1	psi(g)	5	psi(g)	4.00
RBAP005(G,D)U	0...5		20		0.80
RBAP015(G,D)U	0...15		30		0.267
RBAP030(G,D)U	0...30		60		0.133
RBAP100(G,D)U	0...100		150		0.040
RBAP001DB	0...±1		psi(d)		5
RBAP005DB	0...±5	20		0.40	
RBAP015DB	0...±15	30		0.133	
RBAP030DB	0...±30	60		0.067	
RBAP100DB	0...±100	150		0.020	

Specification notes:

1. If maximum burst pressure is exceeded, even momentarily, the package may leak or burst, or the pressure sensing die may fracture.
2. Full Scale Span (FSS) is the algebraic difference between the output signal for the highest and lowest specified pressure. Span is ratiometric to the supply voltage.
3. Total accuracy is the combined error from offset and span calibration, linearity, pressure hysteresis, and temperature effects. Linearity is the measured deviation based on a straight line. Hysteresis is the maximum output difference at any point within the operating pressure range for increasing and decreasing pressure. Calibration errors include the deviation of offset and full scale from nominal values.
4. Delay time between sampling and signal change at the output.
5. The smallest change in the output voltage, given any change in pressure.
6. This is the maximum temperature shift for offset when measured between 0...85 °C relative to the 25 °C reading.



RBA Series

Signal conditioned pressure sensors

PERFORMANCE CHARACTERISTICS

0.5 to 4.5 V ratiometric output ($V_s = 5.0 V_{DC}$, $T_A = 25^\circ C$)

All RBA...U (unidirectional devices)

Characteristics		Min.	Typ.	Max.	Units
Zero pressure offset	RBAH010DU	0.40	0.50	0.60	V
	all others	0.42	0.50	0.58	
Full scale span (FSS) ²			4.00		
Full scale output	RBAH010DU	4.40	4.50	4.60	
	all others	4.42	4.50	4.58	
Total accuracy (0...85°C) ³	RBAH010DU			±2.5	%FSS
	all others			±2.0	
Temperature effect on offset ⁶	RBAH010DU			±100	mV
	all RBAP...GU, ...DU			±80	
Sample rate		100			Hz
Response delay ⁴		2.73		14.11	ms
Quantization step ⁵			3		mV
Current consumption			6		mA

All RBA...B (bidirectional devices)

Characteristics		Min.	Typ.	Max.	Units
Zero pressure offset	RBAH...DB	2.40	2.50	2.60	V
	all others	2.42	2.50	2.58	
Full scale span (FSS) ²			4.00		
Output	at max. specified pressure	RBAH...DB	4.40	4.50	
		all others	4.42	4.50	4.58
	at min. specified pressure	RBAH...DB	0.40	0.50	0.60
		all others	0.42	0.50	0.58
Total accuracy (0...85°C) ³	RBAH...DB			±2.5	%FSS
	all others			±2.0	
Temperature effect on offset ⁶	RBAH...DB			±100	mV
	all others			±80	
Sample rate		100			Hz
Response delay ⁴		2.73		14.11	ms
Quantization step ⁵			3		mV
Current consumption			6		mA



RBA Series

Signal conditioned pressure sensors

PHYSICAL DIMENSIONS

Differential (D) package

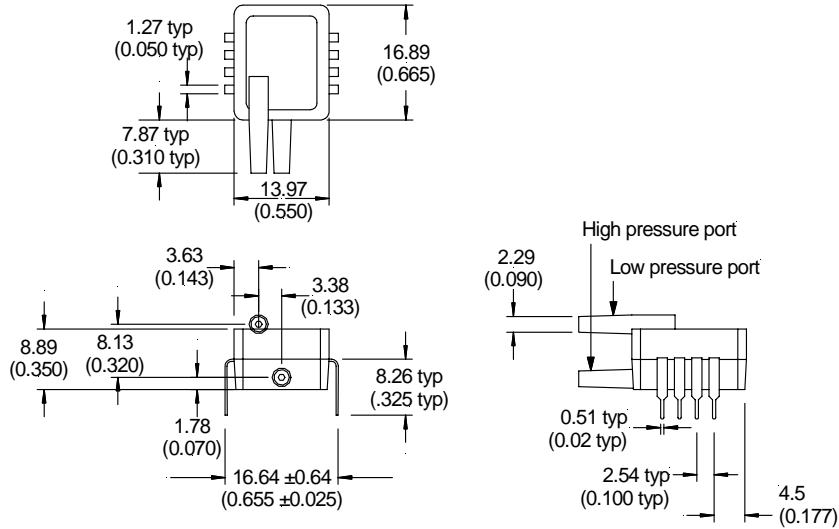

Gage (G) package

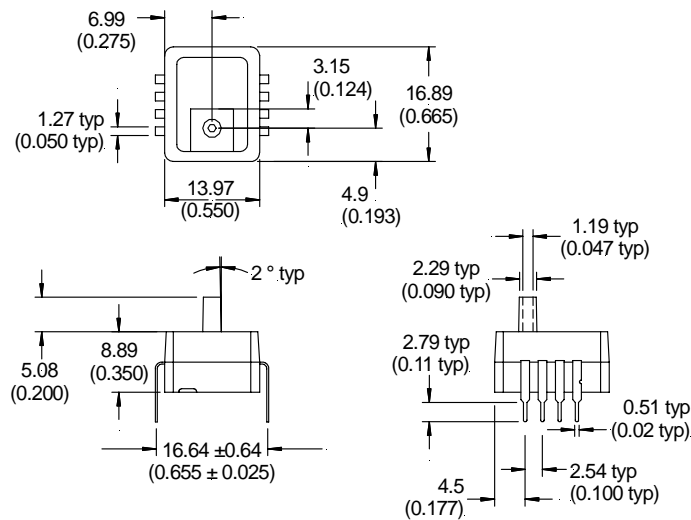

Absolute (A) package

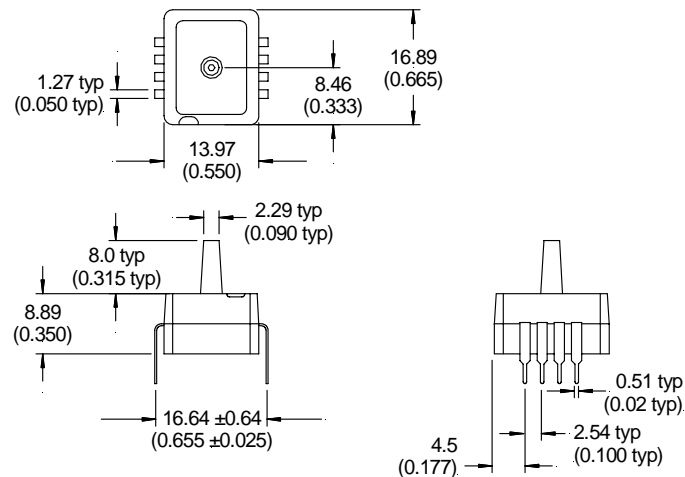

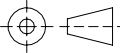

third angle projection
dimensions in mm (inches)



RBA Series

Signal conditioned pressure sensors

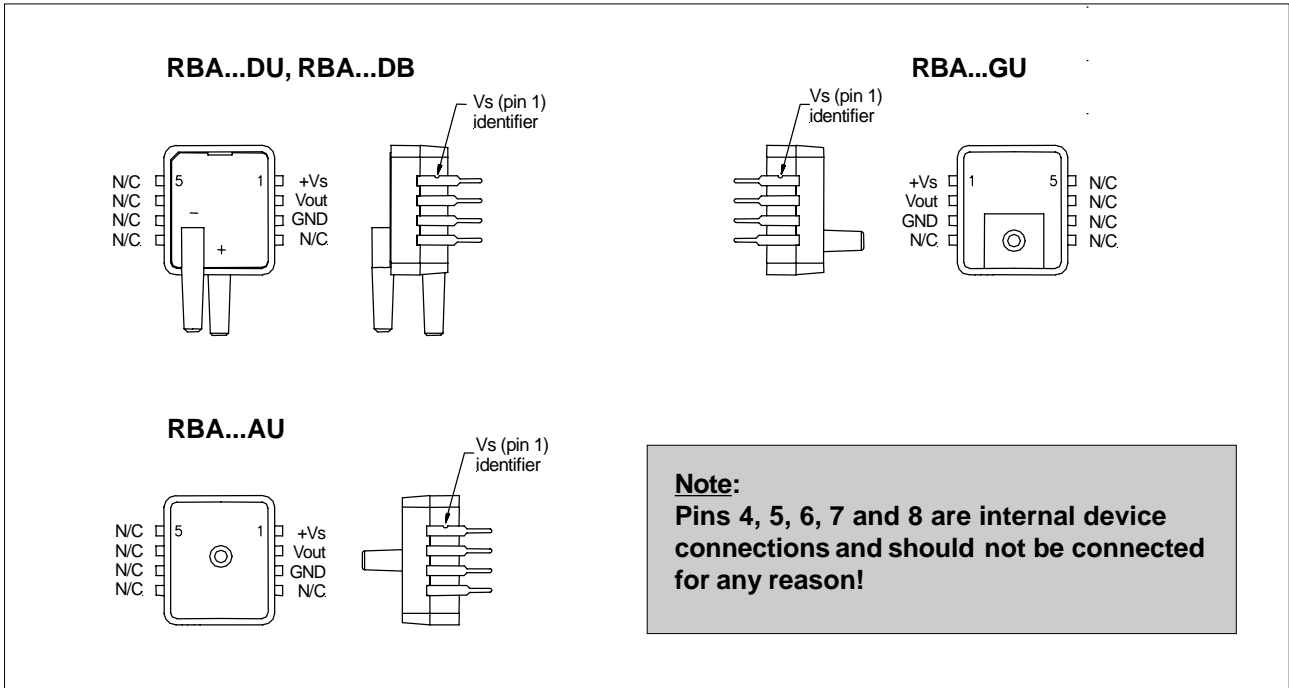
ELECTRICAL CONNECTIONS



TOTAL ACCURACY (-20 to +105°C)

For all RBAP... devices

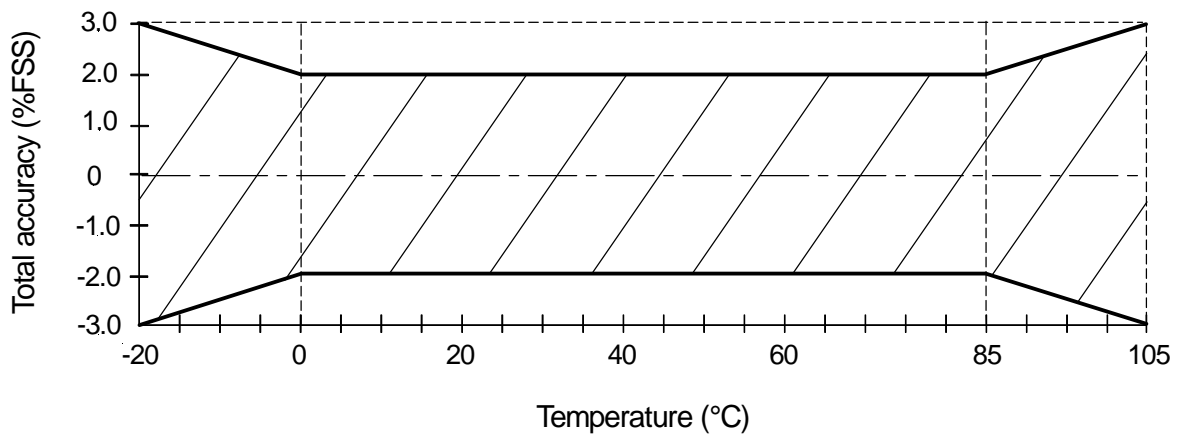



RBA Series

Signal conditioned pressure sensors

ORDERING INFORMATION - AVAILABLE LISTINGS

Note: Preferred listings are highlighted in grey

Pressure range	Absolute (A)	Gage (G)	Differential (D)
Unidirectional (U)			
0...10 inch H ₂ O			RBAH010DU
0...1 psi		RBAP001GU	RBAP001DU
0...5 psi		RBAP005GU	RBAP005DU
0...15 psi	RBAP015AU	RBAP015GU	RBAP015DU
0...30 psi	RBAP030AU	RBAP030GU	RBAP030DU
0...100 psi	RBAP100AU	RBAP100GU	RBAP100DU
Bidirectional (B)			
0...±5 inch H ₂ O			RBAH005DB
0...±10 inch H ₂ O			RBAH010DB
0...±1 psi			RBAP001DB
0...±5 psi			RBAP005DB
0...±15 psi			RBAP015DB
0...±30 psi			RBAP030DB
0...±100 psi			RBAP100DB

Sensortech PRO services:

- Extended guarantee period of 2 years
- Improved performance characteristics
- Custom product modifications and adaptations even for small quantities
- Advanced logistics models for supply inventory and short delivery times
- Technical support through application engineers on the phone or at your site
- Fastest possible technical response for design and QA engineers
- ... plus other services on request

Sensortech reserves the right to make changes to any products herein. Sensortech does not assume any liability arising out of the application or use of any product or circuit described herein, neither does it convey any license under its patent rights nor the rights of others.