

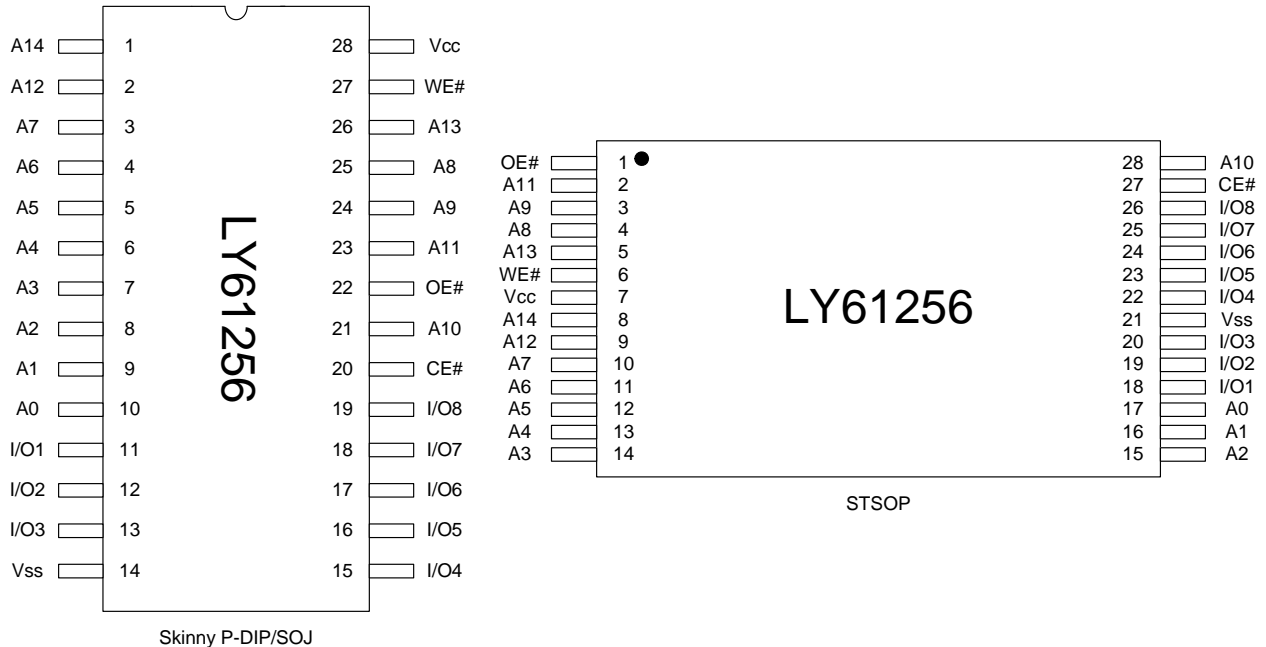

REVISION HISTORY

<u>Revision</u>	<u>Description</u>	<u>Issue Date</u>
Rev. 1.0	Initial Issue	Jul.25.2004
Rev. 1.1	Delete Icc1/ I _{SB} Spec.	Sep.21.2004
Rev. 1.2	Adding Skinny P-DIP	Aug.18.2005
Rev. 1.3	Revised STSOP Package Outline Dimension	Mar.26.2008
Rev. 1.4	Revised V _{TERM} to V _{T1} and V _{T2} Revised Test Condition of I _{SB1} /I _{DR} Added LL Spec.	Feb.2.2009
Rev. 1.5	Revised Test Condition of I _{CC} Revised FEATURES & ORDERING INFORMATION <u>Lead free and green package available to Green package available</u> Deleted T _{SOLDER} in <u>ABSOLUTE MAXIMUN RATINGS</u> Added packing type in <u>ORDERING INFORMATION</u>	Apr.17.2009

PIN CONFIGURATION

ABSOLUTE MAXIMUM RATINGS*

PARAMETER	SYMBOL	RATING	UNIT
Voltage on Vcc relative to Vss	V _{T1}	-0.5 to 6.5	V
Voltage on any other pin relative to Vss	V _{T2}	-0.5 to Vcc+0.5	V
Operating Temperature	T _A	0 to 70(C grade)	°C
		-20 to 80(E grade)	
		-40 to 85(I grade)	
Storage Temperature	T _{STG}	-65 to 150	°C
Power Dissipation	P _D	1	W
DC Output Current	I _{OUT}	50	mA

*Stresses greater than those listed under "Absolute Maximum Ratings" may cause permanent damage to the device. This is a stress rating only and functional operation of the device or any other conditions above those indicated in the operational sections of this specification is not implied. Exposure to the absolute maximum rating conditions for extended period may affect device reliability.

TRUTH TABLE

MODE	CE#	OE#	WE#	I/O OPERATION	SUPPLY CURRENT
Standby	H	X	X	High-Z	I _{SB1}
Output Disable	L	H	H	High-Z	I _{CC}
Read	L	L	H	D _{OUT}	I _{CC}
Write	L	X	L	D _{IN}	I _{CC}

Note: H = V_{IH}, L = V_{IL}, X = Don't care.



DC ELECTRICAL CHARACTERISTICS

PARAMETER	SYMBOL	TEST CONDITION	MIN.	TYP. ⁴	MAX.	UNIT	
Supply Voltage	V _{CC}		4.5	5.0	5.5	V	
Input High Voltage	V _{IH} ¹		2.4	-	V _{CC} +0.5	V	
Input Low Voltage	V _{IL} ²		-0.5	-	0.8	V	
Input Leakage Current	I _{LI}	V _{CC} ≥ V _{IN} ≥ V _{SS}	-1	-	1	μA	
Output Leakage Current	I _{LO}	V _{CC} ≥ V _{OUT} ≥ V _{SS} , Output Disabled	-1	-	1	μA	
Output High Voltage	V _{OH}	I _{OH} = -4mA	2.4	-	-	V	
Output Low Voltage	V _{OL}	I _{OL} = 8mA	-	-	0.4	V	
Average Operating Power supply Current	I _{CC}	Cycle time = Min. CE# = V _{IL} , I _{I/O} = 0mA Others at V _{IL} or V _{IH}	-8	-	110	190	mA
			-10	-	100	180	mA
			-12	-	90	160	mA
			-15	-	80	140	mA
Standby Power Supply Current	I _{SB1}	CE# ≥ V _{CC} - 0.2V,	Normal	-	1	5	mA
		CE# ≥ V _{CC} - 0.2V, Others at 0.2V or V _{CC} -0.2V	LL	-	2	50	μA

Notes:

- V_{IH}(max) = V_{CC} + 3.0V for pulse width less than 10ns.
- V_{IL}(min) = V_{SS} - 3.0V for pulse width less than 10ns.
- Over/Undershoot specifications are characterized, not 100% tested.
- Typical values are included for reference only and are not guaranteed or tested.
Typical values are measured at V_{CC} = V_{CC}(TYP.) and T_A = 25°C

CAPACITANCE (T_A = 25°C, f = 1.0MHz)

PARAMETER	SYMBOL	MIN.	MAX	UNIT
Input Capacitance	C _{IN}	-	6	pF
Input/Output Capacitance	C _{I/O}	-	8	pF

Note : These parameters are guaranteed by device characterization, but not production tested.

AC TEST CONDITIONS

Input Pulse Levels	0.2V to V _{CC} - 0.2V
Input Rise and Fall Times	3ns
Input and Output Timing Reference Levels	1.5V
Output Load	C _L = 30pF + 1TTL, I _{OH} /I _{OL} = -4mA/8mA



AC ELECTRICAL CHARACTERISTICS

(1) READ CYCLE

PARAMETER	SYM.	LY61256-8		LY61256-10		LY61256-12		LY61256-15		UNIT
		MIN.	MAX.	MIN.	MAX.	MIN.	MAX.	MIN.	MAX.	
Read Cycle Time	t _{RC}	8	-	10	-	12	-	15	-	ns
Address Access Time	t _{AA}	-	8	-	10	-	12	-	15	ns
Chip Enable Access Time	t _{ACE}	-	8	-	10	-	12	-	15	ns
Output Enable Access Time	t _{OE}	-	4	-	5	-	6	-	7	ns
Chip Enable to Output in Low-Z	t _{CLZ} *	2	-	2	-	3	-	4	-	ns
Output Enable to Output in Low-Z	t _{OLZ} *	0	-	0	-	0	-	0	-	ns
Chip Disable to Output in High-Z	t _{CHZ} *	-	4	-	5	-	6	-	7	ns
Output Disable to Output in High-Z	t _{OHZ} *	-	4	-	5	-	6	-	7	ns
Output Hold from Address Change	t _{OH}	3	-	3	-	3	-	3	-	ns

(2) WRITE CYCLE

PARAMETER	SYM.	LY61256-8		LY61256-10		LY61256-12		LY61256-15		UNIT
		MIN.	MAX.	MIN.	MAX.	MIN.	MAX.	MIN.	MAX.	
Write Cycle Time	t _{WC}	8	-	10	-	12	-	15	-	ns
Address Valid to End of Write	t _{AW}	6.5	-	8	-	10	-	12	-	ns
Chip Enable to End of Write	t _{CW}	6.5	-	8	-	10	-	12	-	ns
Address Set-up Time	t _{AS}	0	-	0	-	0	-	0	-	ns
Write Pulse Width	t _{WP}	6.5	-	8	-	9	-	10	-	ns
Write Recovery Time	t _{WR}	0	-	0	-	0	-	0	-	ns
Data to Write Time Overlap	t _{DW}	5	-	6	-	7	-	8	-	ns
Data Hold from End of Write Time	t _{DH}	0	-	0	-	0	-	0	-	ns
Output Active from End of Write	t _{OW} *	1.5	-	2	-	3	-	4	-	ns
Write to Output in High-Z	t _{WHZ} *	-	5	-	6	-	7	-	8	ns

*These parameters are guaranteed by device characterization, but not production tested.

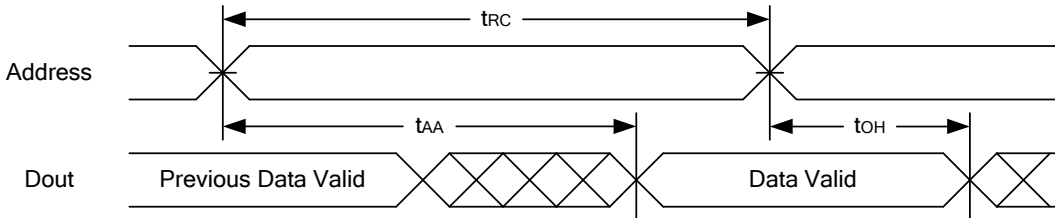
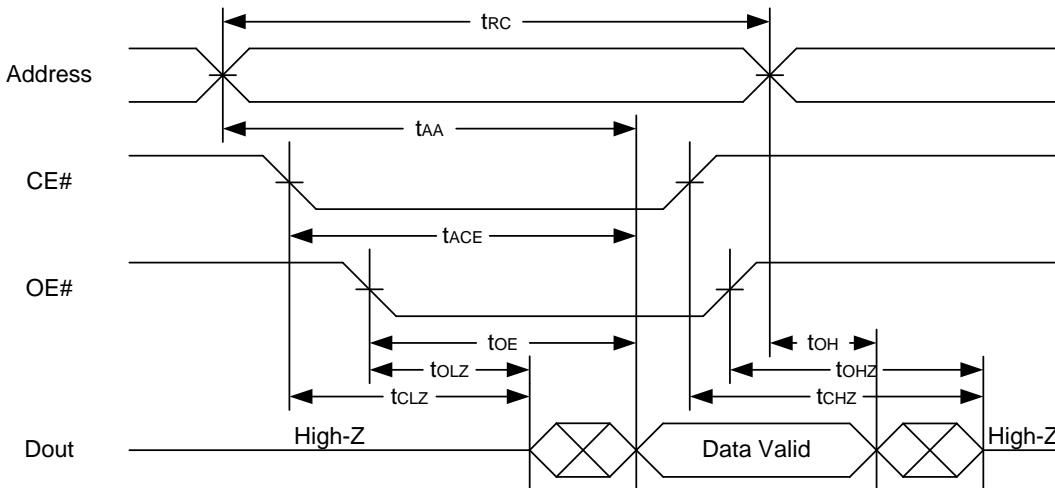
TIMING WAVEFORMS
READ CYCLE 1 (Address Controlled) (1,2)

READ CYCLE 2 (CE# and OE# Controlled) (1,3,4,5)

Notes :

1. WE# is high for read cycle.
2. Device is continuously selected OE# = low, CE# = low.
3. Address must be valid prior to or coincident with CE# = low; otherwise t_{AA} is the limiting parameter.
4. t_{CLZ} , t_{OLZ} , t_{CHZ} and t_{OHZ} are specified with $C_L = 5\text{pF}$. Transition is measured $\pm 500\text{mV}$ from steady state.
5. At any given temperature and voltage condition, t_{CHZ} is less than t_{CLZ} , t_{OHZ} is less than t_{OLZ} .

DATA RETENTION CHARACTERISTICS

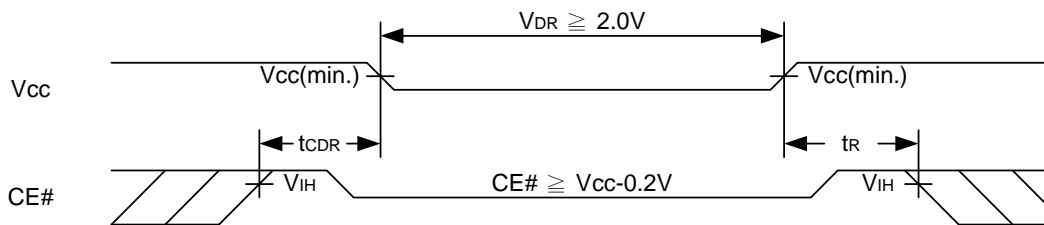
PARAMETER	SYMBOL	TEST CONDITION	MIN.	TYP.	MAX.	UNIT	
VCC for Data Retention	V _{DR}	CE# \geq V _{CC} - 0.2V	2.0	-	5.5	V	
Data Retention Current	I _{DR}	V _{CC} = 2.0V CE# \geq V _{CC} - 0.2V	Normal	-	0.6	3	mA
		V _{CC} = 2.0V CE# \geq V _{CC} - 0.2V Others at 0.2V or V _{CC} -0.2V	LL	-	0.5	20	μ A
Chip Disable to Data Retention Time	t _{CDR}	See Data Retention Waveforms (below)	0	-	-	ns	
Recovery Time	t _R		t _{RC} *	-	-	ns	

 t_{RC}* = Read Cycle Time

DATA RETENTION WAVEFORM

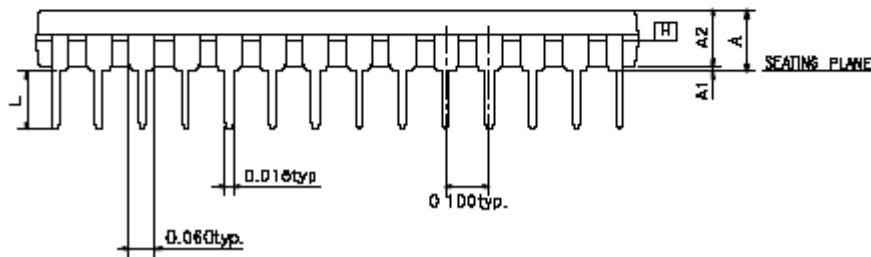
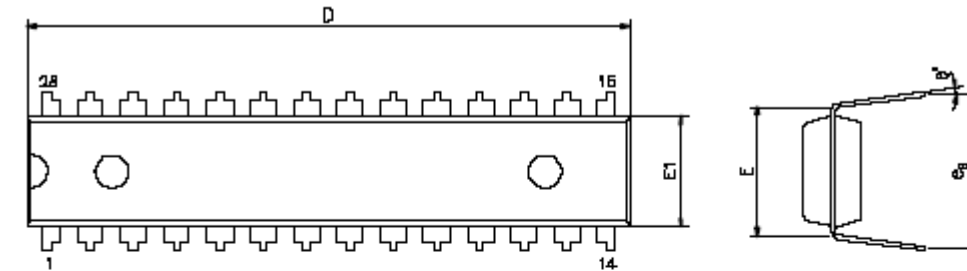
PACKAGE OUTLINE DIMENSION
28 pin 300 mil PDIP Package Outline Dimension

SYMBOLS	MIN.	NOR.	MAX.
A	—	—	0.210
A1	0.015	—	—
A2	0.125	0.130	0.135
D	1.385	1.390	1.400
E	0.310 BSC		
E1	0.283	0.288	0.293
L	0.115	0.130	0.150
eB	0.330	0.350	0.370
θ°	0	7	15

UNIT : INCH

NOTE:

1. JEDEC OUTLINE : MS-D15 AH

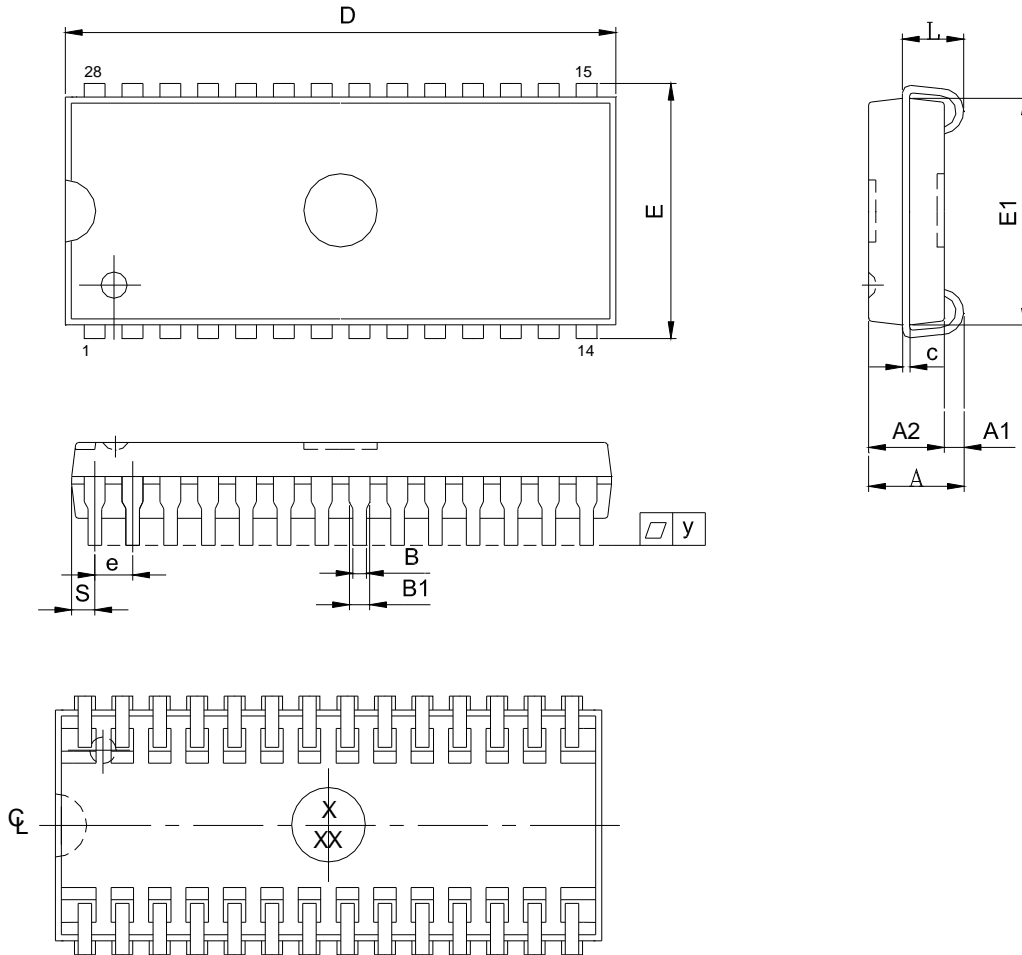
28-pin 300 mil SOJ Package Outline Dimension

SYM.	UNIT	INCH(REF)	MM(BASE)
A		0.140 (MAX)	3.556 (MAX)
A1		0.026 (MIN)	0.660 (MIN)
A2		0.100±0.005	2.540±0.127
B		0.018±0.003	0.457±0.076
B1		0.028 ±0.003	0.711±0.076
c		0.010±0.003	0.254±0.076
D		0.710±0.010	18.03±0.254
E		0.337±0.010	8.560±0.254
E1		0.300±0.005	7.620±0.127
e		0.050±0.003	1.270±0.076
L		0.087±0.010	2.210±0.254
S		0.030±0.004	0.762±0.102
Y		0.003 (MAX)	0.076 (MAX)

Note : 1.S/E/D dimension is not including mold flash.

2.The end flash in package lengthwise is not more than 10 mils each side.

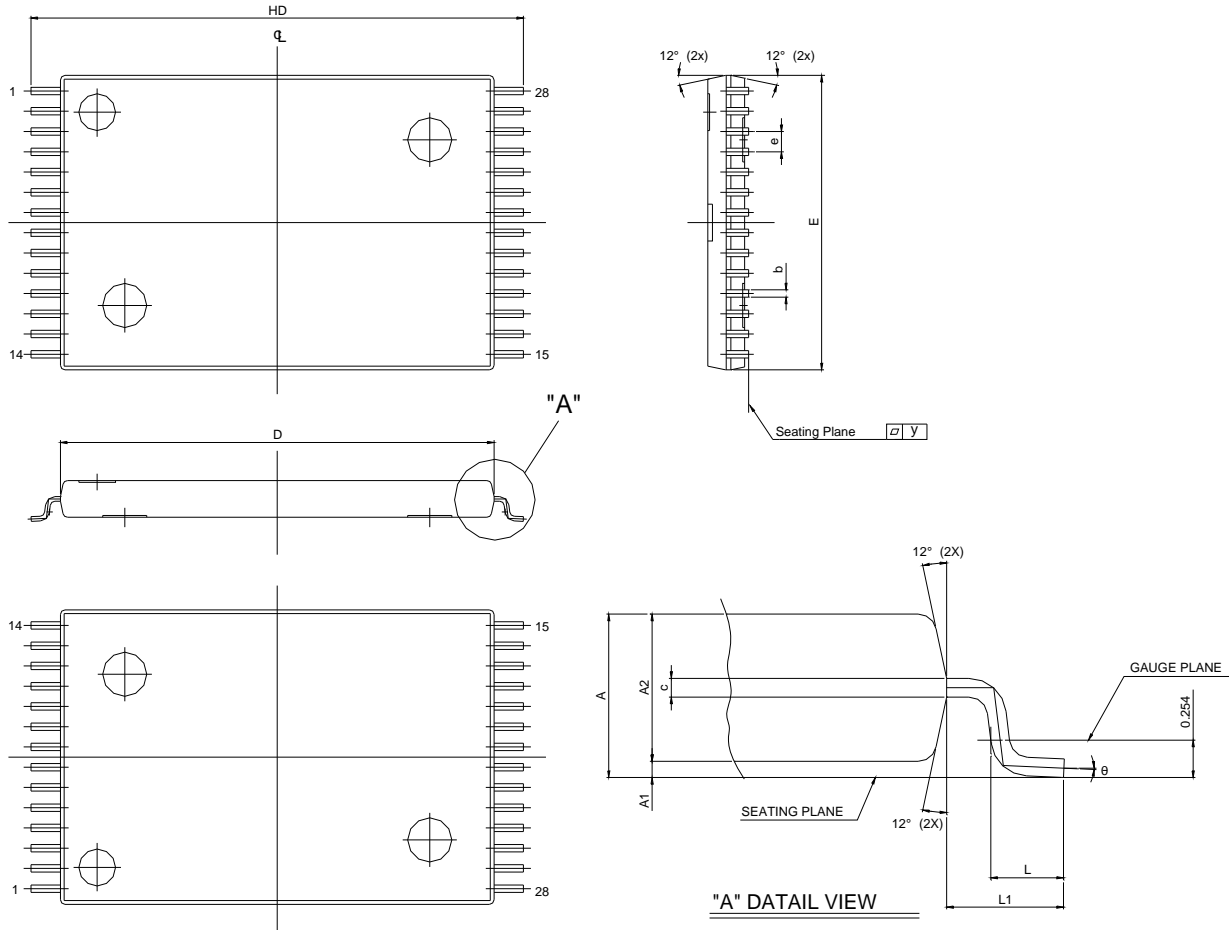
28 pin 8x13.4mm STSOP Package Outline Dimension

SYMBOLS	DIMENSIONS IN MILLIMETERS			DIMENSIONS IN INCHES		
	MIN	NOM	MAX	MIN	NOM	MAX
A	1.00	1.10	1.20	0.040	0.043	0.047
A1	0.05	-	0.15	0.002	-	0.006
A2	0.91	1.00	1.05	0.036	0.039	0.041
b	0.17	0.22	0.27	0.007	0.009	0.011
c	0.10	0.15	0.20	0.004	0.006	0.008
HD	13.20	13.40	13.60	0.520	0.528	0.535
D	11.70	11.80	11.90	0.461	0.465	0.469
E	7.90	8.00	8.10	0.311	0.315	0.319
e	-	0.55	-	-	0.0216	-
L	0.30	0.50	0.70	0.012	0.020	0.028
L1	0.675	-	-	0.027	-	-
Y	0.00	-	0.076	0.000	-	0.003
θ	0°	3°	5°	0°	3°	5°



ORDERING INFORMATION

LY61256 U V - WW XX Y Z

Z : Packing Type
Blank : Tube or Tray
T : Tape Reel

Y : Temperature Range
Blank : (Commercial) 0°C ~ 70°C
E : (Extended) -20°C ~ +80°C
I : (Industrial) -40°C ~ +85°C

XX : Power Type
LL : Ultra Low Power

WW : Access Time(Speed)

V : Lead Information
L : Green Package

U : Package Type
J : 28-pin 300 mil SOJ
D : 28-pin 330 mil P-DIP
R : 28-pin 8 mm x 13.4 mm STSOP

THIS PAGE IS LEFT BLANK INTENTIONALLY.