

Micro-D Hermetic Connectors Rear Panel Mount With O-Ring 177-705H and 177-706H

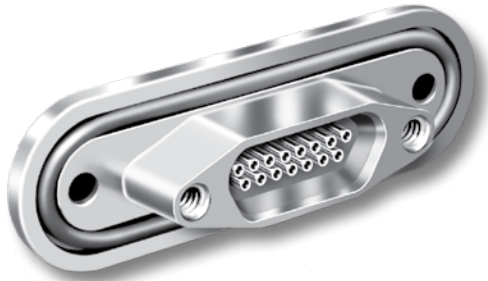

Micro-D
Hermetic



Fluorosilicone O-Ring eliminates the cost of soldering or welding the connector to a bulkhead.

Kovar® Shells and Contacts comply with applicable MIL-DTL-83513 requirements and are 100% intermateable with standard connectors.

Solder Cup, PC Tail or Pre-Wired and Fully Potted
Suitable for #26 gage wire or smaller, solder cup versions feature gold-plated contacts. Choose PC tails for attachment to flex circuits or rigid boards. Solder cup versions are also available pre-wired and potted.

HOW TO ORDER SOLDER CUP AND PC TAIL CONNECTORS

Series	Layout Number of Contacts	Contact Type	Termination Type	Mounting Threads
177-705H Micro-D Hermetic Socket Receptacle, Rear Panel Mount with O-Ring, Solder Cup or PC Tail	9 15 21 25 31 37	S – Socket	SS – Solder Cup SP – PC Tail	U – #4 - 40 UNC M – M3 Metric
Sample Part Number				
177-705H	15	S	SP	U

G

HOW TO ORDER PRE-WIRED CONNECTORS

Series	Layout	Contact Type	Wire Gage (AWG)	Wire Type	Wire Color	Wire Length Inches
177-706H	9 15 21 25 31 37	S – Socket	6 – #26 8 – #28 0 – #30	K – M22759/11 600 Vrms Teflon (TFE) (Not Available in #30 AWG) J – M22759/33 600 Vrms Modified Cross-Linked Tefzel (ETFE)	1 – White 2 – Yellow 5 – Color-Coded Stripes Per MIL-STD-681 (#26 gage only) 7 – Ten Color Repeat	18 Wire Length In Inches. "18" Specifies 18 Inches.
Sample Part Number						
177-706H	25	S	6	K	1	– 18

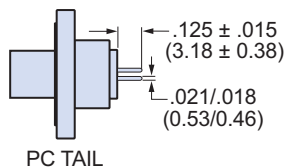
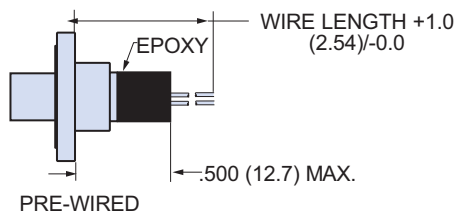
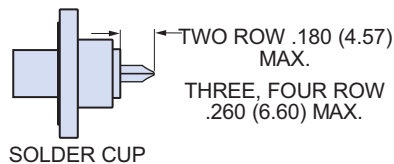
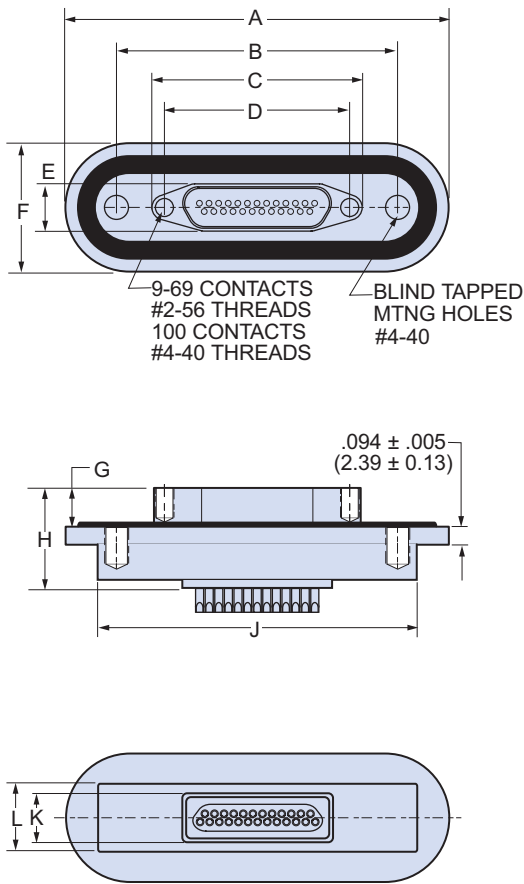

DIMENSIONS

Layout	A Max.		B		C MAX.		D		E MAX.		F Max.		G		H Max.		J		K		L Max.	
	In.	mm.	In. ±.005	mm. ±0.13	In.	mm.	In. ±.003	mm. ±0.08	In.	mm.	In.	mm.	In. ±.004	mm. ±0.10	In.	mm.	In.	mm.	In. ±.004	mm. ±0.10	In.	mm.
9S	1.488	37.80	1.011	25.67	.728	18.49	.565	14.35	.250	6.35	.675	17.14	.195	4.95	.526	13.36	1.254	31.85	.254	6.45	.358	9.09
15S	1.638	41.61	1.161	29.48	.878	22.30	.715	18.16	.250	6.35	.675	17.14	.195	4.95	.526	13.36	1.414	36.91	.254	6.45	.358	9.09
21S	1.788	45.42	1.311	33.29	1.028	32.51	.865	21.97	.250	6.35	.675	17.14	.195	4.95	.526	13.36	1.564	39.72	.254	6.45	.358	9.09
25S	1.888	47.96	1.411	35.83	1.128	28.65	.965	24.51	.250	6.35	.675	17.14	.195	4.95	.526	13.36	1.664	42.26	.254	6.45	.358	9.09
31S	2.038	51.76	1.561	39.64	1.278	32.46	1.115	28.32	.250	6.35	.675	17.14	.195	4.95	.526	13.36	1.814	46.07	.254	6.45	.358	9.09
37S	2.188	55.57	1.711	43.45	1.428	36.27	1.265	32.13	.250	6.35	.675	17.14	.195	4.95	.526	13.36	1.984	50.39	.254	6.45	.358	9.09

Micro-D Hermetic Connectors Rear Panel Mount With O-Ring 177-705H and 177-706H



PANEL CUTOUT DIMENSIONS FOR 177-705 AND 177-706

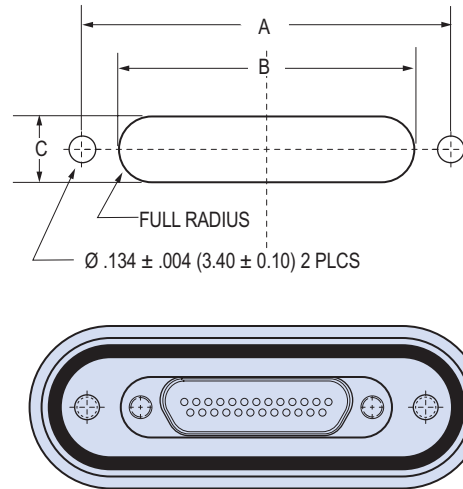

Layout	A		B		C	
	In. $\pm .003$	mm. ± 0.08	In. $\pm .005$	mm. ± 0.13	In. $+ .005/-0.0$	mm. $+0.13/-0.0$
9	1.011	25.69	.731	18.56	.252	6.40
15	1.161	29.50	.881	22.37	.252	6.40
21	1.311	33.31	1.031	26.18	.252	6.40
25	1.411	35.85	1.131	28.72	.252	6.40
31	1.561	39.66	1.281	32.53	.252	6.40
37	1.711	43.47	1.431	36.34	.252	6.40

G