

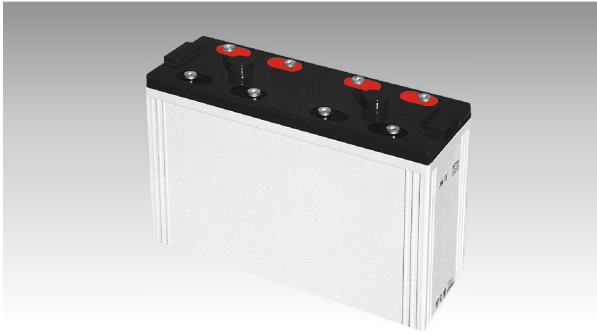

# SW28000E(2V800AH)

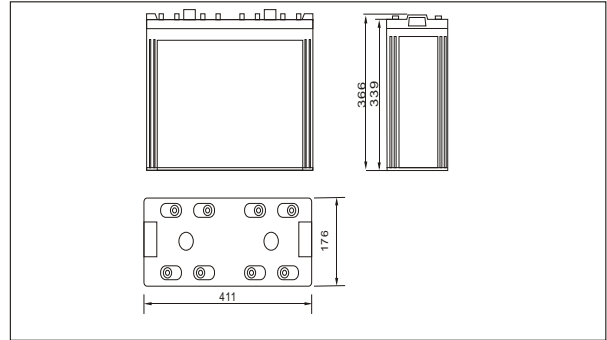

## ● Outer dimensions (mm)



## ● Specifications

Nominal Voltage		2 V
Rated capacity (10 hour rate)		800 Ah
Dimensions	Total Height	366 mm (14.4 inches)
	Height	339 mm (13.3 inches)
	Length	411 mm (16.2 inches)
	Width	176 mm (6.93 inches)
Weight Approx		53 Kg (116.6 lbs)

## ● Terminal Type (mm)

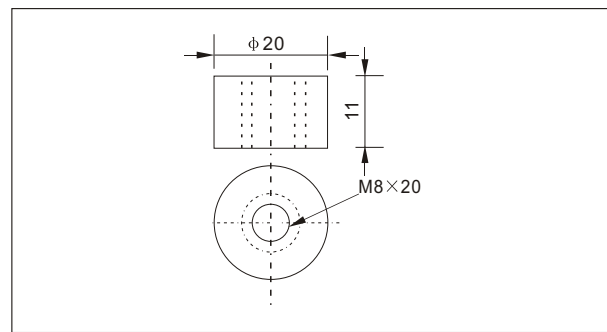

## ● Characteristics

Capacity 25°C(77°F)	10 hour rate(120 A)	800 AH
	5 hour rate(128A)	640AH
	1 hour rate(440 A)	440 AH
	1.5 hour discharge to 1.75 V	320 A
Internal Resistance	Full charged Battery at 25°C(77°F)	1.4 mΩ
Capacity affected by Temperature (10hour rate)	40°C(104°F)	102%
	25°C(77°F)	100%
	0°C(32°F)	85%
	-15°C(5°F)	65%
Self-Discharge at 25°C(77°F)	Capacity after 3 month storage	91%
	Capacity after 6 month storage	82%
	Capacity after 12 month storage	64%
Terminal	T20	
Charge (constant Voltage)	Cycle	Initial Charging Current less than 200 A Voltage 2.35-2.40V
	Float	Voltage 2.25-2.30V

## ● Discharge Curves 25°C(77°F)

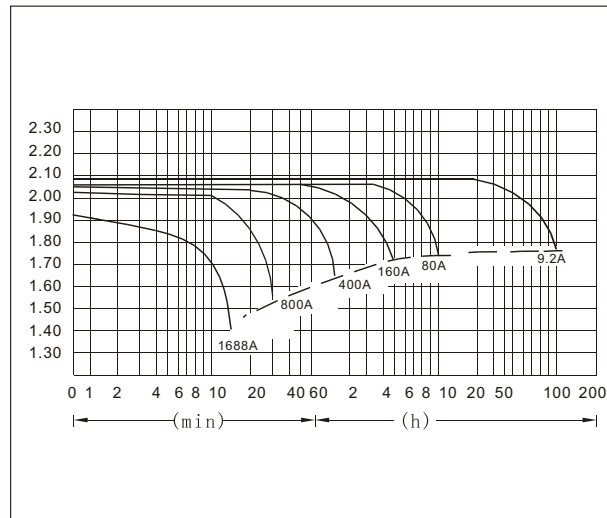

**Constant Current(Amp) and Constant Power(Watt) Discharge Table at 25°C(77°F)**

Time		10min	30min	1h	3h	4h	5h	8h	10h	20h	50h	100h
1.60V	A	1688	912	480	205.6	160.0	132.0	93.0	84.0	45.36	18.9	9.7
	W	3124	1628	926	397	309	255	180	162	87.5	37.5	19.2
1.70V	A	1640	888	451.2	200.0	156.0	129.6	91.0	81.9	44.24	18.2	9.4
	W	3005	1613	871	386	301	250	176	158	85.4	36.1	18.7
1.75V	A	1567	845	437	195.2	153.6	128.0	90.4	80.0	43.68	17.9	9.2
	W	2912	1523	843	377	296	247	174	156	84.3	35.6	18.3
1.80V	A	1464	817	422	190.4	151.2	124.8	88.0	78.0	43.20	17.6	9.1
	W	2799	1465	806	369	290	242	171	155	83.8	34.9	18.1
1.85V	A	1344	752	398	184.0	146.7	121.6	85.6	76.00	41.04	17.3	8.8
	W	2751	1453	785	365	289	241	170	151	81.4	34.3	17.5