

Photodiode in Plastic Surface Mount Package

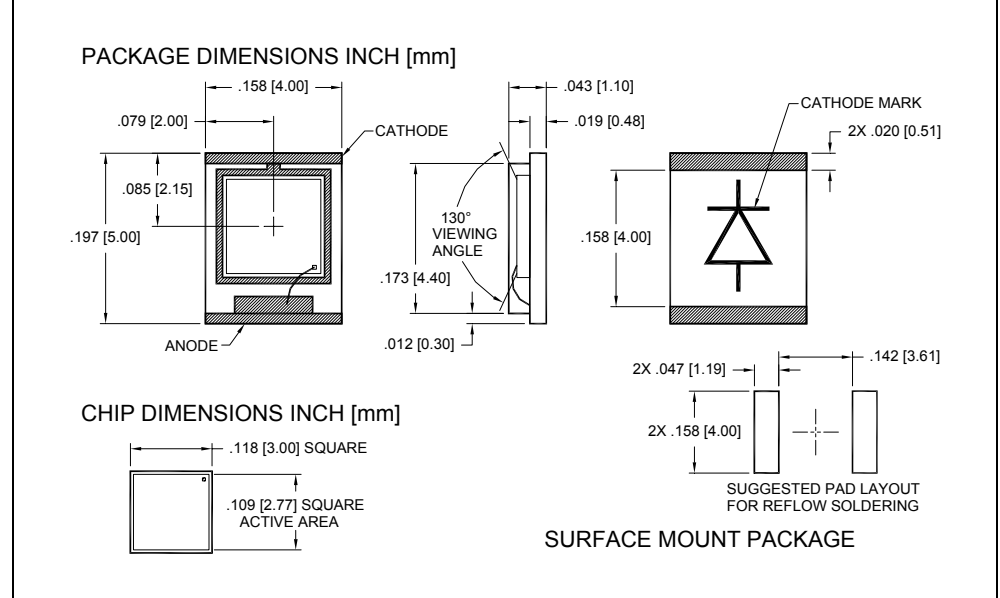
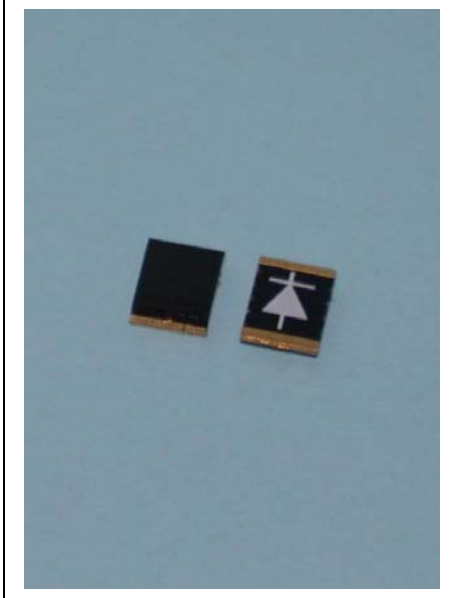

FEATURES

- Surface mount
- Photoconductive
- Low cost
- High speed

DESCRIPTION

The **PDI-C172SMF** is a blue enhanced PIN silicon photodiode ideal for high speed photoconductive or photovoltaic applications packaged in a black plastic surface mount package.

APPLICATIONS

- Photointerrupters
- Oximeter sensors
- Barcode
- Glucometers

ABSOLUTE MAXIMUM RATING (TA)= 23°C UNLESS OTHERWISE NOTED

SYMBOL	PARAMETER	MIN	MAX	UNITS
V _{BR}	Reverse Voltage		60	V
T _{STG}	Storage Temperature	-55	+100	°C
T _O	Operating Temperature	-40	+80	°C
T _S	Soldering Temperature*		+260	°C

* 1/16 inch from case for 3 seconds max.

SPECTRAL RESPONSE

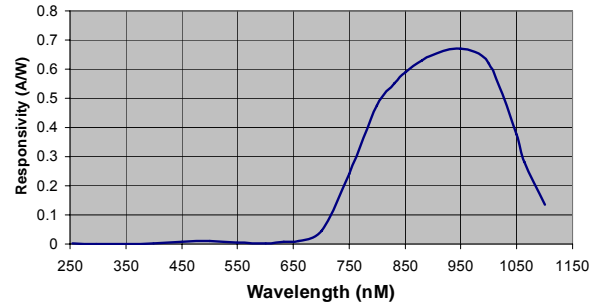

ELECTRO-OPTICAL CHARACTERISTICS RATING (TA)= 23°C UNLESS OTHERWISE NOTED

SYMBOL	CHARACTERISTIC	TEST CONDITIONS	MIN	TYP	MAX	UNITS
I _{SC}	Short Circuit Current	H = 100 fc, 2850 K		90		μA
I _D	Dark Current	V _R = 10 V		4	30	nA
R _{SH}	Shunt Resistance	V _R = 10 mV		400		MΩ
C _J	Junction Capacitance	V _R = 10 V, f = 1 MHz		15		pF
λ range	Spectral Application Range	Spot Scan	840		1050	nm
V _{BR}	Breakdown Voltage	I = 10 μA	60			V
NEP	Noise Equivalent Power	V _R = 10V @ λ = Peak		4x10 ⁻¹⁴		W/√Hz
t _r	Response Time	RL = 1KΩ, V _R = 10 V		20		nS

**Response time of 10% to 90% is specified at 660nm wavelength light.

Information in this technical datasheet is believed to be correct and reliable. However, no responsibility is assumed for possible inaccuracies or omission. Specifications are subject to change without notice.